

D**+GF+****JRG****Montageanleitung****Befestigung vorne**

Bei dieser Montageart wird das UP-Ventil über das Schutzrohr mit der patentierten Klemmhalterung gehalten.

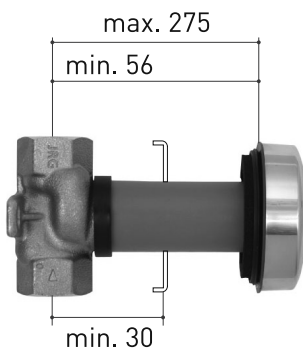

Das bauseitig gelieferte Befestigungsblech von **min. 2 bis max. 3 mm** dicke muss mit einer Bohrung von $\varnothing 38$ mm versehen sein.

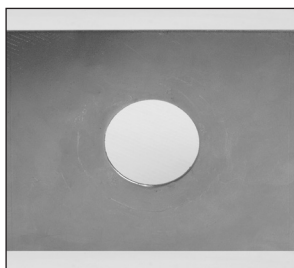
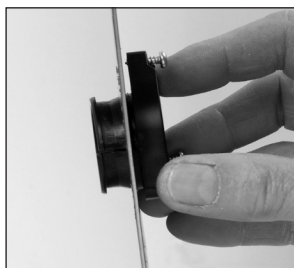

Geschlitzter vormontierter Klemmring zusammendrücken, mit dem Kragen in die Bohrung einführen und einklinken.

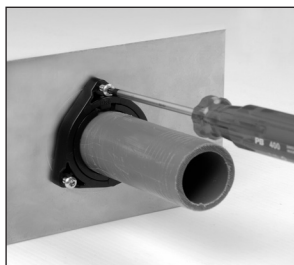

UP-Ventil von der Rückseite durch die Klemmhalterung einführen. Auf das gewünschte Mass ausrichten und die drei Blechschrauben gleichmässig bis zum Anschlag anziehen (Schraubenkopf Torx 15).

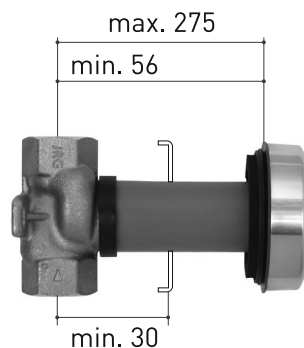
F**+GF+****JRG****Instruction de montage****Fixation à l'avant**

Pour ce type de montage, le robinet d'arrêt à encastrer est fixé sur le support de serrage.

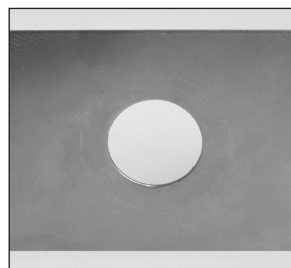

La tôle de fixation d'une épaisseur **minimale de 2-maximale de 3 mm** livrée sur le chantier doit être pourvue d'un percement de $\varnothing 38$ mm.

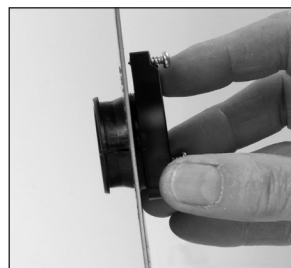

Compresser la bague de serrage entaillée et pré-montée, l'introduire et la clipser dans le percement avec le col vers l'arrière.

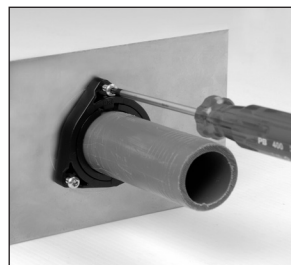

Introduire le robinet d'arrêt à encastrer depuis l'arrière dans la support de serrage. Ajuster à la cote désirée et visser régulièrement les trois vis de la tôle jusqu'en butée (tournevis Torx 15).

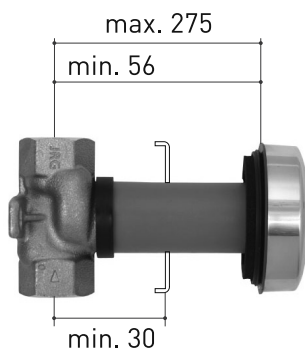
I**+GF+****JRG****Istruzioni di montaggio****Fissaggio anteriore**

Con questo tipo di montaggio, la valvola incassata viene fissata tramite il fermo.

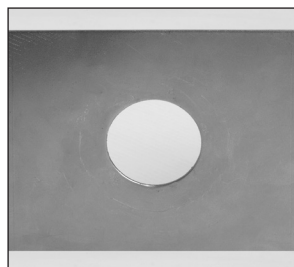

La lamiera di fissaggio fornita in situ di **minimo 2 mm e massimo 3 mm** di spessore deve essere dotata di un foro di diametro di 38 mm.

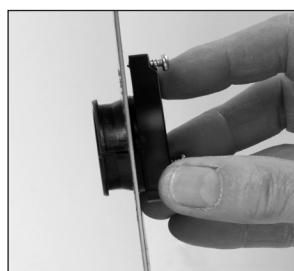

Comprimere assieme l'anello di fissaggio fessurato premon-tato. Inserirlo nel foro con il collarino rivolto all'indietro e fissarlo.

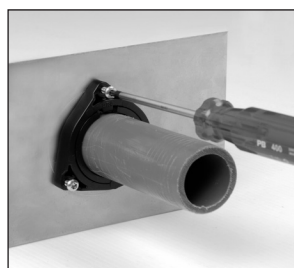

Inserire la valvola incassata dalla parte posteriore tramite il fermo. Allineare alla dimen-sione desiderata e serrare le tre viti della lamiera unifor-memente fino alla battuta (cacciavite Torx 15).

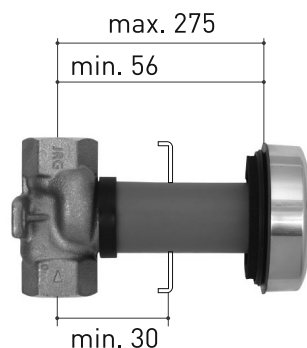
E**+GF+****JRG****Installation****Front mounting**

With this mounting method the UP valve is fixed using a clamp.

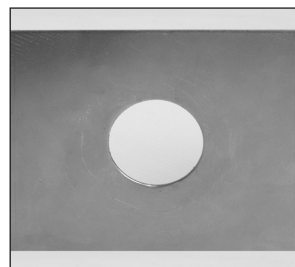

The mounting panel provided by the client with a thickness of **minimum 2–maximum 3 mm** must come with a borehole of 38 mm diameter.

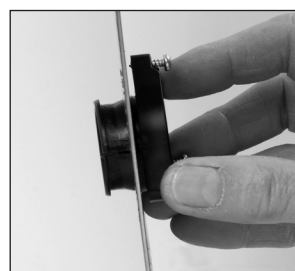

Squeeze the slotted pre-assembled clamping ring; insert it with the collar first through the borehole until it clips on the mounting panel.

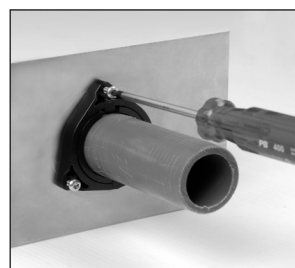

Insert the UP valve through the clamp from the back. Adjust it according to the desired length and screw in the three sheet-metal screws fully (screwdriver torx 15).