

JRG

+GF+

Montageanleitung

Notice de montage

Istruzioni per il montaggio

Installation instructions

JRGURED Combi

Hauswasserstation

D 2- 5

Station de réduction avec filtre

F 7-10

Gruppo acqua combinato

I 11-14

Domestic water station

E 15-18

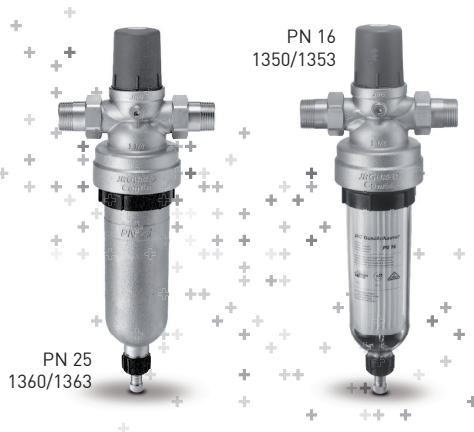



60 mm

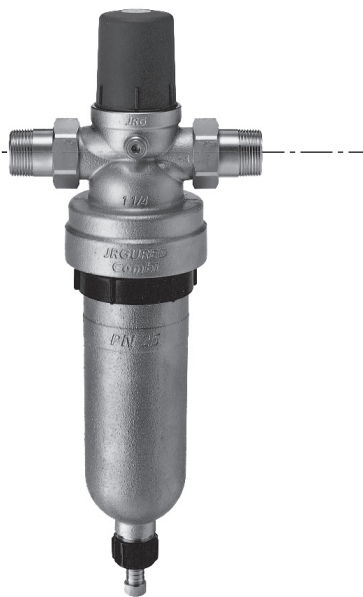

60 mm



Montageanleitung

Bitte lesen Sie die vorliegende Montageanleitung aufmerksam durch. Die eingesetzten Symbole bedeuten:



Warnung

Dieses Symbol weist auf eine Information hin, deren Nichtbeachtung zu umfangreichen Sachschäden führen kann. Die Sicherheitshinweise sind zu beachten.



Hinweis

Dieses Symbol weist auf eine Information hin, die wichtige Angaben hinsichtlich der Verwendung enthält. Das Nichtbefolgen kann zu Störungen führen.

Allgemeines

Die Hauswasserstation JRGURED Combi ist eine kompakte Armaturenkombination für Wasserinstallationen*, bestehend aus Feinfilter und Druckreduzierventil.

* Andere Anwendungen auf Anfrage.

Der vor dem Druckreduzierventil eingesetzte Filtereinsatz dient lediglich dem Zurückhalten von eingespülten Schwebestoffen. Er ersetzt in keiner Weise eine gewünschte oder notwendige Wasseraufbereitung (Enthärtung, Entkeimung, etc.)!

Einsatzbereich

Die Hauswasserstation JRGURED Combi ist für folgende Einsatzbereiche zugelassen:

JRG Code 1350/1353 PN 16

Wassertemperatur:	max. 30°C
Primärdruck:	max. 16 bar
Sekundärdruck einstellbar:	2–6 bar*

JRG Code 1360/1363 PN 25

Wassertemperatur:	max. 30°C**
Primärdruck:	max. 25 bar
Sekundärdruck einstellbar:	2–6 bar*

* Andere Einstelldrücke auf Anfrage

** Mit Filtereinsatz JRG Code 1839 bis 70°C

Kennzeichnung

- 1, 1¼, 1½, 2 (GN/Ventilgrösse)
- JRGURED Combi (Name der Armatur)
- JRG (Herstellerzeichen)
- Durchflusspeile



Hinweis

AFM 34 Dichtungen dürfen **nicht** geölt oder gefettet werden.

Werkseinstellung

Die Hauswasserstation JRGURED Combi ist werkseitig auf einen Sekundärdruck von 4 bar eingestellt.

Installationsvorschriften



Beim Einbau der JRG Hauswasserstation JRGURED Combi sind die örtlich geltenden Vorschriften/ Normen einzuhalten.

Montage



Die Hauswasserstation JRGURED Combi darf nur mit geeignetem Werkzeug montiert werden.

Einbaulage



Die Hauswasserstation JRGURED Combi ist an einer gut zugänglichen Stelle, spannungsfrei in eine horizontale Leitung einzubauen.

Für die Filterwartung ist unter dem Entleerventil ein Mindestabstand von 60 mm einzuhalten. Wird für die Entleerung ein Schlauch eingesetzt, ist dieses Mass entsprechend zu berücksichtigen.



Hauswasserstationen mit Klarsichtfilterbecher sind so zu montieren, dass sie vor intensiver UV-Strahlung geschützt sind. Bei Installationen in aggressiver Umgebung und/oder in Räumen mit unkontrollierbaren Umwelteinflüssen (wie Lösungs- oder Reinigungsmitteldämpfen etc.) muss der Klarsichtfilterbecher entsprechend geschützt oder gegen einen Rotgussfilterbecher ersetzt werden. Im Zweifelsfall beraten wir Sie gerne.

Inbetriebnahme



Vor der Inbetriebnahme der Hauswasserstation JRGURED Combi ist die Zuleitung gründlich zu spülen. Für die Inbetriebnahme ist die separate Bedienungs- und Wartungsanleitung zu beachten.



An der Hauswasserstation JRGURED Combi dürfen **keine** Reparaturen vorgenommen werden.

Umstellung des Druckreduzierventils



Ein Umstellen der Werkseinstellung erfolgt ausschliesslich auf Verantwortung des Ausführenden. Für das Umstellen beachten Sie bitte die separate Bedienungs- und Wartungsanleitung.

Wartung



Für die Wartung des Feinfilters ist die separate Bedienungs- und Wartungsanleitung zu beachten. Diese ist bei der Übergabe der Anlage dem Hauseigentümer abzugeben.



JRGURED Combi

Station de réduction avec filtre F 7-10

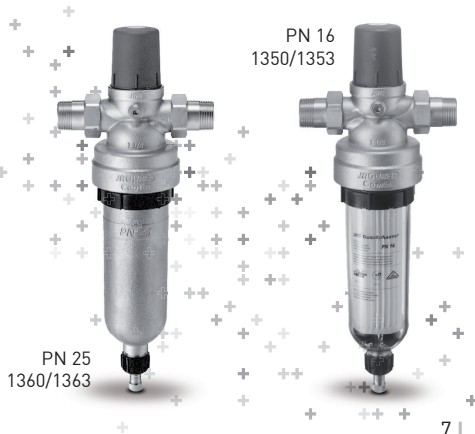

Notice de montage

Veuillez lire attentivement la présente notice de montage. Voici la signification des symboles utilisés:



Avertissement

Ce symbole rappelle une information dont le non-respect peut entraîner des dommages considérables. Suivre les consignes de sécurité.



Remarque

Ce symbole signale une information qui comprend des indications importantes portant sur l'utilisation. Le non-respect peut se traduire par des pannes.

Généralités

La station JRGURED Combi constitue une combinaison compacte de robinetterie, destinée aux installations de distribution d'eau*. Elle se compose d'un filtre fin et d'un réducteur de pression.

* Autres applications sur demande.

Le cartouche filtrant monté dans la station JRGURED Combi sert uniquement à retenir les particules en suspension. Il ne remplace en aucun cas une installation souhaitée ou indispensable de traitement de l'eau (deminéralisation, décontamination, etc.)!

Domaine d'utilisation

La station JRGURED Combi est homologuée pour les domaines d'utilisation suivants:

JRG Code 1350/1353 PN 16

Température de l'eau:	max. 30°C
Pression primaire:	max. 16 bars
Pression secondaire (ajustable):	2-6 bars*

JRG Code 1360/1363 PN 25

Température de l'eau:	max. 30°C**
Pression primaire:	max. 25 bars
Pression secondaire (ajustable):	2-6 bars*

* Autres valeurs de consigne sur demande

** Avec cartouche filtrante JRG Code 1839 jusqu'à 70°C

Repérage

- 1, 1¼, 1½, 2 (GN/grandeur de vanne)
- JRGURED Combi (nom de la robinetterie)
- JRG (nom du fabricant)
- Flèches de débit



Remarque

Ne jamais graisser **ni** huiler les joints plats en fibrine **AFM 34**.

Pression de consigne

Départ usines, la pression secondaire des stations JRGURED Combi est ajustée sur 4 bars.

Prescription de pose



Lors du montage de la station JRGURED Combi, les prescriptions ainsi que les normes de montage locale sont à respecter.

Montage



La station JRGURED Combi ne doit être montée qu'avec l'outillage approprié.

Position de montage



La station JRGURED Combi ne doit être montée que dans des conduites horizontales, en un endroit facilement accessible.

Pour assurer l'entretien du filtre fin, il convient de ménager une distance minimale de 60 mm sous le robinet de vidange. Lorsque la vidange s'effectue au moyen d'un tuyau, il convient d'augmenter la distance ci-dessus.



Les stations JRGURED Combi, équipées d'une cuve transparente ne doivent pas être exposées au rayonnement ultraviolet intense. Sur des installations dans un entourage agressif et/ou à des endroits avec des influences ambiantes non contrôlables (comme des vapeurs de dissolvant ou de produits de nettoyage etc.) la cuve transparente doit être protégée contre l'environnement, ou échangée contre une cuve en fonte rouge. Nous vous conseillons volontiers en cas d'incertitude.

Mise en service



Avant la mise en service de la station JRGURED Combi, il convient de rincer soigneusement la conduite.

Modification de la valeur de consigne du réducteur de pression



Une modification de la valeur réglée en usine se fait sous l'entière responsabilité de l'exécutant. Pour modifier la valeur de consigne, veuillez s.v.p. observer les indications de la notice d'utilisation et d'entretien séparée.

Entretien



L'entretien du filtre fin s'effectue en suivant les indications de la notice séparée d'utilisation et d'entretien. Cette notice sera donnée au propriétaire lors de la remise de l'installation.



Il n'est pas permis d'entreprendre des réparations aux stations JRGURED Combi.

Istruzioni per il montaggio

JRGURED Combi

Gruppo acqua combinato

| 11 - 14

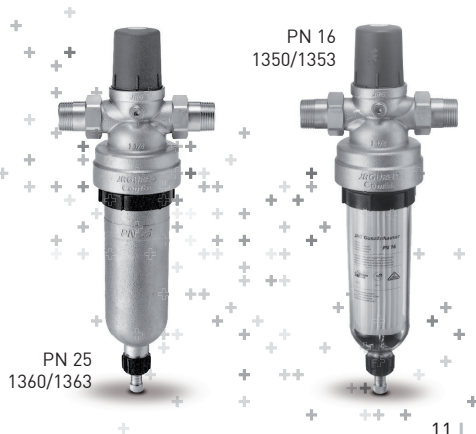

Istruzioni per il montaggio

Vogliate leggere attentamente la presente istruzione per il montaggio. I simboli seguenti significano:



Attenzione

Questo simbolo indica un'informazione che l'inosservanza della quale può portare a dei grossi danni. Queste indicazioni sulla sicurezza sono da osservare attentamente.



Avvertenza

Questo simbolo informa su importanti indicazioni concernenti l'utilizzo. L'inosservanza delle quali può causare dei guasti.

Generalità

Il gruppo acqua combinato JRGURED Combi rappresenta una combinazione compatta di rubinetteria per installazioni idrauliche*, composta da un filtro a maglia fine e da un riduttore di pressione.

* Altre applicazioni su richiesta.

Il parte filtrante impiegato nell'JRGURED Combi serve soltanto a trattenere l'affluire di sostanze galleggianti. Non rimpiazza in nessun caso un trattamento d'acqua desiderato o necessario (decalcificazione, disinfezione, ecc.).

Campo d'impiego

Il gruppo acqua combinato JRGURED Combi è omologato per i campi d'impiego seguenti:

JRG code 1350/1353 PN 16

Temperatura dell'acqua:	max. 30°C
Pressione primaria:	max. 16 bar
Pressione secondaria regolabile:	2-6 bar*

JRG code 1360/1363 PN 25

Temperatura dell'acqua:	max. 30°C**
Pressione primaria:	max. 25 bar
Pressione secondaria regolabile:	2-6 bar*

* Altre tarature su richiesta

** Con parte filtrante JRG code 1839 fino 70°C

Contrassegno

- 1, 1¼, 1½, 2 (GN/Misura della valvola)
- JRGURED Combi (nome della rubinetteria)
- JRG (marchio di fabbricazione)
- Frecche d'indicazione del flusso



Avvertenza

Le guarnizioni **AFM 34 non** devono essere oleate **né** ingrassate.

Regolazione da fabbrica

Il gruppo acqua combinato JRGURED Combi è regolato da fabbrica ad una pressione secondaria di 4 bar.

Istruzioni per il montaggio



Per il montaggio del gruppo acqua combinato JRGURED Combi, bisogna attenersi alle direttive e alle prescrizioni locali.

Montaggio



L' JRGURED Combi deve essere montato solo con attrezzi idonei.

Posizione di montaggio



Il gruppo acqua combinato deve essere montato solo su condotte orizzontali e facilmente accessibile.

Per la manutenzione del filtro bisogna osservare una distanza minima di 60 mm sotto il rubinetto di scarico. Se per lo scarico si impiega un flessibile la distanza corrispondente deve essere considerata.



I gruppi acqua combinati JRGURED Combi con tazza trasparente devono essere montati protetti dai raggi ultravioletti intensi. Installazioni in un ambiente aggressivo e/o in locali con influssi ambientali non controllabili (come solventi o vapori di detersivi ecc.) la tazza del filtro deve essere protetta o sostituita con una tazza in bronzo. In caso d'incertezza siamo a vostra disposizione per consigli in merito.

Messa in funzione



Prima della posa in opera dell' JRGURED Combi bisogna pulire le tubazioni in modo da eliminare ogni residuo.

Modifica delle regolazioni



La modifica delle regolazioni avviene sotto la responsabilità esclusiva di chi le effettua. Per procedere alle modifiche, attenersi alle istruzioni per l'uso e la manutenzione separate.

Manutenzione



Per la manutenzione del filtro a maglia fine bisogna osservare le avvertenze d'uso e di manutenzione specifiche. Queste devono essere recapitate al proprietario dello stabile alla consegna dell'impianto.



Il gruppo acqua combinato JRGURED Combi **non** deve essere sottoposto a nessuna riparazione.

JRGURED Combi

Domestic water station

E 15-18

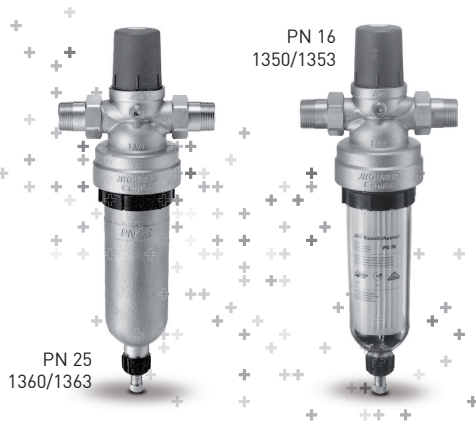

PN 25
1360/1363

PN 16
1350/1353

Installation instructions

Please read carefully the installation instructions. The used symbols mean:



Warning

This symbol point out a information, ignoring of it can cause extensive material damage. The security information has to be observed.



Note

This symbol point out a information, which indicate important details concerning the use. Ignoring of it can result in trouble.

General

The JRGURED Combi domestic water station is a multiple fitting for water systems*, consisting of a fine filter and a pressure reducing valve.

* Other applications on request.

The filter element employed in the JRGURED Combi is only for retaining ingested suspended particles. It in no way replaces any desired or necessary water treatment (softening, sterilization, etc.).

Operating range

The JRGURED Combi domestic water station is authorized for the following operating ranges:

JRG Code 1350/1353 PN 16

Water temperature:	max. 30°C
Primary pressure:	max. 16 bar
Secondary pressure (adjustable):	2–6 bar*

JRG Code 1360/1363 PN 25

Water temperature:	max. 30°C**
Primary pressure:	max. 25 bar
Secondary pressure (adjustable):	2–6 bar*

* Other pressure settings to order

** With filter element JRG Code 1839 to 70°C

Identification

- 1, 1¼, 1½, 2 (DN/valve size)
- JRGURED Combi (name of fitting)
- JRG (manufacturer)
- Flow direction arrow



Note

Seals made of **AFM 34** should **never** be used with grease or oil.
(AFM = Asbestos Free Material).

Factory setting

The JRGURED Combi domestic water station is factory set to a secondary pressure of 4 bar.

Installation requirements



During the installation of the JRGURED Combi, domestic water station, relevant regulations of the local water supply utility must be observed.

Installation



The JRGURED Combi domestic water station must be fitted only with suitable tools.

Mounted position



The JRGURED Combi domestic water station must be mounted in a horizontal pipe, and easily accessible.

A minimum space of 60 mm must be allowed under the filter so that it can be dismantled for maintenance. If a hose is used for drainage, this distance must be increased accordingly.



JRGURED Combi domestic water stations with a clear plastic filter cup must not be exposed to continuous strong sunlight. If the filter is installed in an aggressive vicinity or in rooms with uncontrollable environment (solvents and/or cleaning agent vapors etc.) the transparent filter cup must be protected accordingly or replaced by a gunmetal filter cup. We will be pleased to advise you in cases of doubt.

Commissioning



Before putting the JRGURED Combi domestic water station into operation, thoroughly flush the in feed pipe.

Resetting the pressure reducing valve



Any change to the factory pressure setting is carried out exclusively on the responsibility of the person doing so. For resetting the pressure, please refer to the separate operating- and maintenance instructions.

Maintenance



The fine filter must be maintained according to the separate operating and maintenance instructions. These are to be given to the building owner when handing over the installation.



Repairs to the JRGURED Combi domestic water station must **not** be attempted.

Georg Fischer JRG AG

Hauptstrasse 130

CH-4450 Sissach

Phone +41 (0)61 975 22 22, Fax +41 (0)61 975 22 00

info.jrg.ps@georgfischer.com

Georg Fischer JRG SA

Via Boscioro 20

CH-6962 Viganello/Lugano

Phone +41 (0)91 972 26 26, Fax +41 (0)91 972 26 27

ti.jrg.ps@georgfischer.com

Georg Fischer GmbH

Nördliche Grünauerstrasse 65

D-86633 Neuburg/Donau

Phone +49 (0)8431 5817-0, Fax +49 (0)8431

5817-20 info.jrg.ps@georgfischer.com

www.gfps.com

Ident. Nr. 350109458/ 02.25 / ©Georg Fischer JRG AG

BFS Code 1161530_v1_02_2025

Production: GF BFS / SDE

Einbaudatum: Date de montage: Data d'installazione: Built-in date:

Ihr Installateur: Votre installateur: Il vostro installatore: Your plumber:

JRG

+GF+