

# Uponor Tecto TN/TL

EN Technical information

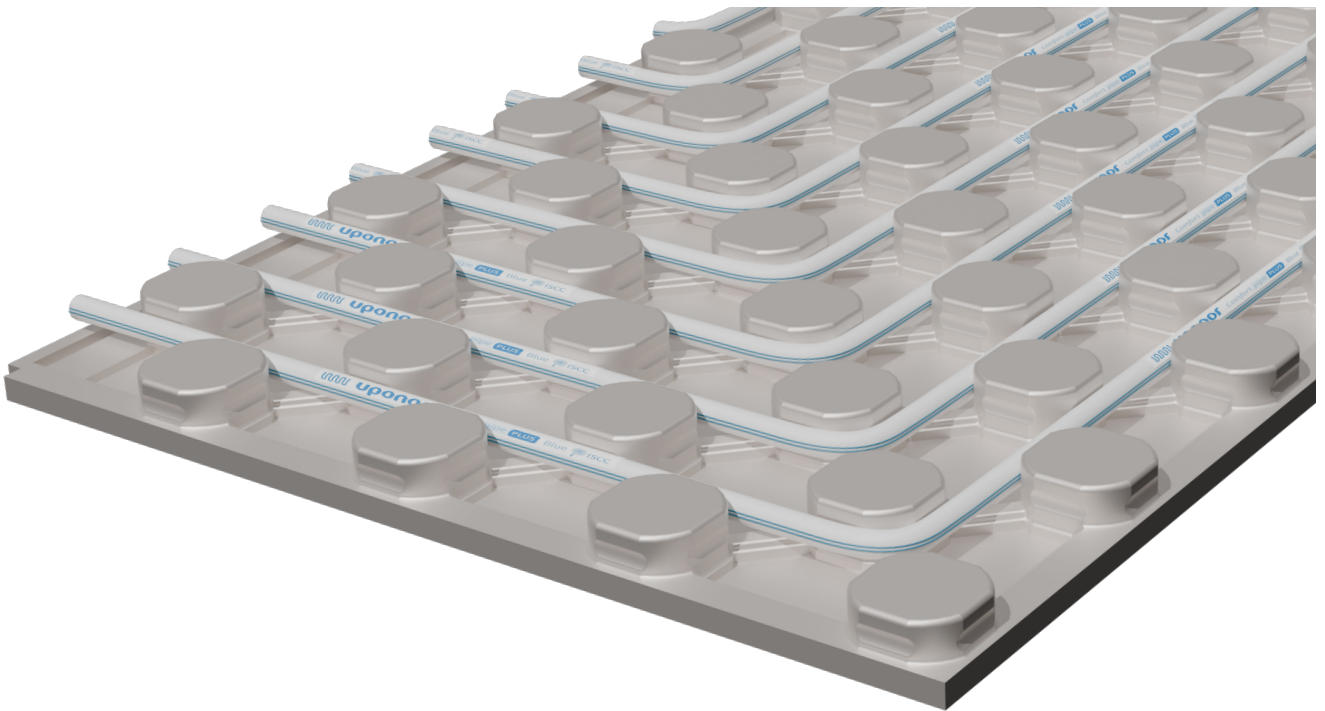

# Table of contents

<b>1</b>	<b>System description.....</b>	<b>3</b>
1.1	Benefits.....	3
1.2	Components.....	3
1.3	Copyright and disclaimer.....	4
<b>2</b>	<b>Planning/ design.....</b>	<b>5</b>
2.1	Floor constructions.....	5
2.2	Dimensioning diagrams.....	5
2.3	Pressure drop diagrams.....	11
<b>3</b>	<b>Installation.....</b>	<b>12</b>
3.1	Installation process.....	12
<b>4</b>	<b>Technical data.....</b>	<b>13</b>
4.1	Technical specifications.....	13

# 1 System description



The Uponor Tecto is an underfloor heating and cooling system for single-family and commercial buildings. The system combines comfort, energy efficiency, and economy and is suitable for 14 mm - 17 mm Uponor pipe dimension.

The Uponor Tecto is used for heating in winter and cooling in summer. The large area and a uniform heat distribution ensure a comfortable room temperature with mild radiant heat. The correct system pipe positioning at a fixed height, variable distance and uniform screed thickness is essential for comfortable and energy-efficient surface heating and cooling.

## 1.1 Benefits

- **Easy and flexible:** very few optimally matched system components
- **Reliable:** long-lifetime proven technology
- **Functional:** can be used both as a heating and cooling system
- **Compliant:** nub panels for a pipe fixation as per standards
- **Appliance:** laying distances in a 5 cm grid ensures a uniform heat or cold distribution
- **Suitable:** the foil will not be separated when the pipe is laid and is ideal for liquid screed

## 1.2 Components

### Note

For more detailed information, product range and documentation, please visit the Uponor website: [www.uponor.com](http://www.uponor.com).

### Note

For detailed information about the product range, dimensions and availability, please refer to the Uponor price list.

## Uponor Tecto TN nub panel

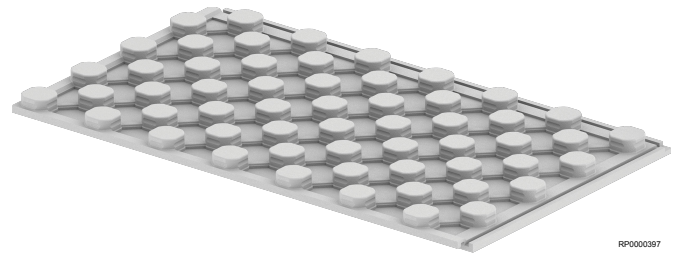

The Uponor Tecto TN nub panel is a white-foamed EPS insulation panel, available with a screed-tight connection and is suitable for 14 mm - 17 mm pipe dimensions.

It is integrated with thermal insulation as per DIN EN 13163.

The pipe spacing is based on the heating or cooling requirements: 7,5 cm, 15 cm, 22,5 cm or 30 cm.

## Uponor Tecto TL nub panel

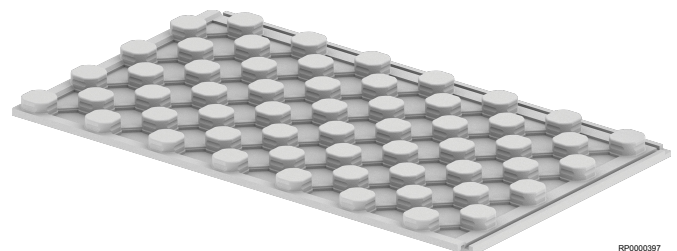

The Uponor Tecto TL nub panel is a white-foamed EPS insulation panel, available with one-sided foil for a screed-tight connection and is suitable for 14 mm - 17 mm pipe dimensions. The foil limits moisture penetration into the EPS board. This helps the screed dry faster during installation. It also increases the panel's resistance to mechanical damage.

It is integrated with thermal insulation as per DIN EN 13163.

The pipe spacing is based on the heating or cooling requirements: 7,5 cm, 15 cm, 22,5 cm or 30 cm.

## Uponor Comfort Pipe PLUS



RP0000202

The Uponor Comfort Pipe PLUS is a highly flexible PE-Xa pipe with 5 layers available in the dimension 16 x 2,0 mm.

The pipe fulfils the requirements for oxygen diffusion tightness as per DIN 4726.

## Uponor jointing technology



### Note

Only use fittings recommended by Uponor or its representatives.



RP0000417

Compression and Press joints are available to connect with respective pipes.

## 1.3 Copyright and disclaimer

“Uponor” is a registered trademark of Uponor Corporation.

Uponor has prepared this document solely for information purposes, images are only representations of the products. The content (text and images) of the document is protected by worldwide copyright laws and treaty provisions. You agree to comply with these when using the document. Modification or use of any of the content for any other purpose is a violation of Uponor's copyright, trademark, and other proprietary rights.

While Uponor has made all effort to ensure that the document is accurate, the company does not guarantee or warrant the accuracy of the information. Uponor reserves the right to change the product portfolio and the related documentation without prior notification, in line with its policy of continuous improvement and development.

This is a generic, European-wide document version. The document may show products that are not available in your location for

technical, legal, commercial, or other reasons. Therefore, check the Uponor product/price list in advance whether the product is deliverable in your location.

**Always make sure that the system or product complies with current local standards and regulations. Uponor cannot guarantee the full compliance of the product portfolio and related documents with all local regulations, standards, or working methods.**

**Uponor disclaims all warranties related to the content of this document, expressed or implied, to the fullest extent permissible unless otherwise agreed or statutory.**

**Uponor is under no circumstances liable for any indirect, special, incidental, or consequential damage/loss that results from the use or inability to use the product portfolio and related documents.**

For any questions or queries, please visit the local Uponor website or speak to your Uponor representative.

# 2 Planning/ design

## 2.1 Floor constructions

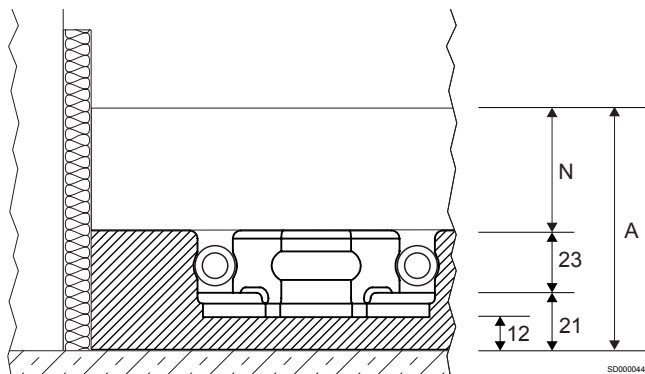

Item	Description
N	Minimum screed thickness
A	Structural height

As a result of combining insulations, the following constructions comply with the European minimum insulation requirements (refer to EN 1264-4 or EN 15377) for residential and non-residential buildings. Additional planning information for special insulation requirements for non-residential buildings that deviate from this are described under "Thermal insulation requirements for radiant heating".

### Floor construction tables

These abbreviations are used in the following construction tables:

Abbreviations	Description
CT	Cement screed
CAF	Anhydride liquid screed

## 2.2 Dimensioning diagrams

Bathrooms, showers, toilets and the like are excluded when determining the design flow temperature.

The limit curves must not be exceeded.

$\Delta\vartheta_{H,G}$  is found through the limit curve for the occupied zone with the smallest pipe spacing.

The design supply water temperature maximum must be:

$$\Delta\vartheta_{V,des} = \Delta\vartheta_{H,G} + \Delta\vartheta_i + 2.5 \text{ K.}$$

### Abbreviations

These abbreviations are used in the following diagrams:

In cooling mode the supply water temperature depends on the dew point temperature, therefore a humidity sensor has to be installed.

The following diagrams results are accurate and in accordance with EN 1264.

Abbreviations	Unit	Description
$A_{F,max}$	$m^2$	Maximum surface area of the heating/ cooling area
$q_c$	$W/m^2$	Specific thermal output of embedded cooling systems
$q_{des}$	$W/m^2$	Design specific thermal output of floor heating systems
$q_{G,max}$	$W/m^2$	Maximum limit of specific thermal output of floor heating systems
$q_H$	$W/m^2$	Specific thermal output of embedded heating systems, excluding floor heating
$q_N$	$W/m^2$	Standard thermal output of floor heating systems
$R_{\lambda,B}$	$m^2 K/W$	Thermal resistance of floor covering effective thermal resistance of carpeted covering
$R_{\lambda,ins}$	$m^2 K/W$	Thermal resistance of thermal insulation
$s_u$	mm	Thickness of the layer above the pipe
$T$	cm	Pipe spacing
$\vartheta_{F,max}$	$^{\circ}C$	Maximum floor surface temperature
$\vartheta_H$	$^{\circ}C$	Average temperature of the heating medium
$\vartheta_i$	$^{\circ}C$	Standard indoor room temperature
$\Delta\vartheta_i$	K	Temperature difference between designed room temperature and actual room temperature
$\Delta\vartheta_c$	K	Temperature difference between room and cooling medium for cooling systems
$\Delta\vartheta_{c,N}$	K	Standard temperature difference between room and cooling medium for cooling systems
$\Delta\vartheta_H$	K	Temperature difference between heating medium and room
$\Delta\vartheta_{H,G}$	K	Limit temperature difference between heating medium and room for floor heating systems
$\Delta\vartheta_{H,N}$	K	Standard temperature difference between heating medium and room for heating systems, with the exception of floor heating
$\Delta\vartheta_{V,des}$	K	Design temperature difference between flow of heating medium and room of floor heating systems, determined by room with $q_{max}$
$\lambda_u$	$W/mK$	Thermal conductivity

## Uponor Comfort Pipe PLUS 16 x 2,0 mm with screed load distribution layer (su = 35 mm with $\lambda_u = 1,2 \text{ W/mK}$ )

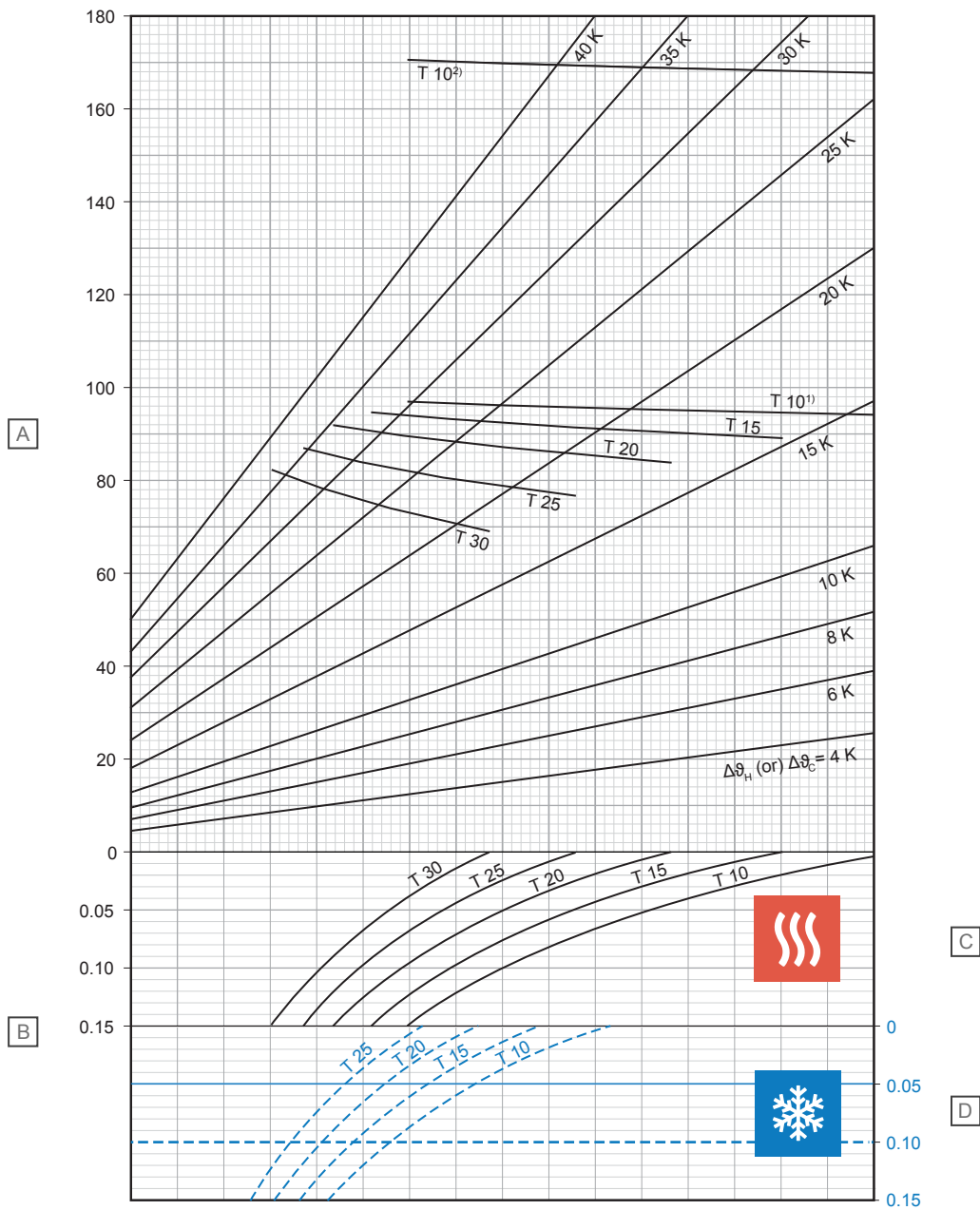

D10000246

Item	Unit	Description
A	W/m <sup>2</sup>	Specific thermal heating or cooling output [ $q_H$ or $q_C$ ]
B	m <sup>2</sup> K/W	Thermal resistance [ $R_{\lambda,B}$ ]

### C - Heating

T (cm)	$q_H$ (W/m <sup>2</sup> )	$\Delta\vartheta_{H,N}$ (K)
10	94,2	14,2
15	89,3	15,7
20	84,0	17,1
25	76,9	18,2
30	69,5	19,0

### D - Cooling

T (cm)	$q_C$ (W/m <sup>2</sup> )	$\Delta\vartheta_{C,N}$ (K)
10	36,7	8
15	32,6	8
20	29,0	8
25	25,8	8

<sup>1)</sup> Limit curve valid for  $\vartheta_i$  20 °C and  $\vartheta_{F,max}$  29 °C or  $\vartheta_i$  24 °C and  $\vartheta_{F,max}$  33 °C

<sup>2)</sup> Limit curve valid for  $\vartheta_i$  20 °C and  $\vartheta_{F,max}$  35 °C

## Uponor Comfort Pipe PLUS 16 x 2,0 mm with screed load distribution layer (su = 45 mm with $\lambda_u = 1,2 \text{ W/mK}$ )

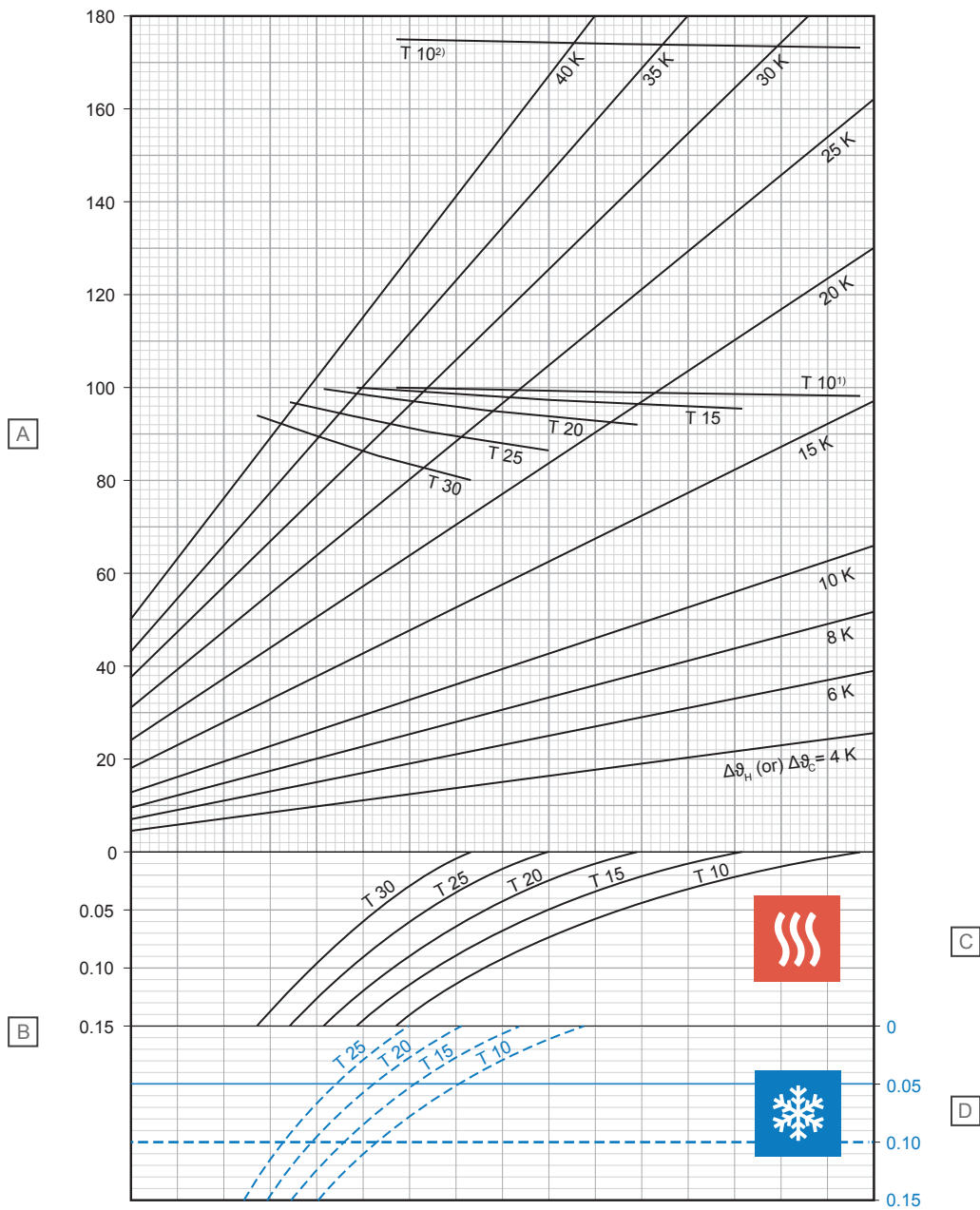

D10000247

Item	Unit	Description
A	W/m <sup>2</sup>	Specific thermal heating or cooling output [q <sub>H</sub> or q <sub>C</sub> ]
B	m <sup>2</sup> K/W	Thermal resistance [R <sub>A,B</sub> ]

### C - Heating

T (cm)	q <sub>H</sub> (W/m <sup>2</sup> )	Δθ <sub>H,N</sub> (K)
10	98,4	15,7
15	95,7	17,7
20	92,4	19,7
25	86,9	21,4
30	80,8	22,9

### D - Cooling

T (cm)	q <sub>C</sub> (W/m <sup>2</sup> )	Δθ <sub>C,N</sub> (K)
10	35,2	8
15	31,4	8
20	28,0	8
25	25,0	8

<sup>1</sup>) Limit curve valid for θ<sub>i</sub> 20 °C and θ<sub>F, max</sub> 29 °C or θ<sub>i</sub> 24 °C and θ<sub>F, max</sub> 33 °C

<sup>2</sup>) Limit curve valid for θ<sub>i</sub> 20 °C and θ<sub>F, max</sub> 35 °C

## Uponor Comfort Pipe PLUS 16 x 2,0 mm with screed load distribution layer (su = 65 mm with $\lambda_u = 1,2 \text{ W/mK}$ )

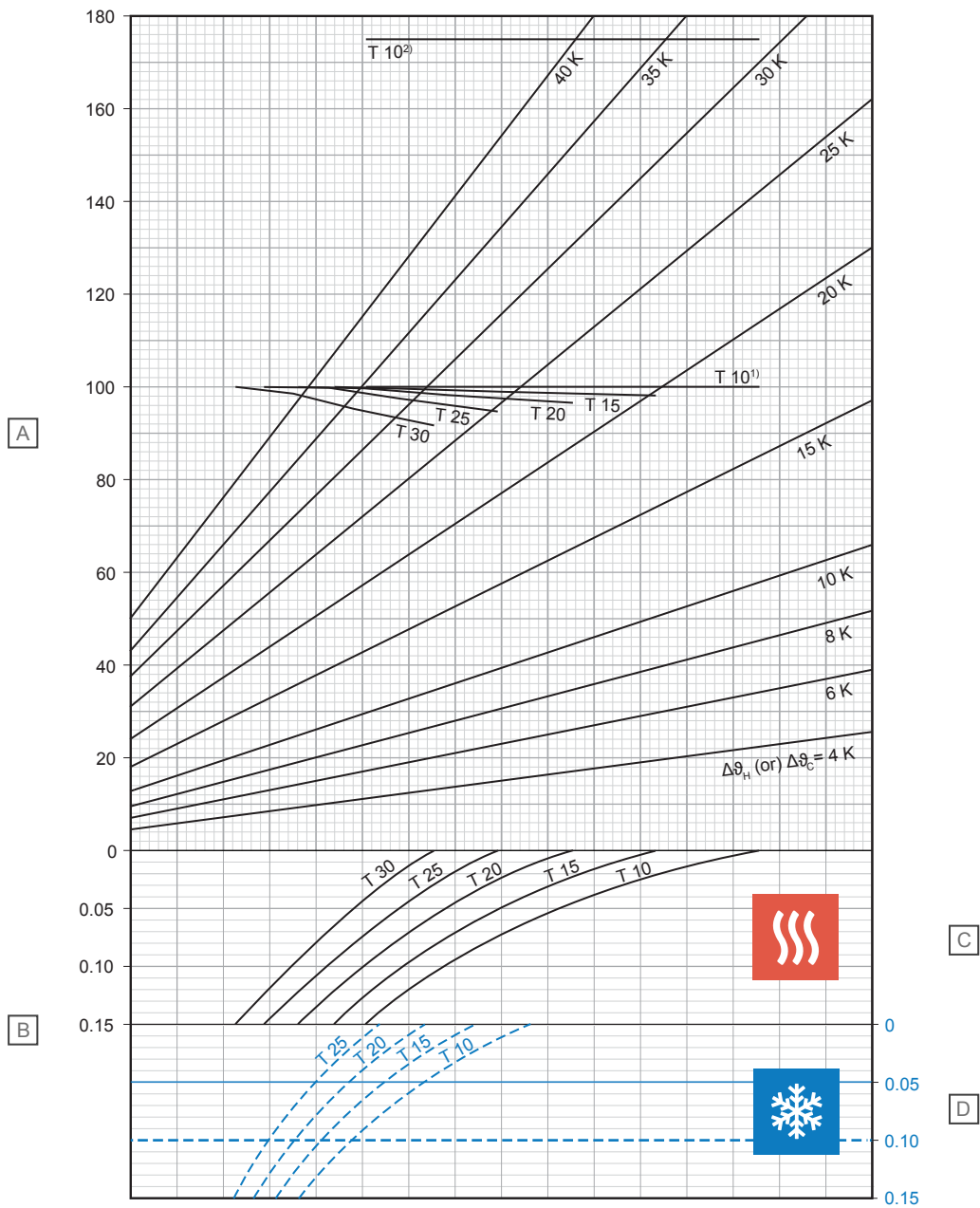

D10000248

Item	Unit	Description
A	W/m <sup>2</sup>	Specific thermal heating or cooling output [ $q_H$ or $q_C$ ]
B	m <sup>2</sup> K/W	Thermal resistance [ $R_{\lambda,B}$ ]

### C - Heating

T (cm)	$q_H$ (W/m <sup>2</sup> )	$\Delta\vartheta_{H,N}$ (K)
10	100,0	17,9
15	98,3	20,2
20	96,8	22,7
25	95,2	25,4
30	92,2	28,0

### D - Cooling

T (cm)	$q_C$ (W/m <sup>2</sup> )	$\Delta\vartheta_{C,N}$ (K)
10	32,3	8
15	29,0	8
20	26,1	8
25	23,5	8

<sup>1</sup>) Limit curve valid for  $\vartheta_i$  20 °C and  $\vartheta_{F,max}$  29 °C or  $\vartheta_i$  24 °C and  $\vartheta_{F,max}$  33 °C

<sup>2</sup>) Limit curve valid for  $\vartheta_i$  20 °C and  $\vartheta_{F,max}$  35 °C

## Uponor Comfort Pipe PLUS 16 x 2,0 mm with screed load distribution layer (su = 75 mm with $\lambda_u = 1,2 \text{ W/mK}$ )

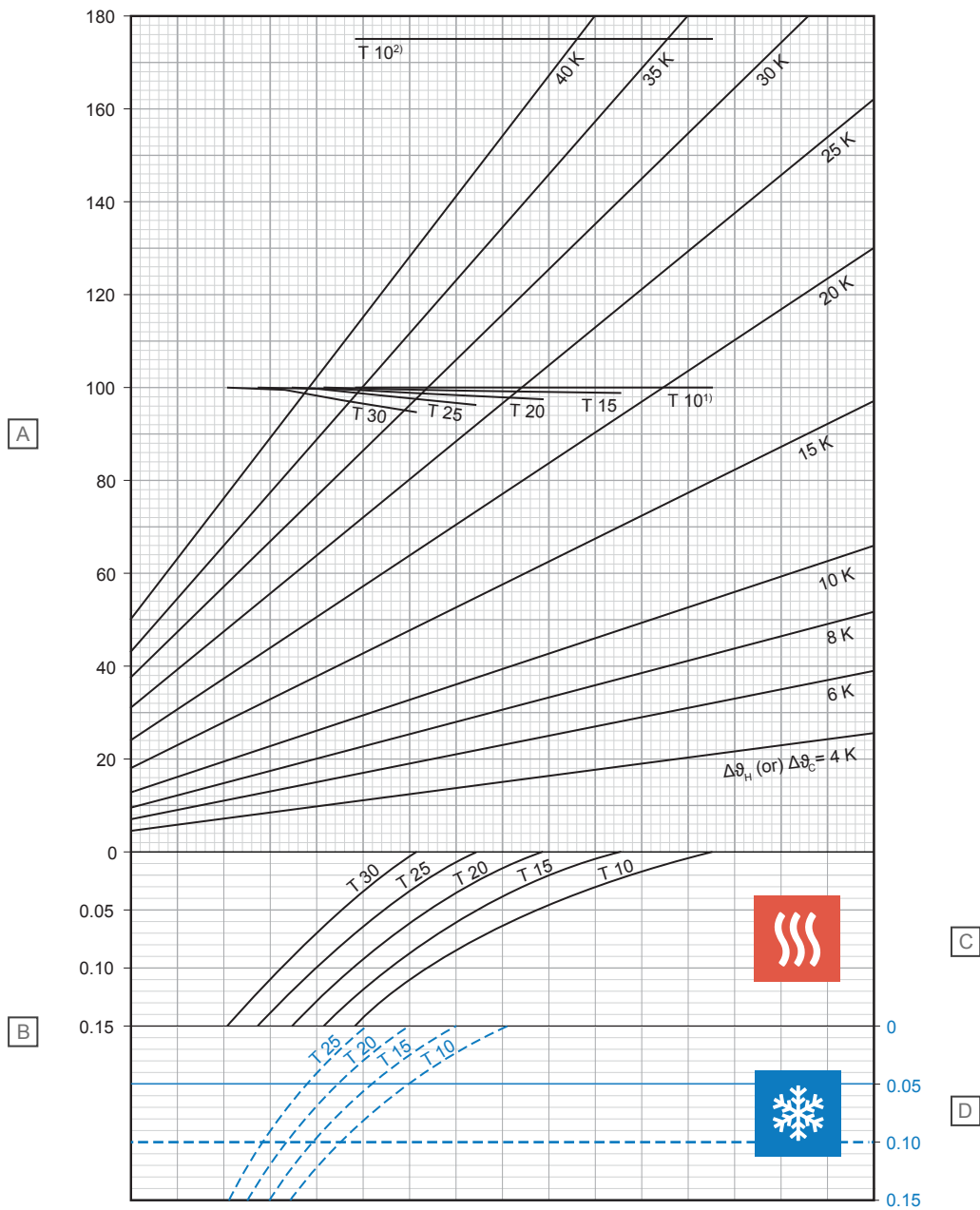

D10000249

Item	Unit	Description
A	W/m <sup>2</sup>	Specific thermal heating or cooling output [ $q_H$ or $q_C$ ]
B	m <sup>2</sup> K/W	Thermal resistance [ $R_{\lambda,B}$ ]

### C - Heating

T (cm)	$q_H$ (W/m <sup>2</sup> )	$\Delta\theta_{H,N}$ (K)
10	100,0	19,0
15	99,0	21,4
20	97,7	24,0
25	96,6	26,9
30	95,1	30,0

### D - Cooling

T (cm)	$q_C$ (W/m <sup>2</sup> )	$\Delta\theta_{C,N}$ (K)
10	30,9	8
15	27,9	8
20	25,2	8
25	22,8	8

<sup>1)</sup> Limit curve valid for  $\vartheta_i$  20 °C and  $\vartheta_{F,max}$  29 °C or  $\vartheta_i$  24 °C and  $\vartheta_{F,max}$  33 °C

<sup>2)</sup> Limit curve valid for  $\vartheta_i$  20 °C and  $\vartheta_{F,max}$  35 °C

## 2.3 Pressure drop diagrams

### Uponor Comfort Pipe PLUS

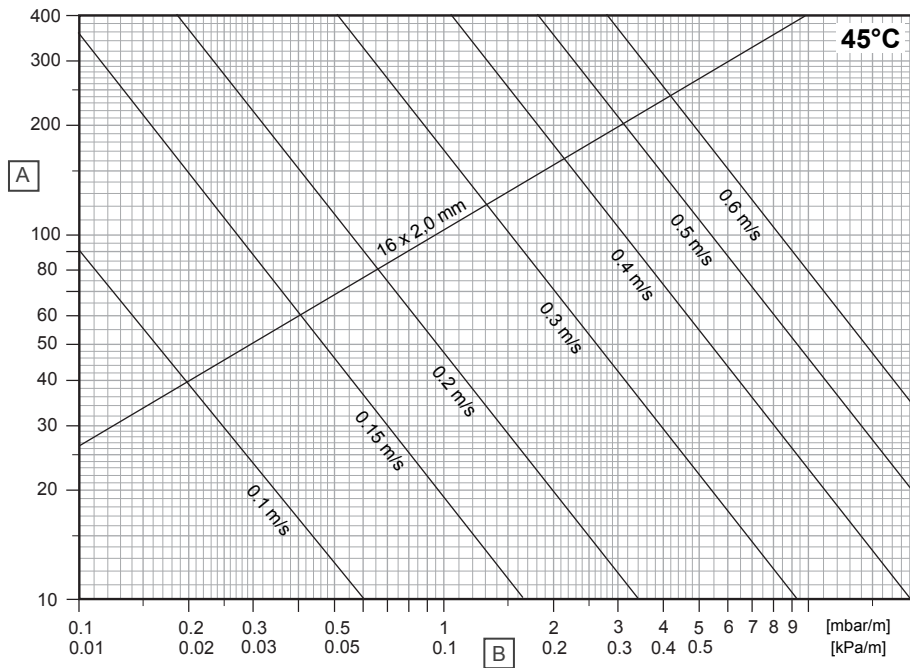

D10000350

Item	Unit	Description
A	kg/h	Mass flow rate
B	R	Pressure gradient

# 3 Installation

## 3.1 Installation process



### Note

Installation must be performed by a qualified person in accordance with local standards and regulations.

As a guidance, always read and follow the instructions given in respective Uponor installation manual.

### 1. Edging strip installation

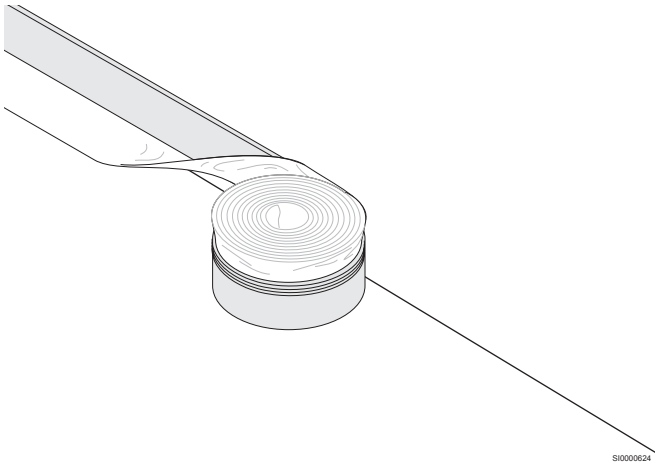

### 2. Panel installation

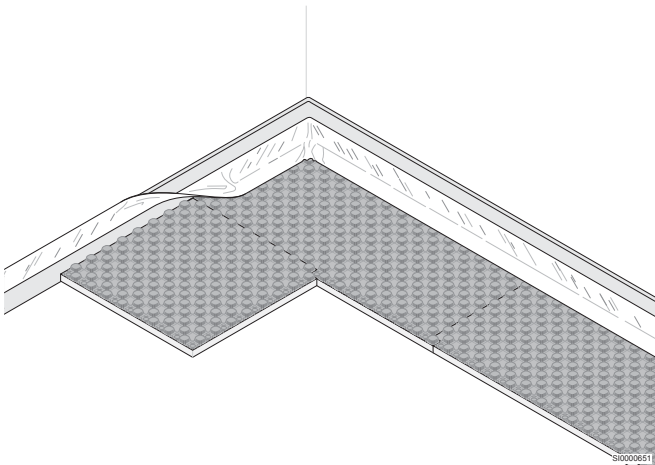

### 3. Pipe installation

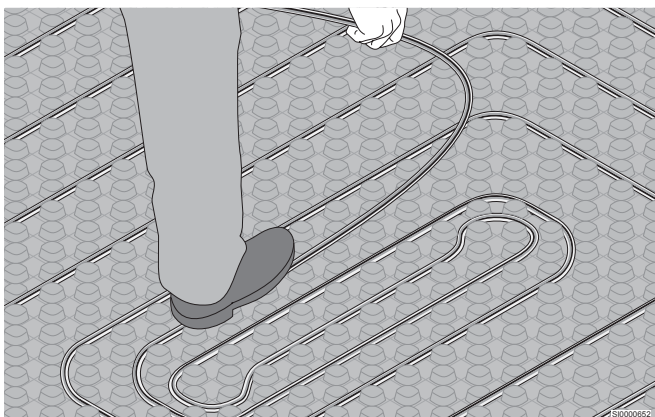

### 4. Connecting pipes to the manifold

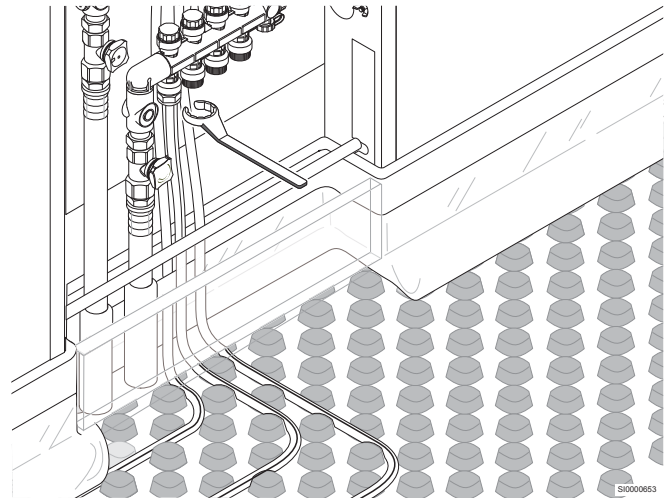

# 4 Technical data

## 4.1 Technical specifications

### Uponor Tecto TN nub panel

Description	Value	Value	Value	Value
Product name	TN 22-24	TN 26	TN 28-30	TN 30
Material	EPS	EPS	EPS	EPS
Reaction to fire (refer to EN 13501-1)	Class E	Class E	Class E	Class E
Thermal resistance	0,40 m <sup>2</sup> K/W	0,40 m <sup>2</sup> K/W	0,36 m <sup>2</sup> K/W	0,34 m <sup>2</sup> K/W
Thermal conductivity	0,038 W/mK	0,039 W/mK	0,042 W/mK	0,044 W/mK
Compressive stress	CS(10) 110 ≥ 110 kPa	CS(10) 140 ≥ 140 kPa	CS(10) 160 ≥ 160 kPa	CS(10) 180 ≥ 180 kPa
Pipe spacing	7,5, 15, 22,5, 30 cm	7,5, 15, 22,5, 30 cm	7,5, 15, 22,5, 30 cm	7,5, 15, 22,5, 30 cm
Total height	44 mm	44 mm	44 mm	44 mm
Type of system	Wet system	Wet system	Wet system	Wet system
Load distribution layer	Cement screed or anhydrite screed	Cement screed or anhydrite screed	Cement screed or anhydrite screed	Cement screed or anhydrite screed
Screed volume between nubs	approx. 18,5 l/m <sup>2</sup>	approx. 18,5 l/m <sup>2</sup>	approx. 18,5 l/m <sup>2</sup>	approx. 18,5 l/m <sup>2</sup>

### Uponor Tecto TL nub panel

Description	Value	Value	Value	Value
Product name	TL 22-24	TL 26	TL 28-30	TL 30
Material	EPS	EPS	EPS	EPS
Reaction to fire (refer to EN 13501-1)	Class E	Class E	Class E	Class E
Thermal resistance	0,40 m <sup>2</sup> K/W	0,40 m <sup>2</sup> K/W	0,36 m <sup>2</sup> K/W	0,34 m <sup>2</sup> K/W
Thermal conductivity	0,038 W/mK	0,039 W/mK	0,042 W/mK	0,044 W/mK
Compressive stress	CS(10) 110 ≥ 110 kPa	CS(10) 140 ≥ 140 kPa	CS(10) 160 ≥ 160 kPa	CS(10) 180 ≥ 180 kPa
Pipe spacing	7,5, 15, 22,5, 30 cm	7,5, 15, 22,5, 30 cm	7,5, 15, 22,5, 30 cm	7,5, 15, 22,5, 30 cm
Total height	44 mm	44 mm	44 mm	44 mm
Type of system	Wet system	Wet system	Wet system	Wet system
Load distribution layer	Cement screed or anhydrite screed	Cement screed or anhydrite screed	Cement screed or anhydrite screed	Cement screed or anhydrite screed
Screed volume between nubs	approx. 18,5 l/m <sup>2</sup>	approx. 18,5 l/m <sup>2</sup>	approx. 18,5 l/m <sup>2</sup>	approx. 18,5 l/m <sup>2</sup>

### Uponor Comfort Pipe PLUS

	Value
Pipe designation	Uponor Comfort Pipe PLUS 16 x 2,0 mm
Pipe dimension	16 x 2,0 mm
Pipe length	120; 240; 640 m
Material	PE-Xa, five-layer pipe
Colour	White with two blue longitudinal stripes
Manufacturing	Refer to EN ISO 15875
Certificates	KOMO, DIN CERTCO
Area of application	Class 4 + 5 / 6 bar (EN ISO 15875)
Max. operating temperature <sup>1)</sup>	90 °C (EN ISO 15875)
Max. operating pressure	6 bar at 70° C
Pipe jointings	Uponor screw connection, Uponor Smart press coupling, Uponor Q&E technology
Weight	0,091 kg/m
Water content	0,11 l/m

	Value
Oxygen tightness	Refer to ISO 17455; DIN 4726
Density	0,934 g/cm <sup>3</sup>
Material class	Class B2 and class E, DIN 4102 / EN 13501
Min. bending radius	8 x D; free-hand bending (128 mm) 5 x D; supported bending (80 mm)
Pipe roughness	0,007 mm
Ideal installation temperature	≥ 0 °C
UV protection	Opaque cardboard (store remaining quantities in the cardboard box)

1) When more than one design temperature appears for any class, the times should be aggregated (e.g. the design temperature profile for 50 years class 5 is: 20 °C for 14 years followed by 60 °C for 25 years, 80 °C for 10 years, 90 °C for 1 year and 100 °C for 100h).

**Uponor GmbH**

Industriestraße 56,  
D-97437 Hassfurt, Germany

1188272 v1\_04\_2026  
GF / SKA

Uponor reserves the right to change the product portfolio and the related documentation without prior notification, in line with its policy of continuous improvement and development.

