

Table of contents

1	System description	3
1.1	Approvals and certificates	3
1.2	Copyright and disclaimer	4
2	General information	5
2.1	Introduction to plastics	5
2.2	Manufacturing and processing methods	8
3	Aquasystem	10
3.1	Standards of GF Aquasystem	10
3.2	Specification of GF Aquasystem	10
3.3	Basics, terms, explanations	11
3.4	Raw material	12
3.5	Structure of pipes	13
3.6	Benefit	15
3.7	Tables	16
4	Installation	24
4.1	General precautions	24
4.2	Joining technology	25
4.3	Thermal expansions	46
4.4	Installation in shaft	48
5	Maintenance	50
5.1	Transport and storage	50
6	Technical data	51
6.1	Technical specifications	51

1 System description

GF Building Flow solutions



Georg Fischer's building division GF Building Flow Solutions is a leader in its sector and produces system solutions and high-quality components for the safe transport of water in public services and building technology.

GF Building Flow Solutions is committed to finding new ways to protect and manage water responsibly. With more than 30 production facilities worldwide and reaching over 100 countries, GF acquired **Hakan Plastik** in 2013 and has maintained its leadership in its field.

Founded in 1965, **Hakan Plastik** has achieved so many breakthroughs as the first company that produced the silent pipe in Turkey and has reflected the importance that it attaches to development and change to its products and services as well.

GF Hakan Plastik has production plant Cerkezkoy with the acquisition by GF global GF Product and process standards applicable worldwide have started to be applied. GF Hakan Plastik operates in the field of Building Technology (BT) plastic piping sector.

GF Hakan Plastik Training and Technology Center provides all its business partners with services with the aim of increasing the knowledge and awareness in the sector through both technical and practical trainings. Reaching out to a wider audience at the center such as the professionals serving the sector, university students and installers and providing diverse training and seminar programs for each stakeholder; the products of **GF Hakan Plastik** are promoted and information is provided about the accurate method of application of the products.

1.1 Approvals and certificates

Aquasystem has numerous international approvals and certificates that tested to the high-quality standards.

WRAS

Water Regulations Advisory Scheme (UK)

WRAS is a UK based certification body. The WRAS certificate shows that the products and materials in contact with water meet the required quality standards.

AENOR

Asociación Española de Normalización y Certificación (AENOR) (Spain)

The Spanish Association for Standardization and Certification creates the standards that govern Spanish products and services

SKZ

Das Kunststoff Zentrum

SKZ is a certification body accredited according to DIN EN/ISO IEC 17065:2013 (Germany).

CSTB

Centre Scientifique et Technique du Bâtiment (France)

The Scientific and Technical Center for Building, CSTB, is a public industrial and commercial company (EPIC), aiming to serve its clients and the public interest. Five key activities: research and expertise, assessment, certification, testing and the dissemination of knowledge.

KIWA

Keuringsinstituut voor Waterleidingsartikelen (Netherlands)

Key Areas: Testing, inspection and certification kiwa's initial aim was monitoring the quality of drinking water across the Netherlands.

ITC

Institut Pro Testování A Certifikaci-

Institute for testing and certification (Czech Republic)

EPD

Environmental Product Declaration

SEPRO (Ukraine)

TSE

Turkish Standard Institute

SEPRO (Ukraine)

TSE

Turkish Standard Institute

DVGW

German Technical and Scientific Association on Gas and Water (Deutscher Verein des Gas- und Wasserfaches e.V.) (Germany).

ABS

American Bureau of Shipping The American Bureau of Shipping is an international classification society that provides services to the maritime industry to promote safety, security and environmental protection.

KR

Korean Register of Shipping

KR has been delivering comprehensive technical services to our customers in a wide-range of industrial sectors including ship classification, energy & environment, third-party certification and naval services.

LR

Lloyd's Register of Shipping

Lloyd's Register is a leading provider of classification and compliance services to the marine and offshore industries, helping clients design, construct, operate, extend and decommission their assets safely and in line with environmental expectations.

DNV

Det Norske Veritas

Det Norske Veritas (DNV) was founded as a membership organization in Oslo, Norway in 1864. DNV is classification society and a recognized advisor for the maritime industry. They deliver world-renowned testing, certification and technical advisory services to the energy value chain including renewables, oil and gas, and energy management. They are one of the world's leading certification bodies, helping businesses assure the performance of their organizations, products, people, facilities and supply chains.

EAC/GOST (Russia)

The GOST certificate is the abbreviation of Gosstandard i.e. National Standard, a document attesting that a product conforms to Russian national standards (GOST R, GOST EN, GOST R IEC, GOST R ISO, etc.). It may be obligatory or voluntary. The Eurasian Conformity mark EAC has replaced GOST.

1.2 Copyright and disclaimer

"Uponor" and "GF" are a registered trademarks.

Uponor and GF has prepared this document solely for information purposes, images are only representations of the products. The content (text and images) of the document is protected by worldwide copyright laws and treaty provisions. You agree to comply with these when using the document. Modification or use of any of the content for any other purpose is a violation of Uponor's copyright, trademark, and other proprietary rights.

While Uponor and GF has made all effort to ensure that the document is accurate, the company does not guarantee or warrant the accuracy of the information. Uponor and GF reserves the right to change the product portfolio and the related documentation without prior notification, in line with its policy of continuous improvement and development.

This is a generic, European-wide document version. The document may show products that are not available in your location for technical, legal, commercial, or other reasons. Therefore, check the Uponor product/price list in advance whether the product is deliverable in your location.

Always make sure that the system or product complies with current local standards and regulations. Uponor cannot guarantee the full compliance of the product portfolio and related documents with all local regulations, standards, or working methods.

Uponor disclaims all warranties related to the content of this document, expressed or implied, to the fullest extent permissible unless otherwise agreed or statutory.

Uponor is under no circumstances liable for any indirect special, incidental, or consequential damage/loss that results from the use or inability to use the product portfolio and related documents.

For any questions or queries, please visit the local Uponor website or speak to your Uponor representative.

2 General information

2.1 Introduction to plastics

Structure and properties

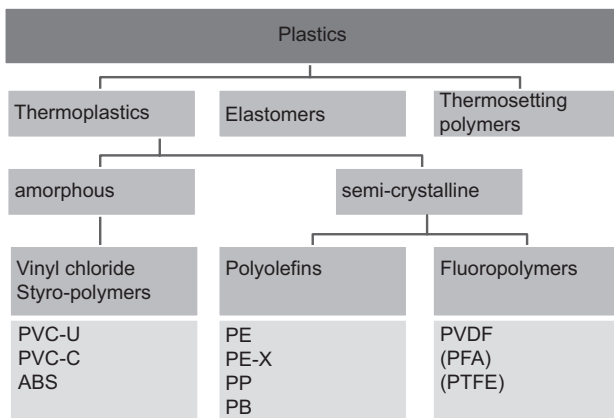

Polymers are organic compounds that are obtained either by the conversion of natural products (e.g. natural rubber, cellulose), or by synthesis from petroleum derivatives. Polymer chains, together with additives such as stabilisers and processing aids, produce the actual material - referred to as plastic. These chains consist mainly of carbon and hydrogen. Depending on the type, halogens (chlorine, fluorine), oxygen, nitrogen and sulphur can also be incorporated into the polymer chain. Polymers are also referred to as macromolecules, that is to say, a single polymer chain consists of more than 1,000 basic building blocks, the monomers. In piping system construction, mainly thermoplastics are used, which are processed into fittings and pipes with a technical process referred to as injection moulding and extrusion. Elastomers are used as sealing material in screw, flange and plug-in connectors. For example, thermosetting polymers are used as insulation foams or in glass-fibre reinforced liners.

Materials for pipelines

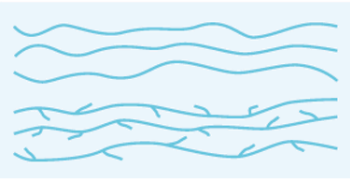

Plastics - main groups

The thermoplastics, the fusible agents of plastics, are subdivided into two groups:

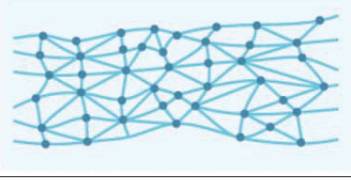
Main group		Property
Thermoplastics for example: PE, PVC		Linear or branched Fusible Soluble, swellable Plastic mouldable
Elastomer e.g. NBR, EPDM		Poorly linked Not fusible Not soluble, not swellable Not plastically mouldable
Thermosetting plastics e.g. PUR, Epoxy		Strongly linked Not fusible Not soluble, not swellable Not plastically mouldable

Subdivision of thermoplastics

Amorphous thermoplastics

In the case of the amorphous (Greek "without form") thermoplastics, the polymer chains are present as disordered, intertwined bundles. Typical representatives of this group are, for example, PVC and ABS. These plastics dissolve and swell easily by adding solvents and therefore, they are glued together when used in piping system construction.

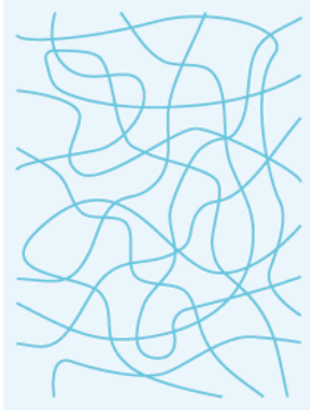

Semi-crystalline thermoplastics

The semi-crystalline thermoplastics contain not only the disordered, amorphous but also highly ordered regions in which the chains are arranged into crystalline structures. Representatives of this group are for example polyolefins such as polyethylene (PE), polypropylene (PP) and polybutene (PB). Due in part to the semi-crystalline structure, these plastics do not swell and not as easily soluble. Pipes made of semi-crystalline materials are therefore usually connected using a particular welding method

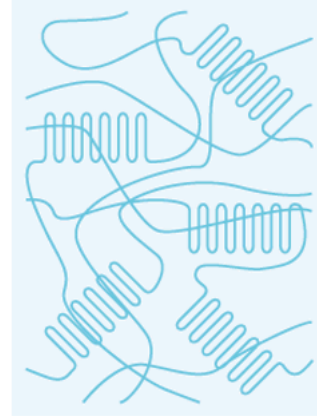

Mechanical properties

Glassy state (energy-elastic)



Rubber-elastic state (entropy-elastic)



Melt (liquid)

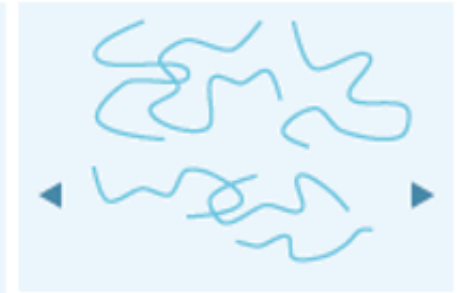

→ Rising temperature →

The mechanical properties of plastics, especially thermoplastics, are temperature dependent. At low temperatures below the glass-transition temperature T_g the chains become immobile and brittle, which leads to increased fragility. At higher temperatures ($T_g \leftarrow T \leftarrow T_m$), the chains become more mobile, causing semi-crystalline materials to gain toughness, but lose strength and rigidity. At this stage, amorphous plastics are already softening. Both the embrittlement and softening temperatures are characteristics of the individual types of plastic and dependent on their molecular structure. If the temperature continues to rise ($T \rightarrow T_m$), the semi-crystalline thermoplastic is also present as a melt.

Application of temperature

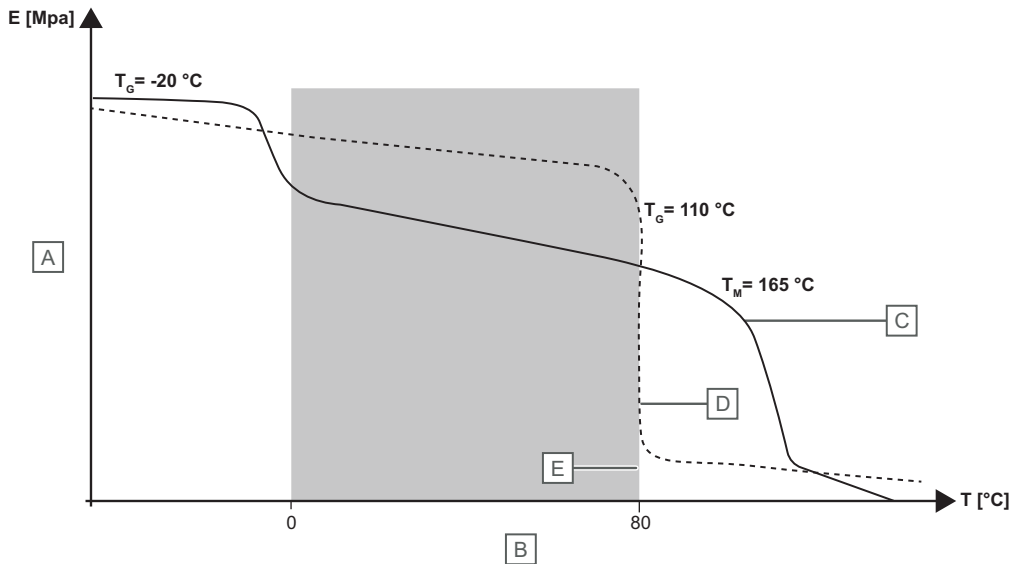

Pos.	Description
A	Modulus of elasticity (rigidity)
B	Temperature
C	Semi-crystalline, here PP-H
D	Amorphous, here PVC-C
E	Application temperature

The application temperatures for semi-crystalline and amorphous thermoplastics vary due to their different properties. Semi-crystalline materials are preferably used at temperatures above their glass transition temperature. However, amorphous thermoplastics are used below the glass transition point. Plastics also tend to creep to progressive deformation under load. Their mechanical properties are not only temperature-dependent but also time-dependent. For use in piping system construction, the materials are therefore tested for their creep internal compressive strength in accordance with ISO 1167 and ISO 9080 in order to determine the maximum operating temperatures and voltages for a service life of 50 years. The characteristic values of GF Aquasystem pipe materials can be found in the relevant raw materials chapter.

Advantages

Compared to metallic materials, the following general advantages for plastics result:

Properties and advantages of plastics

Property	Advantage
Low density (Plastic: 0,9 - 1,8 g/cm ³)	Very light-weight
Chemical resistance	No corrosion as with metals
Low thermal conductivity	Minimum heat loss Low condensation Plastics are poor heat conductors, but good insulators Thermal conductivity: • PB: 0,19 W/(m-K) • PE: 0,38 W/(m-K) • PVC: 0,15 W/(m-K)
Tight connections due to a variety of connection technologies	Plastics can be welded, glued and clamped. Weld connections can be made absolutely tight without additives
Smooth surface	The smooth surface causes low pressure losses.

Plastics in the environment

The world is facing big challenges in the energy sector. These challenges include increasing energy consumption, the finite nature of fossil resources, rising energy prices and climate change. In order to satisfy the needs not only of today but also of future generations, sustainable development is essential. Plastics help to meet these challenges.

The products of GF Piping Systems are used by customers for years, sometimes decades. Even the smallest increases in efficiency - such as a suitable design - can significantly affect the environmental performance. GF Piping Systems therefore pursues a holistic approach in the development of piping systems. Sustainable solutions are only possible if the entire life cycle of the applications and products is considered.

Plastics save energy

In addition to the well-known technical advantages such as corrosion resistance, plastics also characterised by their ecological advantages. Its light weight and insulating properties make it suitable for a variety of energy-efficient applications: in vehicles, packaging, insulation and piping systems. Plastics are mainly made from crude oils. About four percent of the world's oil is processed into plastic. The efforts to reduce the consumption of oil and other fossil fuels, however, do not mean a renouncement of plastic - on the contrary: The use of plastics saves energy!

In a study, Plastics Europe has quantified how energy consumption and greenhouse gas emissions affect plastic products by replacing them with other materials.

Results

Plastic products enable significant savings in energy and reduce greenhouse gas emissions.

Replacing plastic products with other materials will in most cases increase energy consumption and greenhouse gas emissions

Replacing as many plastic products as possible with other materials would require over 50 % more energy than is consumed today throughout the life cycle of all plastic products. In other words: The plastic products on the market today have enabled energy savings of 2,400 million GJ per year. This is equal to an amount of 50 million tons of oil, spread over 200 very large oil tankers.

2.2 Manufacturing and processing methods

Raw materials

Raw materials required for the production of plastics are natural products such as cellulose, coal, crude oil and natural gas. At the refinery, crude oil is separated by distillation into several components. It is separated into boiling ranges, distillation results in gas, petrol, petroleum and gasoil. The residue is bitumen. All components consist of hydrocarbons, which differ in size and shape of the molecules. The most important component for the production of plastics is naphtha. Naphtha is broken up and converted into ethylene, propylene, butylene and other hydrocarbon compounds in a thermal cracking process (cracking process).

Manufacturing

Plastics are formed by connecting a large number of similar basic building blocks (monomers), using a chemical bond. The majority of the raw materials required for this purpose comes from the processing of crude oil, but in some cases raw materials from renewable sources are also used. Contrary to expectations, only about 4 % of crude oil products coming from the refinery go to the plastics industry. The chemical industry accounts for around 10 % of total crude oil consumption in Germany, including 6 % for plastics production. In the production of plastics, three different methods are used.

Use of petroleum in production areas

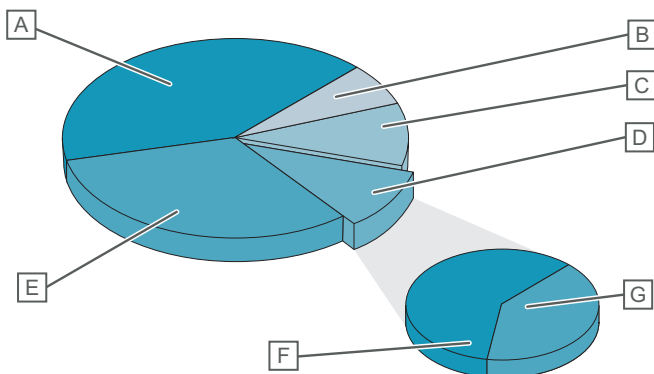

Pos.	Value	Description
A	41 %	Traffic
B	7 %	Miscellaneous
C	10 %	Industry
D	10 %	Chemistry
E	32 %	Heater
F	6 %	Plastic
G	4 %	Other materials

Manufacturing of plastics

Polymerisation	Polycondensation	Polyaddition
Polymerisation is the most widely used process in the synthesis of plastics. Polymerisation refers to the attachment of monomers to macromolecule chains without elimination of foreign substances. When using polymerisation, polyethylene, polybutene, polypropylene, polyvinyl chloride and other plastics, for example, are formed.	In the polycondensation process, equal and dissimilar monomers are arranged in a macromolecule chain with simultaneous elimination of a by-product, e.g. water, hydrochloric acid. Polycondensation is used, for example, in the manufacturing of phenolic resins and polyamides	When using polyaddition, macromolecules are formed from molecules of different chemical structure, but without elimination of a by-product. This process is used in the manufacturing of polyurethanes and epoxy resin, for example, araldite.

Processing

GF Piping Systems uses a variety of plastic processing techniques. A distinction is made between injection moulding, extrusion and foaming. The injection moulding process is used to produce fittings and valves. Pipes are extruded. Special fittings and pipes are foamed as well.

a- Injection moulding

An injection moulding machine is used to melt (plasticise) the respective material and injected into a mould - the moulding tool - under pressure. Inside the mould tool, the material is cooled and thus reverts to its solid state. The resulting volume shrinkage is compensated by very high pressures. By rotating the plasticising screw, material for the next component is added. After opening the tool, the finished part is removed. The void (the cavity) of the tool determines the shape and the surface structure of the finished part.

Components of a typical plasticising/injection unit

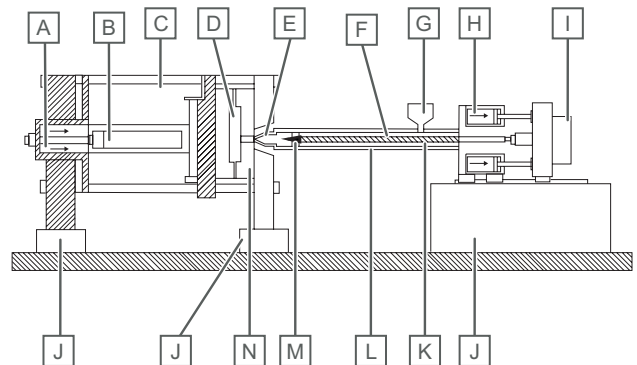

Pos.	Description
A	Locking cylinder
B	Opening cylinder
C	Opening and locking cylinder
D	Workpiece
E	Injection nozzle
F	Plasticising screw
G	Plastic pellets
H	Injection cylinder
I	Worm gear drive
J	Machine bed
K	Plasticising cylinder
L	Heater
M	Non-return valve
N	Moulding tool

b-Extruding

An extrusion machine integrates the following process steps:

1. Extruding
2. Shaping
3. Calibrating
4. Cooling
5. Removing
6. Separating

Components of a typical extrusion system

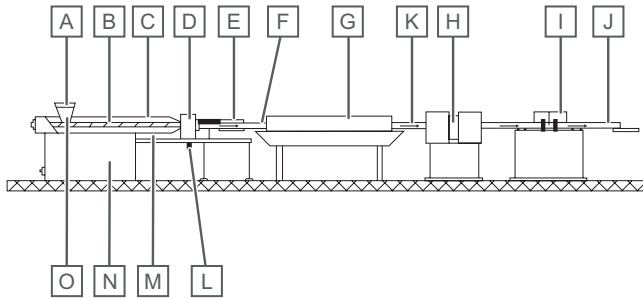

Pos.	Description
A	Hopper
B	Plasticising screw
C	Heater
D	Moulding tool (profile nozzle)
E	Calibration distance
F	Pipe
G	Cooling section
H	Haul-off/pulling machine
I	Device for cutting into lengths
J	Hollow section
K	Pipe
L	Compressed air
M	Plasticising cylinder
N	Extruder
O	Plastic pellets

The extruder system consists of the hopper, the plasticising cylinder, one or two plasticising screw(s) and the actuator. The tasks of the extruder's components are the same as in the injection unit during injection moulding. The extruder tool rests directly against the extruder, guiding the mass around a mandrel and shaping the profile of the pipe. For pipes under $d400$, tools with sieve rings or multiple webs are used for fixing. For larger pipes over $d400$, spiral distribution tools are used. The cooling section and calibration section are connected in the manufacturing of the pipe. This is possible by using vacuum tank calibration with multiple water showers. A caterpillar haul-off/ pulling machine is used to handle the pulling in pipe manufacturing. The speed of the haul-off/ pulling machine is adapted to the performance of the extruder. The separating unit must move with the extrudate (pipe) during cutting process.

3 Aquasystem

3.1 Standards of GF Aquasystem

System-specific standards and guidelines

DIN 8077 Polypropylene pipe systems, Dimensions

DIN 8078 Polypropylene Pipe systems general quality requirements, Testing

DIN EN ISO 15874 Parts 1-7 plastic piping systems for hot and cold water installations – polypropylene

Part 1 General information

Part 2 Pipes

Part 3 Fittings

Part 5 Fitness for purpose of the system

Part 7 / TS conformity assessment

TS 13715 Glass fibre reinforced, multilayer polypropylene pipes used for hot and cold pressure water supply systems

DVS 2207 Welding of thermoplastics

DVS 2208 Machinery and appliances for welding thermoplastics

3.2 Specification of GF Aquasystem

Aquasystem PP-R and PP-RCT

With more than thirty years of proven performance, Polypropylene Random Copolymer (PP-R) pipe and fittings have been used with premium quality throughout the world in buildings, industrial applications and marine sector.

Aquasystem pipes made from PP-R and PP-RCT are non-corrosive thanks to natural structure of PP-R are lightweight joined with heat fusion for permanently, leak-free joints.

Application Areas

		PP-R standard pipe system	PP-R UV resistant standard pipe system	PP-R Glass fiber reinforced pipe system	PP-R glass fiber reinforced climafaser pipe system	PP-R Al-foiled pipe system	PP-R UV resistant Al-foiled pipe system	PP-RCT monolayer pipe system	PP-RCT glass fiber reinforced pipe system
Main application areas	Potable water network	<input type="checkbox"/>	<input type="checkbox"/>	<input type="checkbox"/>	<input type="checkbox"/>	<input type="checkbox"/>	<input type="checkbox"/>	<input type="checkbox"/>	<input type="checkbox"/>
	Hot and cold water application	<input type="checkbox"/>	<input type="checkbox"/>	<input type="checkbox"/>	<input type="checkbox"/>	<input type="checkbox"/>	<input type="checkbox"/>	<input type="checkbox"/>	<input type="checkbox"/>
	HVAC	<input type="checkbox"/>	<input type="checkbox"/>	<input type="checkbox"/>	<input type="checkbox"/>	<input type="checkbox"/>	<input type="checkbox"/>	<input type="checkbox"/>	<input type="checkbox"/>
	Industrial clean water system	<input type="checkbox"/>	<input type="checkbox"/>	<input type="checkbox"/>	<input type="checkbox"/>	<input type="checkbox"/>	<input type="checkbox"/>	<input type="checkbox"/>	<input type="checkbox"/>
	Agriculture	<input type="checkbox"/>	<input type="checkbox"/>	<input type="checkbox"/>	<input type="checkbox"/>	<input type="checkbox"/>	<input type="checkbox"/>	<input type="checkbox"/>	<input type="checkbox"/>
	Irrigation	<input type="checkbox"/>	<input type="checkbox"/>	<input type="checkbox"/>	<input type="checkbox"/>	<input type="checkbox"/>	<input type="checkbox"/>	<input type="checkbox"/>	<input type="checkbox"/>
	Outdoor installation	-	-	-	-	-	<input type="checkbox"/>	-	-
Different application areas	Solar collectors	-	-	-	-	-	<input type="checkbox"/>	-	-
	Swimming pool system	<input type="checkbox"/> *)	<input type="checkbox"/> *)	<input type="checkbox"/> *)	<input type="checkbox"/> *)	<input type="checkbox"/> *)	<input type="checkbox"/> *)	<input type="checkbox"/> *)	<input type="checkbox"/> *)
	Central heating systems	<input type="checkbox"/> *)	<input type="checkbox"/> *)	<input type="checkbox"/> *)	<input type="checkbox"/> *)	<input type="checkbox"/> *)	<input type="checkbox"/> *)	<input type="checkbox"/> *)	<input type="checkbox"/> *)
	Shipbuilding	<input type="checkbox"/> *)	<input type="checkbox"/> *)	<input type="checkbox"/> *)	<input type="checkbox"/> *)	<input type="checkbox"/> *)	<input type="checkbox"/> *)	<input type="checkbox"/> *)	<input type="checkbox"/> *)

Recommended to its technical.

*) Application is suitable.

Product range of GF Aquasystem

Pipes

System	Aquasystem								
Material	PP-R						PP-RCT		
SDR	SDR6 PN20	SDR7,4 PN16	SDR11 PN10	SDR6 PN25	SDR7,4 PN20	SDR11 PN10	SDR6 PN20	SDR7,4 PN25	SDR9 PN22
							Climafaser		
Subcategory	Aquasystem monolayer			Aquasystem multilayer fiber reinforced			Aquasystem multilayer UV-resistant standard	Aquasystem multilayer fiber reinforced	
Dimensions [mm]	20	20	20	20	20	-	20	20	20
	25	25	25	25	25	-	25	25	25
	32	32	32	32	32	32	32	32	32
	40	40	40	40	40	40	40	40	40
	50	50	50	50	50	50	50	50	50
	63	63	63	63	63	63	63	63	63
	75	75	75	75	75	75	-	75	75
	90	90	90	90	90	90	-	90	90
	110	110	110	110	110	110	-	110	110
	125	125	125	125	125	125	-	125	125
	160	160	160	160	160	-	-	160	160
	200	200	200	-	-	-	-	-	-

Polypropylene (PP)

Polypropylene (PP) is a thermoplastic belonging to the group of polyolefins and thus is a semi-crystalline material. The density is lower than that of the other known thermoplastics. The mechanical properties, the chemical resistance and in particular the heat resistance have made polypropylene an important material in piping system construction as well. PP is formed by the polymerisation of propylene (C₃H₆) using, for example, Ziegler-Natta catalysts. Four different material variants are common in piping system construction:

Isotactic PP homopolymer (PP-H)

PP block copolymer (PP-B)

PP random copolymer (PP-R)

PP random copolymer with modified crystallinity and temperature resistance. (PP-RCT)

Due to the low modulus of elasticity and the high long-term creep strength at high temperatures, PP-R/RCT is predominantly used in the sanitary sector. PP-B is mainly used for sewage systems because of its high impact strength, especially at low temperatures, and the comparatively low temperature resistance. PP-H is mainly used for industrial applications.

3.3 Basics, terms, explanations

PN, Pressure Nominal

The abbreviation PN (nominal pressure) indicates a reference value that is representative for a pipe system. This reference value was used as the maximum working pressure only refers to a service life of 50 years at a working temperature of 20 °C in water media. This circumstance frequently leads to confusion. For an exact pipe classification under various operating conditions, last versions of the respective standards (DIN 8077/78 –EN ISO 15874-1/2/3 therefore only state the pipe series S or the diameter-wall thickness ratio SDR

SDR, Standard Dimensional Ratio

SDR is an index in use for the classification of plastic pipes, which describes the ratio between a pipe's outer diameter and its wall thickness.

$$SDR = \frac{d}{e}$$

d = outer diameter

e = wall thickness

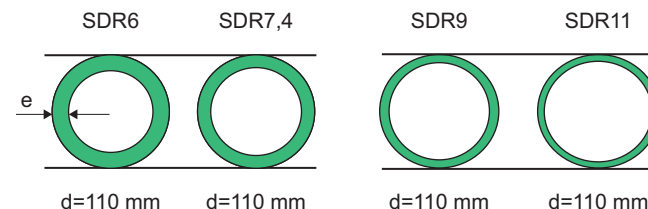

S, Pipe Series Number

The nominal pipe series number is a dimensionless index, which is used for the calculation of the wall thickness of pipes.

The following equation is used for the calculation of the pipe series number S:

$$S = \frac{SDR - 1}{2}$$

S, pipe series number

Example: Aquasystem pipe SDR 6 = S2,5

MRS, Minimum Required Strength

The MRS is used as a measure of a pipe material's → Pressure stability.

The material's → Hoop stress σ (in N/mm² = MPa) for the temperature 20 °C (water) and for the time 50 years is read from its long-term regression curves (→ Stress-rupture test).

One obtains the MRS by rounding down to the highest Renard number which is smaller than, or equal to the hoop stress.

Example: σ (50a, 20 °C, water) = 10,58 N/mm², . e. MRS10

Examples: PP-H and PE100 pipes are graded MRS10.

Safety factor (SF)

Safety factors are important, for example, in determining a pipe's required dimensions, its pressure rating or its anticipated service life.

Hoop stress (circumferential stress)

If every point of an elastic hoop (e.g. of an O-ring) is pressed uniformly in an outward direction, the hoop becomes larger and its material is put under stress. In analogy, a plastic pipe expands (at least very slightly) when subjected to inside pressure. Its circumference becomes enlarged, causing a so-called hoop (or circumferential) stress in the pipe material. This stress is an important means of quantifying a pipe's state of tension. The relationship between the inside pressure and the pipe material's hoop stress is given by the → Vessel formula.

Vessel formula

A pipe's → Hoop stress σ depends on the operating pressure p , on the wall thickness e and on the diameter d_0 . The so-called vessel formula gives the relationship between these quantities.

$$\sigma = (p/10) (d_0 - e)/2e$$

σ = hoop stress in N/mm²

p = inside pressure in bar

d_0 = outer diameter

e = wall thickness

The classes of application

The operating conditions of water distribution and heating are specified for four different classes of application (EN ISO 15874-1). Each class of application refers to a typical field of use and for a period of 50 years. Each class of application must be associated with the pressure it is designed for (operating system pressure). This information is assigned to each pipe in the following format: class of application/pressure, for example 1/10 bar. It means the pipe is categorized as class 1 and has the maximum operating pressure of 10 bar.

The classes of application according to **EN ISO 15874-1**

class 1 (supply of hot water of 60 °C, service life 50 years)

class 2 (supply of hot water of 70 °C, service life 50 years)

class 4 (floor heating, low temperature heaters, service life 50 years, assuming (in total for the entire lifetime) 2,5 years at the operating temperature of 20 °C, 20 years at the operating temperature of 40 °C, 25 years at the operating temperature of 60 °C, 2,5 years at the operating temperature of 70 °C)

class 5 (high temperature heaters, service life 50 years, out of which (in total for the entire length of service life) 14 years at the operating temperature of 20 °C, 25 years at the operating temperature of 60 °C, 10 years at the operating temperature of 80 °C, 1 year at the operating temperature 90 °C).

Maximum operating pressure (4, 6, 8, 10 bar) corresponding to the application class is calculated and assigned for each material and pipe series S.

The advantages of Aquasystem



- Longevity
- Corrosion resistant
- Hygienically safe
- Resistant against many chemicals
- High environmental compatibility
- Less pipe roughness
- Sound insulating characteristics (water hammer)
- Very good welding properties
- High mechanical stability
- Low thermal conductivity
- Lighter in weight than steel and copper
- Easy processing
- Installation aid and fixings

3.4 Raw material

Pipes are made of polypropylene random copolymer, also known as type 3 and also made of PP-RCT, polypropylene-random-copolymer with modified crystallinity, also known as type 4. Fittings are made of polypropylene random copolymer.

Aquasystem is designed and specified for a life time of 50 years with in the defined conditions. The material is suitable for hot and cold water and heating systems.

It is environmentally friendly and 100 % recyclable.

Aquasystem is produced with "virgin raw materials" that obtained from 1st quality approved international manufacturers with our superior quality understanding.

When using Aquasystem PP-R/PP-RCT pipes, the pressure and temperature conditions according to DIN 8077 with safety factor of 1,5 table, refer to the chapter "Temperature, pressure and service life". With regard to pressure and temperature, the operating conditions in the following table are to be used for pipes and pipe connections. These figures refer to potable water installations based on a theoretical service life of 50 years.

Operating conditions for pipes and pipe joints assemblies

	Working pressure (fluctuating) [bar]	Temperature [°C]	Frequency of use, in hours per year
Cold water pipes	0 - 10	Up to 25*)	8760
Hot water pipes	0 - 10	Up to 60	8710
		Up to 85	50

*) Reference temperature for creep rupture strength: 20 °C

3.5 Structure of pipes

GF Aquasystem PP-R and PP-RCT pipes are produced as monolayer and multilayer structure.

Monolayer structure

Monolayer PP-R pipe



Pos.	Description
A	PP-R

SDR6 (PN20)

SDR7,4 (PN16)

SDR11 (PN10)

Monolayer PP-RCT pipe

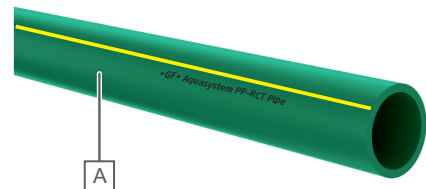

Pos.	Description
A	PP-RCT

SDR7,4

SDR9

Multilayer (Composite) structure

Multilayer PP-RCT pipe

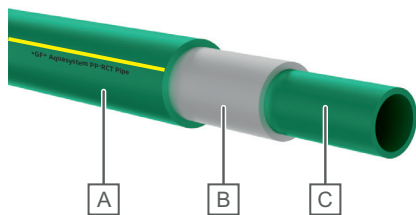

Pos.	Description
A	PP-RCT
B	PP-RCT + Fiber composite
C	PP-RCT

SDR7,4 (PN25)

SDR9 (PN22)

Multilayer PP-R pipe

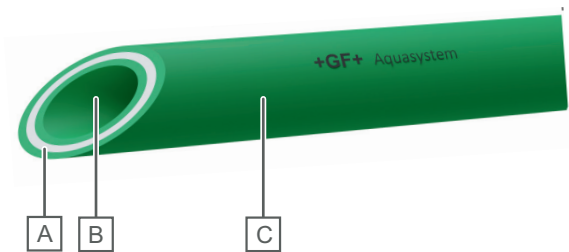

Pos.	Description
A	PP-R + Fiber composite
B	PP-R
C	PP-R

SDR6 (PN25)

SDR7,4 (PN20)

SDR11 (PN10)

Composite structure

PP-R glassfiber reinforced pipes

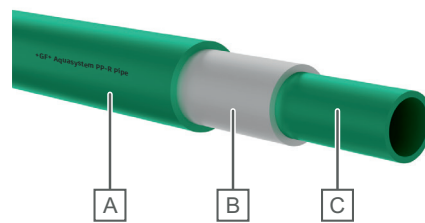

Pos.	Description
A	External layer: PP-R
B	Middle layer: Glass fiber reinforced PP-R
C	Inner layer: PP-R

Aquasystem glass fiber reinforced pipe is a multilayer fiber composite pipe. The pipe is manufactured using a multilayer extrusion process. The production process allows glass fibers to be combined with the polypropylene material of the middle layer of the pipe. This composite structure limits the thermal expansion.

Advantages of Aquasystem PP-R glass fiber reinforced pipes:

- The linear expansion is reduced by at least 75 % compared with standard PP pipes

Expansion in comparison

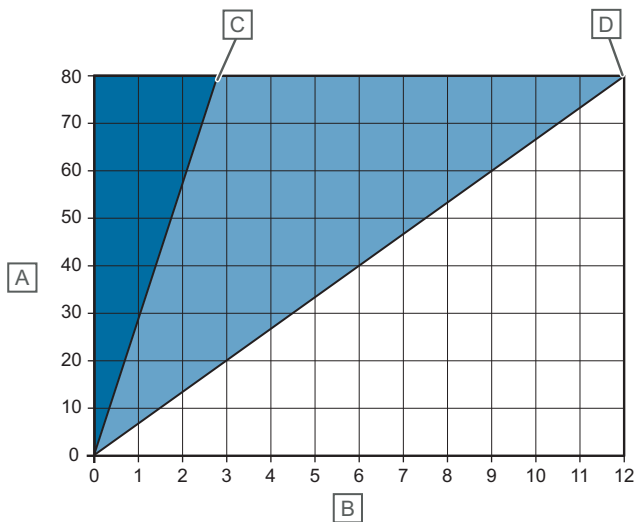

Pos.	Unit	Description
A	ΔT [K]	Temperature difference
B	ΔL [mm/m]	Expansion
C	-	Fibre composite pipe
D	-	Standard PP pipe

Graph for determination of expansion

- Thanks to coefficient of linear expansion ratio, pipes the support intervals can be enlarged and the number of clamps can be reduced

Support spacings PP pipe and fibre composite pipe



PP Pipe



Fibre composite pipe approximately 30 % more fixing distance

- High stability
- Lightweight- than stainless steel, steel and copper pipes, thereby easier handling for transport and at site
- Easy to handle
- High impact rate

PP-RCT glassfiber reinforced pipes

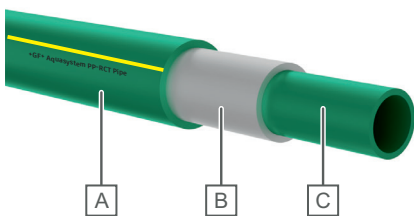

Pos.	Description
A	External layer: PP-RCT
B	Middle layer: Glass fiber reinforced
C	Inner layer: PP-RCT

With PP-RCT raw material, all the known advantages of PP-R are preserved, while fiber composite pipes can be produced with thinner wall thicknesses, higher stability at high temperatures and higher pressures.

Advantages of Aquasystem PP-RCT glassfiber reinforced pipes

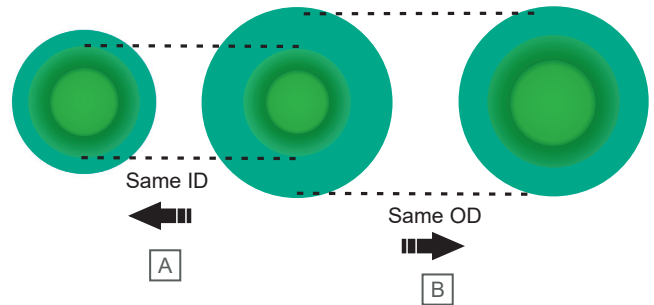
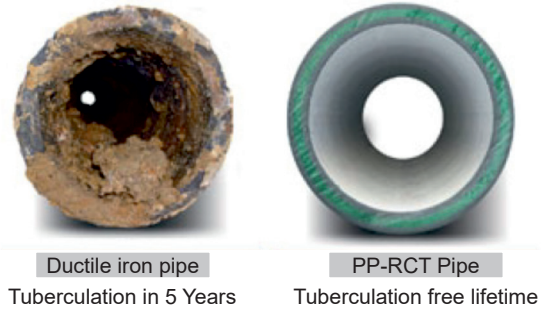

Pos.	Description
A	Similar hydraulic capacity reduced on smaller diameter
B	Reduced wall thickness-reduced weight carbon foot print

- SDR9 PP-RCT has higher flow rate 14 % at the same velocity than compare the fibre composite pipe SDR 7,4 PP-R
- SDR9 PP-RCT, 16 % lower weight than fibre composite pipe SDR 7,4 PP-R
- Internal pressure resistance improved
- Enhanced long-term durability
- Good impact resistance
- Fully compatible and weldable with Aquasystem PP-R
- PP-R and PP-RCT can be welded without restriction. Welding PP-RCT onto PP-R components can also be performed unrestricted. The German Welders Association guideline DVS 2207-11 is described processes of welding.
- For butt welding, the pipe and fitting/pipe must have the same SDR.
- In case of application of welded fittings, a reduced pressure load on the maximum operating pressure for pipes has to be taken into account.
- Corrosion free

When we look at the regression curves of PP-R and PP-RCT, they show the improved long-term performance of the PP-RCT material in the temperature range 70 - 95 °C.

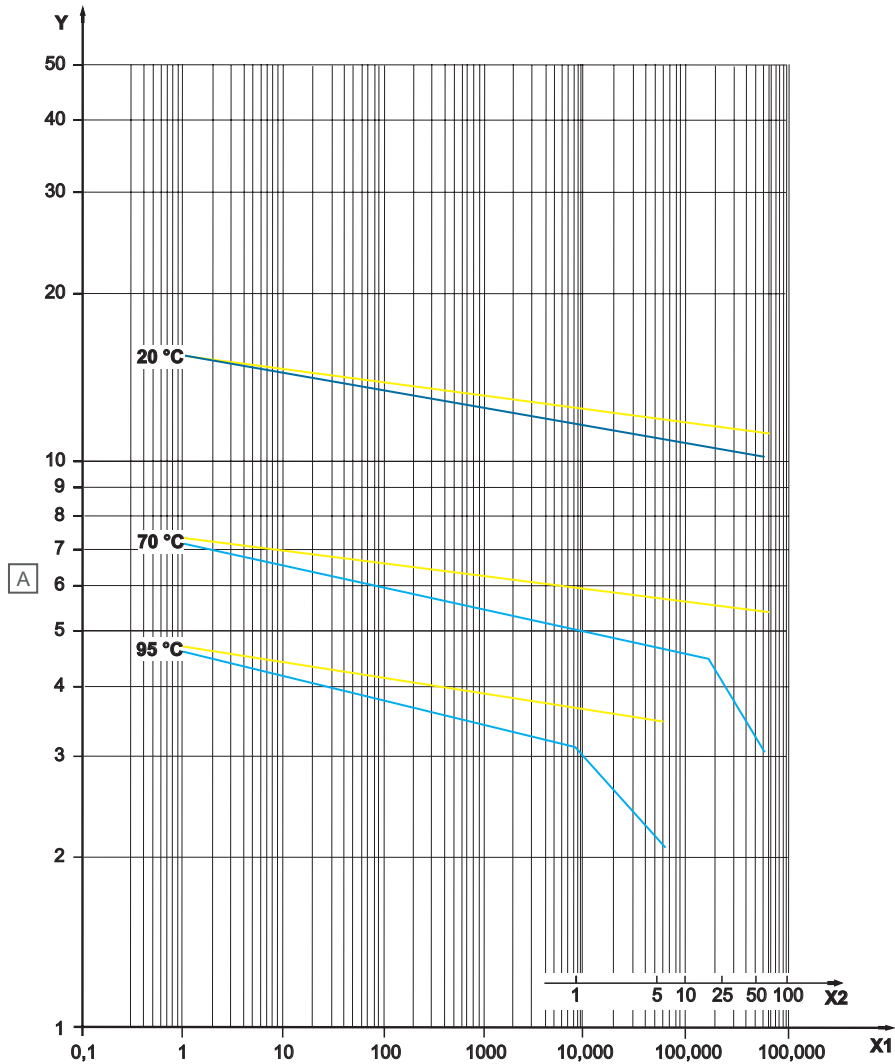

B

Pos.	Unit	Description
A	MPa	Hoop stress
B	h	Time to failure
X2	years	Time to fracture

Item	Description
—	PP-R
—	PP-RCT

The improved long-term strength of the PP-RCT material ensures more economical dimensions of the pipe system. This allows designers to choose thinner-walled pipes, and in some situations smaller diameter pipes can be used.

3.6 Benefit

Aquasystem benefits for installer

Heat fusion

No solder, solvents or adhesives are required for installation. PP-R/RCT is joined by a process known as heat fusion. During the heat fusion process, pipe and fittings to controlled temperatures and then joining them together. Homogeneous connections are easily made. No open flame is required and no toxic volatile organic compounds are released during the process. Heat fusion is fast and safe joining method that can be used.

Compatible piping systems

Aquasystem offers an extended product portfolio of PPR and PP-RCT keeping installation simple.

Reliable piping system

Aquasystem is produced with raw materials that are obtained from 1st quality approved international manufacturers.

Easy to handle

The Aquasystem offers various welding options, such as saddle, electrofusion, or butt fusion welding. This makes it a simple and time-saving solution.

Transport

Due to the low material weight, the pipes and fittings are easy to transport and handle.

Environmental advantages

- Free of toxic substances (BPAs or dioxins)
- Contains no heavy metals
- Longevity (50+ years depending on application)
- 100 % recyclable
- Non-corrosive with low friction factor means less pumping energy is required
- Lightweight (8 times lighter than steel)
- Heat fusion joints providing no-leak systems
- No VOC's are released during production or fusion.
- Traceable system in terms of effect to environment with environmental product declaration

3.7 Tables

Regression curves for PP-R mechanical strength

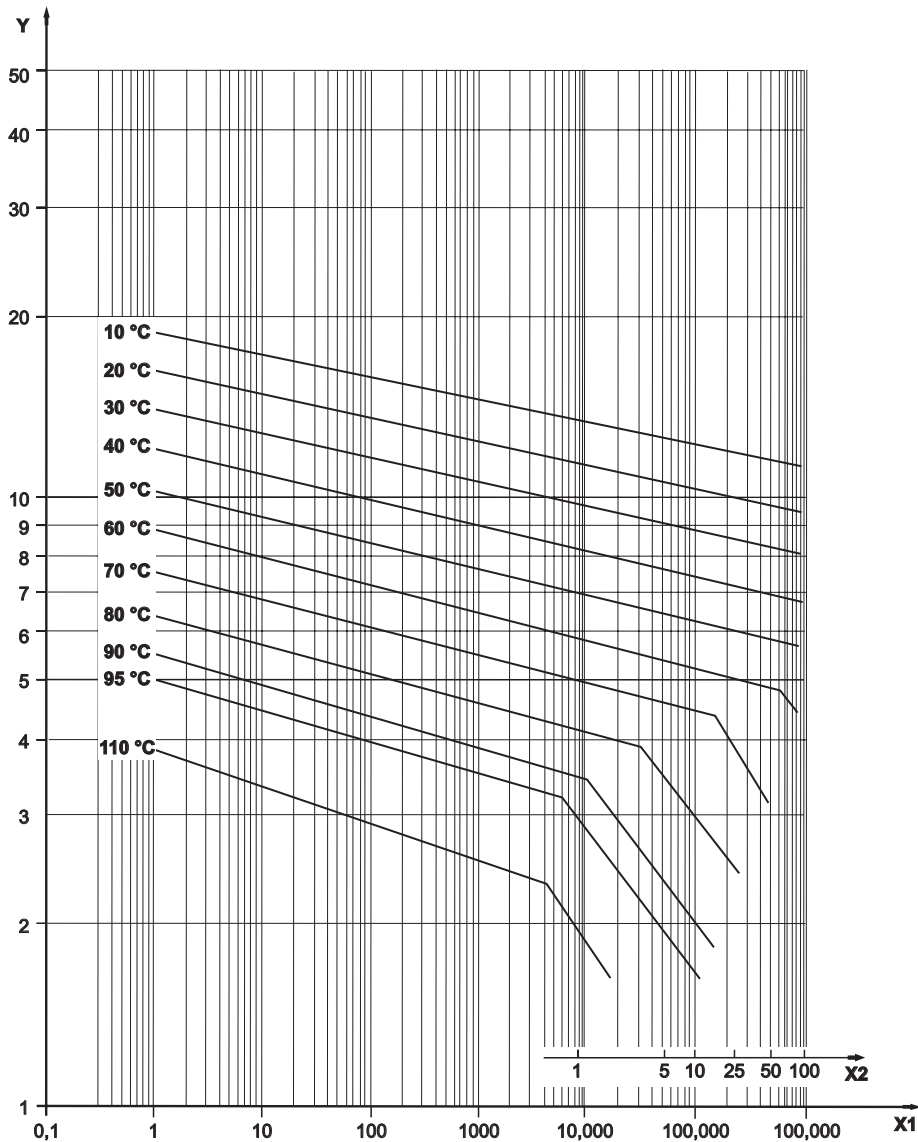

ISO 15874-2:2013(E)

Pos.	Unit	Description
Y	MPa [σ]	Hoop stress
X1	h	Time to fracture t1
X2	year	Time to fracture

Termination of the isotherm indicates maximum service life even at lower tensions. The isotherms depicted in the chart are not extended.

Regression curves for PP-RCT mechanical strength

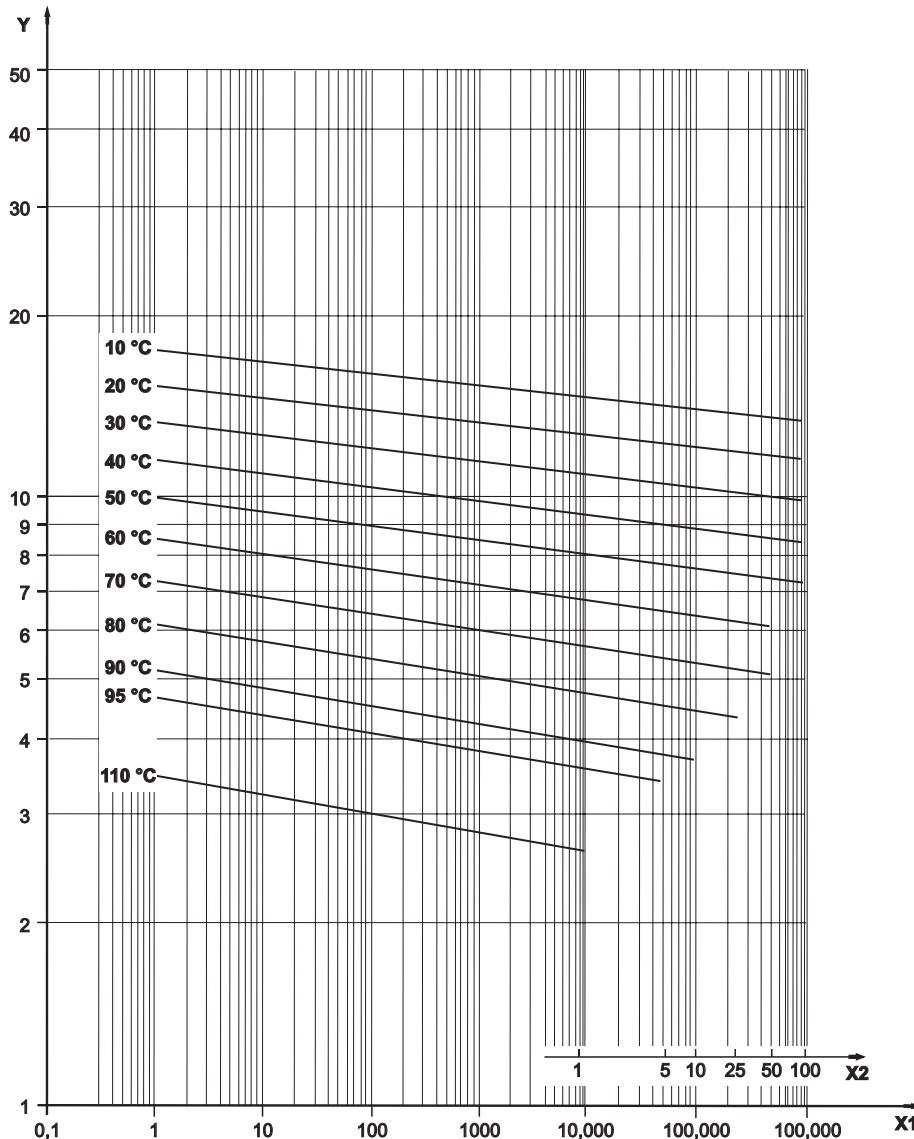

Pos.	Unit	Description
Y	MPa [σ]	Hoop stress
X1	h	Time to fracture t1
X2	year	Time to fracture

Termination of the isotherm indicates maximum service life even at lower tensions. The isotherms depicted in the chart are not extended.

Hydrostatic stress:

expressed in megapascals, induced in the wall of a pipe when a pressure is applied using water as a medium. Using Hydrostatic stress and dimensions, the maximum working pressure can be calculated with the following equation:

$$\sigma = P \times \frac{(d - e)}{10 \times 2e} \times C$$

P = maximum working pressure [bar]

d = outer diameter [mm]

e = wall thickness [mm]

σ = hydrostatic stress [MPa]

C = safety factor coefficient

Classification of service condition according to EN ISO 15874-1

Each class has defined system operating parameters for the total usage period of 50 years. Time when distribution system is exposed to high temperatures (T_{max}) and temperatures during functional failure of the system (T_{mal}) are also included. Pipes are assigned certain maximum operating pressure. When more than one operating temperature applies for a particular class, the periods are summed - refer to service life total.

All pipes compliant with the conditions in the table are suitable for cold water distribution for the period of 50 years at 20 °C and the pressure of 10 bar.

Application class	Service life	Time of operation [years/hour]	Operating temperature [°C]	Typical field of application	PP-R SDR 6	PP-R SDR 7,4	PP-R SDR 11	PP-RCT SDR 7,4	PP-RCT SDR 9
					Maximum operating pressure [bar]				
1	50 years	49 years	60	Hot Water Supply 60 °C	10	8	6	10	8
		1 year	80						
		T _{mal} /service life by T _{mal}	100 hr						
2	50 years	49 years	70	Hot Water Supply 70°C	8	6	4	10	8
		1 year	80						
		T _{mal} /service life by T _{mal}	100 hr						
4	50 years	2,5 years	20	Underfloor heating and low temperature radiators	10	10	-	10	8
		20 years	40						
		25 years	60						
		2,5 years	70						
		T _{mal} /service life by T _{mal}	100 hr						
5	50 years	14 years	20	High temperature radiators	6	6	-	8	6
		25 years	60						
		10 years	80						
		1 year	90						
		T _{mal} /service life by T _{mal}	100 hr						

Example: PP-RCT Pipe SDR 9;

- Class 1/8 bar, 2/8 bar, 4/8 bar, 5/6 bar means that the pipe may be used:
- For distribution of hot water of 60 °C- operating pressure 8 bar, service life of 50 year (class 1/8)
- For distribution of hot water of 70 °C- operating pressure 8 bar, service life of 50 year (class 2/8)
- For underfloor heating and low temperature radiators - operating pressure 8 bar, service life of 50 year (class 4/8)
- For high temperature radiators- operating pressure 6 bar, service life of 50 year (class 5/6)

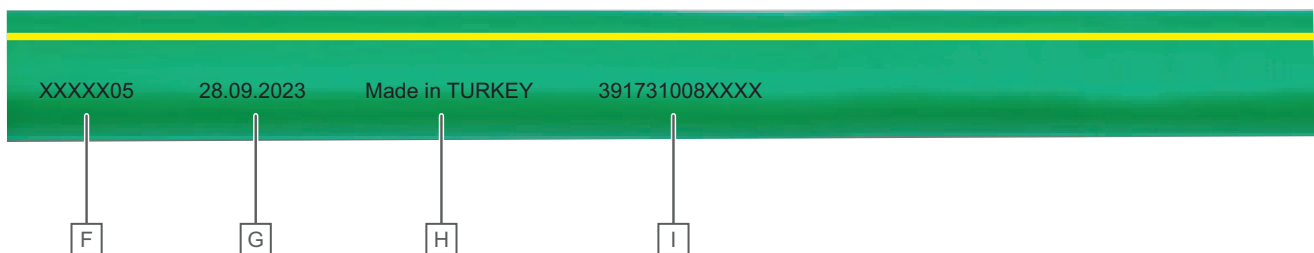
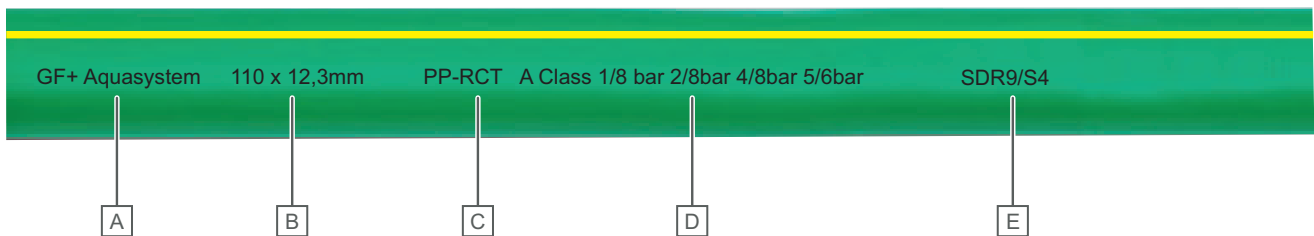

Pos.	Description
A	Brand name
B	Nominal diameter and metric pipe size
C	Material description
D	Class of application
E	Standard dimensions ratio Series
F	Extrusion no
G	Production date
H	Production origin
I	EAN code

Temperature, pressure and service life tables

According to DIN 8077 standard

Maximum operating pressures according to DIN 8077 with safety factor of 1,5						
Operating temperature [°C]	Service life in years	PP-R			PP-RCT	
		SDR 11 [S 5]	SDR 7,4 [S 3,2]	SDR 6 [S 2,5]	SDR 9 [S 4]	SDR 7,4 [S 3,2]
10 ¹⁾	1	17,6	27,8	35	24	30,2
	5	16,7	26,3	33,2	23,2	29,3
	10	16,1	25,6	32,1	22,9	28,9
	25	15,6	24,8	31,1	22,5	28,4
	50	15,2	24,1	30,3	22,2	28
20 ¹⁾	1	15	23,8	30	20,9	26,3
	5	14,1	22,3	28,2	19,9	25,4
	10	13,7	21,8	27,3	19,6	25,1
	25	13,3	21	26,5	19,3	24,6
	50	12,9	20,4	25,8	18,1	24,3
30	1	12,8	20,2	25,5	17,4	22,7
	5	12	18,9	23,9	17,2	22
	10	11,6	18,4	23,1	16,9	21,7
	25	11,2	17,8	22,3	16,6	21,2
	50	10,9	17,3	21,8	15,5	20,9
40	1	10,8	17,2	21,5	15	19,6
	5	10,1	16	20,2	14,7	18,9
	10	9,8	15,6	19,7	14,4	18,6
	25	9,4	15	18,8	14,2	18,2
	50	9,2	14,5	18,3	14,2	17,9
50	1	9,2	14,5	18,3	13,3	16,7
	5	8,5	13,5	17	12,8	16,1
	10	8,3	13,1	16,4	12,6	15,8
	25	8	12,6	15,9	12,3	15,5
	50	7,8	12,3	15,4	12,1	15,2
60	1	7,8	12,3	15,4	11,2	14,2
	5	7,2	11,3	14,3	10,8	13,6
	10	6,9	11	13,8	10,6	13,4
	25	6,7	10,6	13,3	10,4	13,1
	50	6,4	10,3	12,8	10,2	12,8
70	1	6,5	10,3	13	9,4	11,9
	5	6	9,5	11,9	9,1	11,4
	10	5,8	9,3	11,7	8,9	11,2
	25	5,1	8	10,1	8,7	10,9
	50	4,3	6,8	8,5	8,5	10,7
80	1	5,4	8,6	10,9	7,9	9,9
	5	4,8	7,6	9,6	7,5	9,5
	10	4	6,4	8,8	7,4	9,3
	25	3,2	5,2	6,3	7,2	9,1
95	1	3,8	6,1	7,7	5,9	7,4
	5	2,5	4,1	5,1	5,6	7,1
	10	2,2	3,4	4,3	5,5	6,9

* Cold water applications

Chemical disinfection

Note

Recommendations for the disinfection of GF piping systems for building technology:

For more information refer to chapter "Recommendation for the disinfection of GF building technology products".

Note

Principles for a safe chemical disinfection

- Before the disinfection measure, proceed with a cleaning flush.
- The disinfectants used must be approved for the drinking water installation.
- Only use cold water for disinfecting purposes. Hot pipe parts must be cooled to a cold water temperature level.
- The disinfectant must reach all parts of the pipeline.

The disinfectant must drain at the taps until the intended concentration has been confirmed by appropriate measurements.

Chemical disinfectants are used for cold and hot water pipes as well as for the disinfection of large surfaces (e.g. drinking water heaters). If the risk analysis verifies that the thermal disinfection process does not allow for effective remedy and the drinking water installation is contaminated with biofilm, a chemical disinfection procedure may be considered.

Depending on the type of microbial contamination, the most effective disinfectant must be chosen, taking into account the different materials used in the installation. The most common chemical disinfectants are sodium hypochlorite and chlorine dioxide.

However, chemical substances must not be present in drinking water to the extent where the concentrations are harmful to human health. If drinking water installations are disinfected, the concentration of chemical substances must be kept as low as is possible under the generally accepted rules of technology (with reasonable effort and taking into account individual cases).

Continuous dosing with disinfectant chemicals should be avoided wherever possible. Preventive chemical disinfection does not make sense unless microorganism contamination has been identified on the basis of a risk analysis.

The basic prerequisite for a successful disinfection is always cleaning of the whole drinking water installation before the procedure. When repairing microbially heavily contaminated systems, it is recommended to carry out an intermittent flushing with an air/water mixture before the disinfection measure. The aim of this flushing process is to mechanically detach and remove biofilms and dirt.

The permissible, necessary concentrations and reaction times of the chemical disinfectants are specified in the drinking water ordinance of the respective country.

Implementation

- The disinfection procedures must be performed outside normal business hours.
- Make sure that the materials used in the installation are suitable for the intended disinfectant. If in doubt, call the manufacturer.
- Quantity proportional addition: Adjust the dosing pump to the appropriate stroke according to the intended concentration.
- Open the pipe sections that must be disinfected one by one, starting at the nearest tap to the tap at farthest point.
- Activate all pipeline fittings during the disinfection procedure.

After process is completed, compliance with the following instruction is mandatory:

- The disinfectant used must still be detectable at the end of the exposure time.
- The drinking water installation must be flushed and all chemicals must be removed.
- The conditions under which the sewer system operator accepts the disinfectant to enter into the sewer system must be taken into account when discharging the disinfectants into the public sewage system.
- During disinfection and after flushing out all taps: Create a measurement protocol about the concentrations.
- Put the system back into operating condition.
- Check to ensure that the performed disinfection measure was correct.

Recommendation for the disinfection of GF building technology products

Note

Recommendations for drinking water installation systems and product groups

Based on many years of experience, the recommendations in this chapter can be made for the following drinking water installation systems and product groups:

- JRG Sanipex, JRG Sanipex MT, JRG Armaturen, iLITE, iFIT, INSTAFLEX and Aquasystem.

Note

Based on many years of experience, in cases where a chemical disinfection is unavoidable, we recommend the use of a sodium hypochlorite disinfectant solution.

Disinfection can pollute and damage the materials and components of the drinking water installation. In order to ensure the success of a disinfection procedure and not to interfere with the materials coming in contact with the drinking water, compliance with the object-specific clarifications described in the chapter "Disinfection" (Preparations for performing a disinfection) is mandatory.

The selection of the disinfection process takes place in each case object-specifically and primarily according to the suitability for the materials that come in contact with the drinking water. The common chemical disinfectants in drinking water such as sodium hypochlorite, chlorine dioxide as well as the thermal disinfection are described. Other disinfection procedures and deviations from the conditions described (e.g. increased concentrations of disinfectants or elevated temperatures) should be discussed with your GF Building Flow solutions representative.

The following list contains references for the material resistance of the GF Building Flow solutions for building technology. By complying to these conditions, as a rule, the service life is not expected to be shortened. Restrictions can result from the drinking water ingredients as well as the indicator parameters (pH value, conductivity, etc.). Likewise, compliance with the national laws and regulations on the disinfection of drinking water, in particular limit values, is mandatory. The specified limits are based on the state-of-the-art technology used in Germany.

Recommendation for disinfection

Parameters	Disinfectant	Concentration [mg/l]	Temperature [°C]	Duration [h]
Continuous disinfection	Sodium hypochlorite	maximum 0,3	≤ 70	-
Shock disinfection (maximum 2 x per year)	(free chlorine)	maximum 50	≤ 30	≤ 24

Thermal disinfection

When using thermal disinfection, it is recommended to raise the temperature to 70 °C for at least 3 minutes. As a rule, this temperature increase has no negative effects on the GF building technology products. Compliance with the applicable rules when using thermal disinfection is mandatory.

Sodium hypochlorite (NaClO)

Note

Explanation of terms

- **Free chlorine** (oxidative form): sum of the mass concentration of elemental dissolved chlorine (Cl₂), hypochlorous acid (HClO) and hypochlorite (ClO⁻), expressed in mg/L.
- **Bound chlorine** (already reacted form): Mass concentration of inorganic and organic chloramines, calculated as chlorine in mg/L.
- **Total chlorine**: The sum of mass concentrations of free and bound chlorine in mg/l.

When using **continuous disinfection** with sodium hypochlorite, the concentration of 0,3 mg/l free chlorine and a maximum temperature of + 70 °C must not be exceeded.

A **discontinuous disinfection** (shock disinfection) may be carried out twice a year, using a concentration of free chlorine of maximum 50 mg/l over a period of 24 h. During the shock disinfection, the drinking water temperature of 30 °C must not be exceeded. A subsequent, thorough flushing of the whole drinking water installation is most important.

Chlorine dioxide

The use of chlorine dioxide for the chemical disinfection of drinking water is not recommended because it attacks the materials due to its strong oxidizing power and thus significantly shortens the lifetime of the entire drinking water installation. Take special care with the use of chlorine dioxide in hot water, a massive impact on the lifetime is expected. If chlorine dioxide is still used, the conditions on site must be precisely recorded and discussed with your GF Building Flow solutions representative.

Pressure loss

The pressure losses for distribution in the GF Piping Systems can be assessed by means of the following chart or by means of the following formula:

$$\Delta p = \Lambda \cdot \frac{L \cdot \rho \cdot V^2}{d_i \cdot 2 \cdot 10}$$

Where:

Δp pressure loss in a straight pipe [bar]

Λ A pipe friction factor (in most cases 0,02 is sufficient)

L length of straight pipe [m]

ρ density of transported media [kg/m³]

V flow velocity [m/s]

d_i inside diameter of pipe [mm]

PN20/PN28 pipe

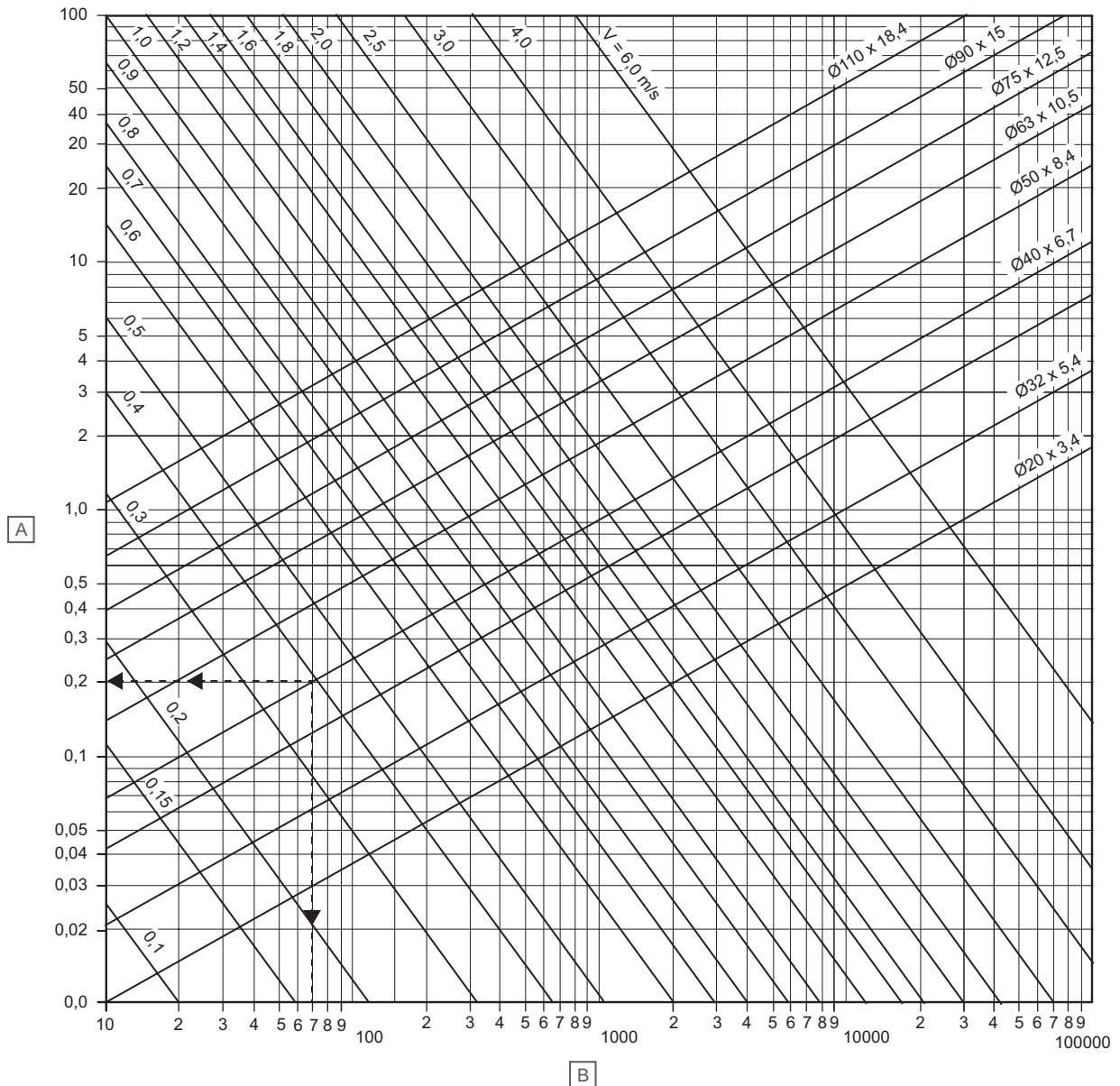

Pos.	Unit	Description
A	l/sec	Flow
B	Pa/m	Pressure loss

Example:

Pipe: 40 x 6,7 mm

Flow: 0,21/s

Water velocity: 0,4 m/s

From the diagram,

Pressure loss

= 70 Pa/m

= 0,7 mbar

(10,000 Pa = 0,1 bar = 100 mbar)

PN10/PN14 pipe

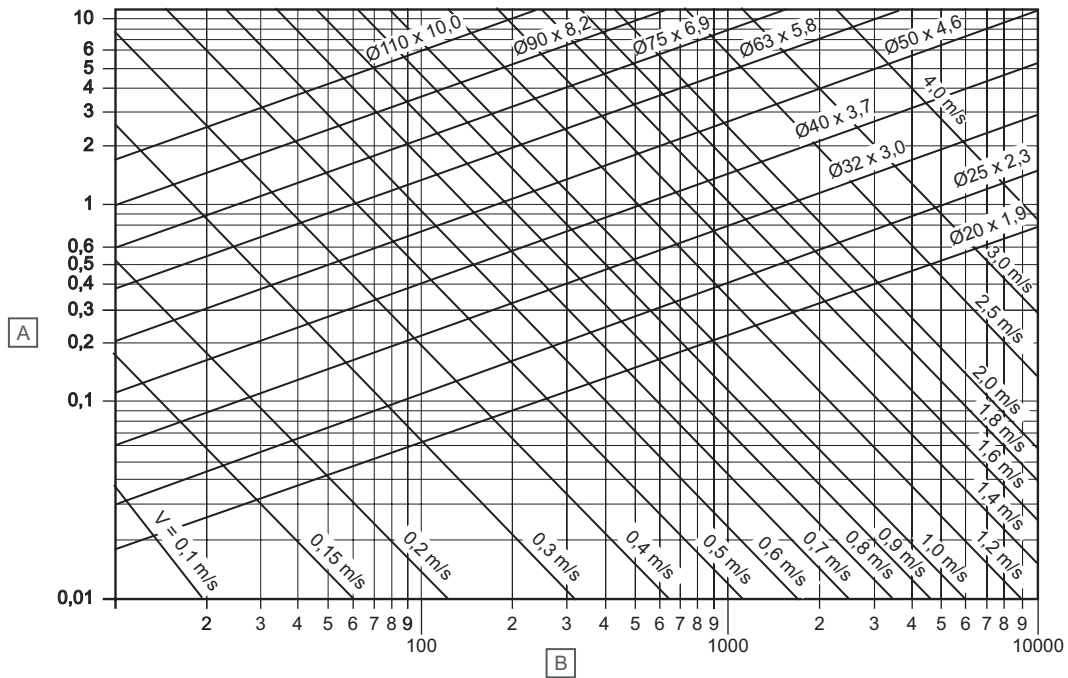

Pos.	Unit	Description
A	l/sec	Flow
B	Pa/m	Pressure loss

Description	Symbol	Coefficient of resistance
-------------	--------	---------------------------

Concentric reductions up to 3 size		0,85
Threaded fitting, male		0,40
Threaded fitting, male, reduced		0,85
Threaded elbow, male		2,80
Threaded elbow, male, reduced		3,50

Pressure loss in GF fittings

Description	Symbol	Coefficient of resistance
Equal coupling		0,25
Elbow 90°		2,00
Elbow 45°		0,60
Equal tee 90°		1,80
Reduced tee 90°		3,60
Equal tee 90°		1,30
Reduce tee 90°		2,60
Equal tee 90°		4,20
Reduced tee 90°		9,00
Equal tee 90°		2,20
Reduce tee 90°		5,00
Threaded tee 90°, male		0,80
Concentric reductions up to 2 sizes		0,55

Example

Assume we have a water services system with the following characteristics:

- pipe diameter 25 mm
- total pipe length 10 m
- fittings used:
 - 4 coupling
 - 3 elbows 90°
 - 2 equal tees
 - 1 threaded coupling, male
- velocity 1,5 m/s
- flow rate 0,35 l/s
- T = 20 °C

From the table

§ 1 (coupling) = 0,25 x 4

§ 2 (elbow 90°) = 2,00 x 2

§ 3 (equal tees) = 1,80 x 2

§ 4 (threaded coupling male) = 0,40 x 1

total § = 11

$$\text{Total P} = \Delta p + H$$

From above graph

$$\Delta p = 1100 \text{ Pa/m}$$

$$= 11 \text{ mbar}$$

For 10 m length pipe,

$$\Delta p = 11 \times 10$$

$$= 110 \text{ mbar}$$

$$\text{Total P} = H + \Delta p$$

$$= 110 + 126$$

$$= 236 \text{ mbar}$$

$$H = 10 \cdot \frac{\xi_1 \cdot v^2 \cdot \rho}{2g}$$

Where:

H = pressure losses in fittings

v = water velocity [m/s]

g = specific gravity of water [kg/m³]

$$= 9,8 \text{ [m/s}^2\text{]}$$

\xi_1 = coefficient of resistance

$$H = \frac{10 \times 11 \times 1,5^2 \times 1000}{2 \times 9,8}$$

$$= 12630 \text{ Pa}$$

$$= 126 \text{ mbar}$$

Ring stiffness of Aquasystem pipes

Aquasystem polypropylene pipes have a ring stiffness of $\geq 16 \text{ kN/m}^2$ (according to DIN EN ISO 9969) and therefore can be classified in the ring stiffness class SN16.

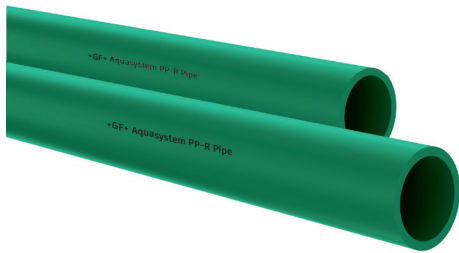

4 Installation

4.1 General precautions

	<p>Caution!</p> <p>In cold weather, in particular at temperatures below 0 °C, take extra care when handling the pipe. Cold temperatures reduce the pipe's flexibility, making it more susceptible to impact damage</p>
-----------------------------------------------------------------------------------	-------------------------------------------------------------------------------------------------------------------------------------------------------------------------------------------------------------------------------

	<p>Note</p> <p>Ensure the part is properly installed to the system when using the ball valve for the first time. Noticeably more effort may be required due to the production process and only occurs on the first use. This is not a fault. Basically, a ball valve should be operated several times a year (2-4 times) to ensure proper functioning.</p>
-----------------------------------------------------------------------------------	-------------------------------------------------------------------------------------------------------------------------------------------------------------------------------------------------------------------------------------------------------------------------------------------------------------------------------------------------------------------

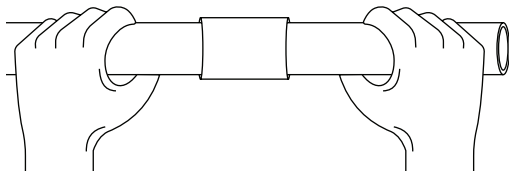

The products to be used in the installation must be undamaged and uncontaminated during storage and transportation. It is difficult to provide suitable working conditions at low temperature for perfectly assembled pipe system.

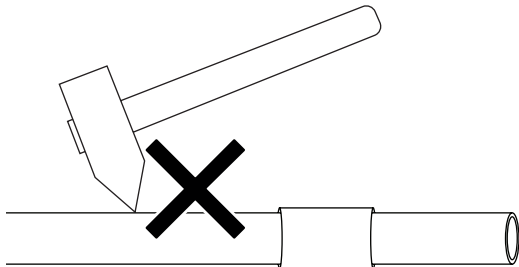

Parts of plastic piping systems must be protected against damage during transport and installation.

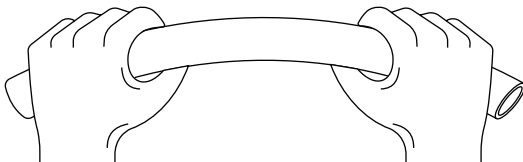

Pipe bending should be done at + 15 °C and above. For pipes of diameter range 16 - 32 mm a minimum bending radius equals to eight diameters [D].

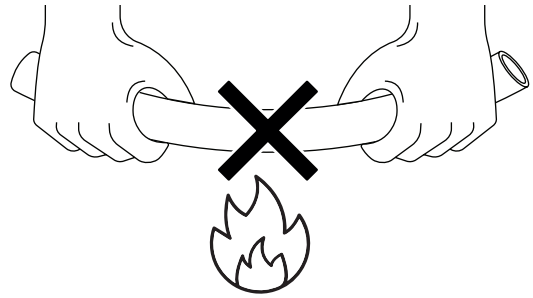

Parts must not be exposed to naked flames.

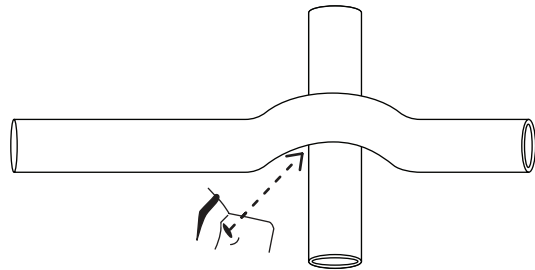

Pipeline cross-overs should be made with parts designed clearly for this purpose.

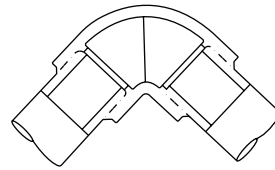

Three welding processes are used in the drinking water installation in order to connect the pipes and moulded parts made of thermoplastics. Socket fusion, electrofusion and butt fusion welding. The fusion process should be carried out in accordance with the instructions and with appropriate equipment in order to get high quality results.

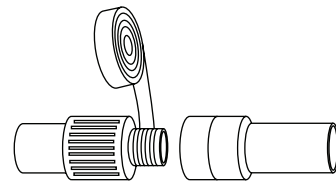

Threaded fittings must be used for screw type joints. Threads should never be cut directly into plastic components. Threads are sealed with a special PTFE tape or sealing compounds. Don't use flax.

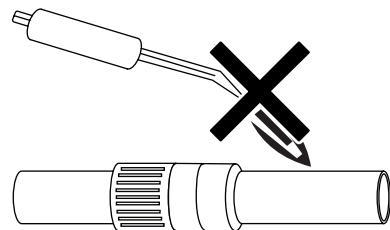

Soldering or brazing of metal fittings should not be done near the joint between metal and plastic systems, as this can cause heat transfer to the fitting.

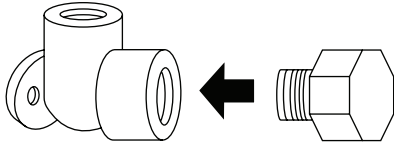

It is recommended to use plastic plugs for blanking elbows or wall mounting groups (plastic plugs are designated only for temporary use). Long term blanking requires using plugs with metal thread.

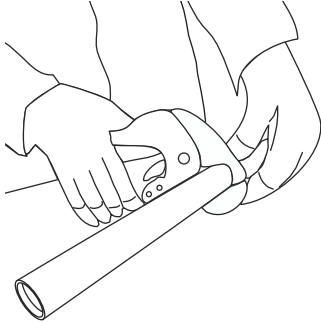

Use plastic pipe cutter always handle the ends of the pipe carefully. If the pipe is exposed to impact or stress, inspect it for damage. Damaged ends or sections should be marked and removed before installation. Surface scratches deeper than 10 % of the wall thickness are considered damage.

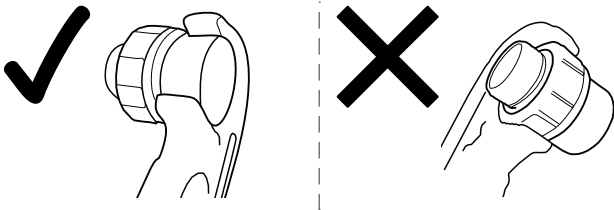

Tighten the parts as shown in above the image. Don't do squeezing in plastic side, do from metallic part side. Don't apply force more than 60 N while applying the pipe wrench.

4.2 Jointing technology

In the field of plastic piping system construction, the following jointing technologies are predominantly used for the application of drinking water pipes, cold and hot:

- Thread connection
- Mechanical connection
 - Crosslinked polyethylene (VPE, PB, PE, ML, PP)
- Push-fits
- Crimped connections
- Welded joint (polyolefin materials)
 - Polyethylene (PE)
 - Polybutene (PB)
 - Polypropylene (PP)
- Adhesive bond (vinyl chloride materials)
 - Polyvinyl chloride (PVC)
 - Post-chlorinated polyvinyl chloride (PVC-C)
- Flange connection

Overview of connection types

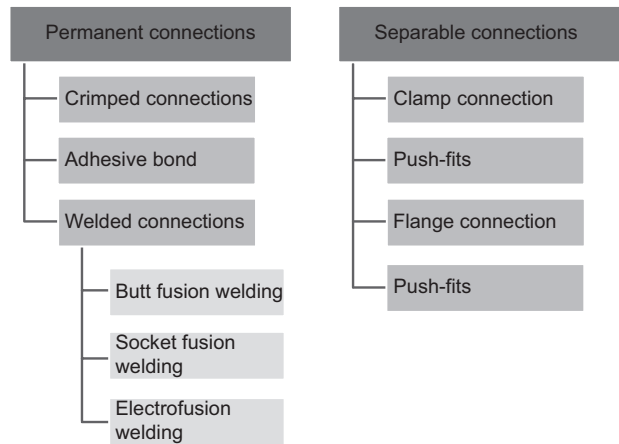

Welded connections

When using fusion connections in the piping system construction, only polyolefin thermoplastics must be used:

- Polybutene (PB)
- Polyethylene (PE)
- Polypropylene (PP)

Overview

A weld in the plastic sector is a cohesive connection of two similar materials, that is to say, it is a direct joint of two parts of the same material without the addition of compounding agents, as they are used for example when gluing is needed.

Welding joints are permitted, for example, when jointing PB and PB pipes. Welding joints are not permitted, for example, when jointing PP and PE pipes

Each weld joint depends on three factors that affect the welding process:

- Temperature
- Time
- Jointing pressure

The optimal interaction of these three factors creates a welded joint between two similar plastic materials. This joint achieves its full strength after cooling.









Quality criteria

The quality criteria of a welded joint relate to the above-mentioned factors temperature, time and pressure.

Aquasystem heat fusion

Precautions

	Caution!
	Always take occupational safety measures.

Item	Description
	Wear suitable work clothing
	Wear safety shoes
	Wear hearing protection
	Wear a safety helmet
	Wear safety glasses
	Improper use can cause severe cuts, bruising or dismemberment
	Take proper precautions around electrical equipment and follow all instructions
	Be careful when handling hot irons

- Before operating the fusion machines, make sure that the working area is safe.
- All welding tools must be free from impurities. Make sure they are clean and dry before assembling.
- Improper use of tools can damage components and cause leaks.
- Always read and follow the operating instructions of the tool being used.
- While working with the welding machine, wear appropriate hand and arm protective gloves to avoid the risk of burning.
- Wearing protection goggles are also recommended.
- During the operation, always beware of the position of the machine. Make sure that welding plates are tightly fitted and not loose.
- Pipes must be cut perpendicular to the axis with suitable plastic pipe cutting tools. Always ensure that cutters are sharp. Cutting pipes with dull or damaged ratchet cutters can cause the pipe to crack. Only use the plastic pipe cutters to cut PP-R material.
- Pull out the power plug for maintenance or relocation activities and protect it against unintentional switching on.
- Pipes, fittings and joints when operating parameters are exceeded is overloaded. Exceeding the operating parameters is therefore not possible allowed. Ensure compliance with operating parameters with safety.

Socket fusion welding

Aquasystem socket fusion of d16 mm - d160 mm

The basics

Aquasystem fittings and pipes comply with the international standards and requirements. Aquasystem PP-R pipes and fitting are made of the same polypropylene random co-polymer material and Aquasystem PP-RCT pipes are made of polypropylene-random-copolymer enhanced crystalline structure improved temperature resistance material. Aquasystem PP-RCT pipes and Aquasystem PP-R fittings are also fully compatible and weldable so a homogenous fusion joint is formed.

Heating-element socket fusion

In socket fusion the pipe and the fitting overlap and are fused without the use of auxiliary materials. Pipe ends and fitting sockets are heated with the help of a socket or spigot-shaped heating element to a specific fusion temperature and then joined. The pipe, socket and heating element are dimensioned so that a fusion pressure is built up during the fusion process. The fusion temperature is $260 \pm 10 \text{ }^\circ\text{C}$ ($250 \text{ }^\circ\text{C} - 270 \text{ }^\circ\text{C}$).

Tools required

In addition to the plastic pipe cutter, a pipe sharpener tool for Al layered pipe and peeling tools for UV pipes are required for fusion prepping. For socket fusion an electrically heated and hand-held fusion device and/or a fusion machine are necessary. Provided that the equipment, machines, heating bushes and spigots conform to DVS Guideline 2208, fusion may be performed with any commercially available tools

Process and control

1. Clean the heating element, moulded part and pipe end.
2. Warm up the moulded part and pipe.
3. Jointing, holding in place and cooling.
4. Inspecting the weld seam.

Fusion sequence

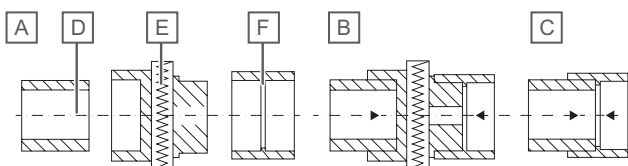

Pos.	Description
A	Details
B	Jointing, holding, in place and cooling
C	Finished joint
D	Pipe
E	Heating element (Including heating spigot and heating bush)
F	Fitting

Weld seam inspection

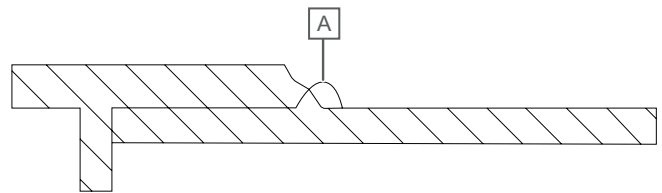

Pos.	Description
A	Fusion bead

A fusion bead shown in above image that is as uniform as possible must be present along the entire circumference of the fusion zone.

Socket fusion machines

Hand-held fusion device



Bench type fusion machine

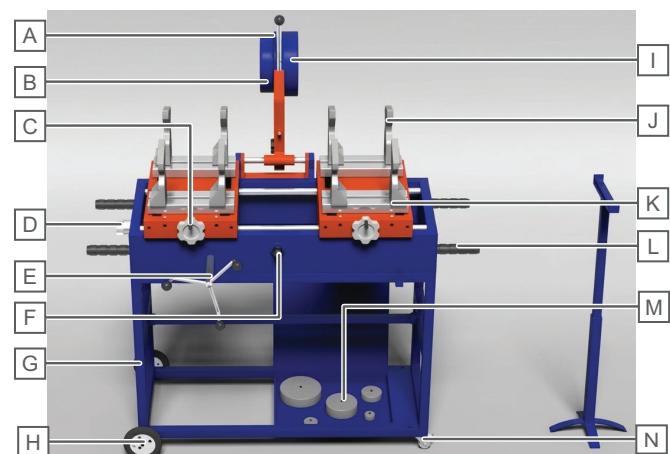

Pos.	Description
A	Heater
B	Socket
C	Hand wheels for locking unlocking pipe
D	Diameter selector
E	Hand wheels for carriages movement
F	Knob for pipe position
G	Machine body trolley
H	Stand transport wheel
I	Lever for heating movement
J	Jaw
K	Jaw locking lever
L	Handle for lifting
M	Tool bag sockets
N	Break wheel

The use of a bench-mounted fusion machine has proved highly advantageous in terms of ease of use. Welding range is 50 mm to 160 mm. Easy handling and a special pick-up for fittings enable stress-free fusion, making this machine a valuable aid in the fusion process.

Fusion preparation

Note
Operator should use protective equipment.

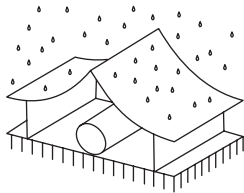

Protect the fusion equipment and the work area from dampness and dirt. While working with the welding machine, wear appropriate hand and arm protective gloves to avoid the risk of burning. Wearing protection goggles are also recommended. During the operation, always beware of the position of the machine. Make sure that welding plates are tightly fitted and not loose. Always take occupational safety measures.

Set machine and equipment

Welding heads should be placed on the welding machine so that the parts do not move or rare not turned.

Plug the welding machine in a 220 volt standard outlet.

Periodic temperature check

Note
Tempilstik pens are ancillary equipment to make sure you are within the given temperature range of welding.

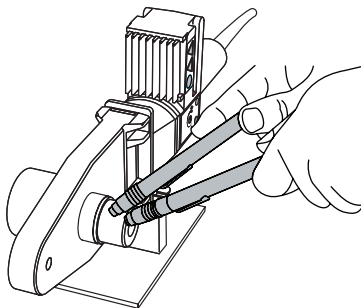

Set the fusion temperature of the heating element at 260 °C. Push the power button. Heating will take 1 to 3 minutes. When temperature reaches 260 °C, thermostat light will switch off automatically. The temperature required for socket fusion with Aquasystem is between 250 °C and 270 °C. You can check the fusion temperature on the outside of the heating bush with temperature indicating sticks. This temperature check should be repeated periodically, especially if the weather conditions are adverse.

The correct temperature of the heating element has been reached when the 253 °C stick melts on the outside of the heating bush and the 274 °C stick does not melt.

Cleaning the heating socket and spigot

Warning!
Damaged or worn heating bushes can lead to faulty fusion. Replace damaged heating bushes.

Caution!
Hot can cause burns. The heating tools are heated to 270 °C

Make sure heating bush and heating spigot are clean before welding. Clean the heating bush and heating spigot after each fusion with a clean, dry, lint-free paper without a cleanser.

Cut the pipe

Warning!
If you're working with the external layered Al pipe (Super Stable), make sure the remove the outer PP-R and Al-layers first, using a special sharpener tool along the whole pipe section to be inserted into the socket.

Caution!
If you're working with the UV layered pipes, make sure the peel of UV layers first, using a special peeling tool along the whole pipe section to be inserted into the socket.

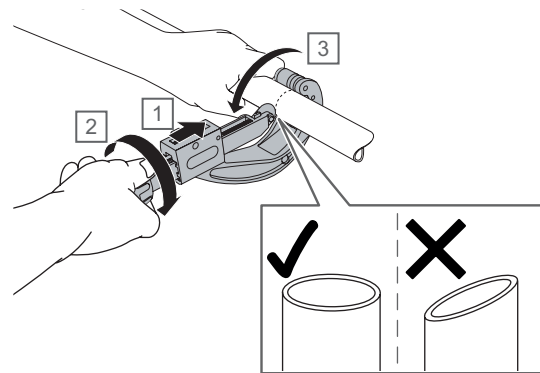

Cut the pipe squarely to length as shown in above image.

Cleaning the heating socket and spigot

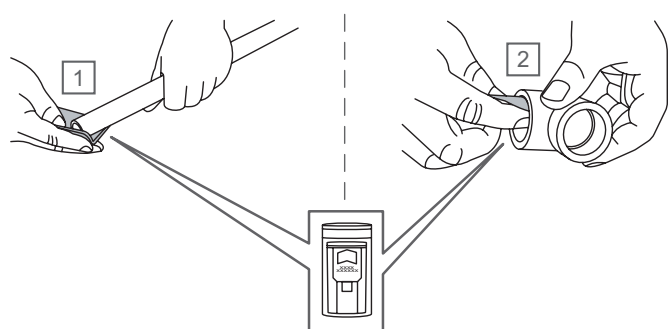

Clean the jointing surfaces of the parts to be joined - fitting and pipe end - immediately before beginning with the fusion. Use an absorbent, lint-free paper and the cleaning fluid Tangit KS cleaner. Wipe off the cleaning fluid completely with cleaning paper.

Mark the insertion depth

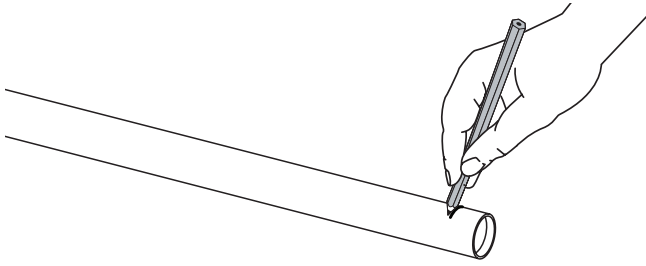

Mark the insertion and joining depth according to the pipe. Make sure the mark stays visible when heating and joining.

Heat soak the pipe end and socket fitting

Note
Pipe marking should be visible after joining pipe and fittings.

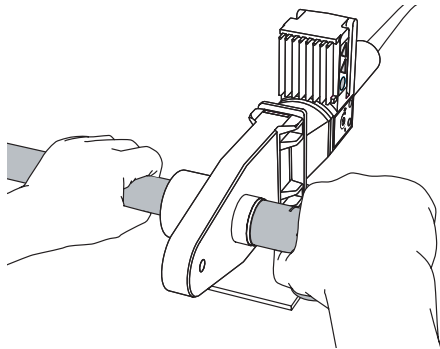

Slide the pipe end and fitting onto the heating socket or spigot without twisting and not too quickly. (Material melts slowly). The heat soak time begins when the pipe and fitting are completely inserted in the heating socket or on the heating spigot. After the heat soak period, pull the fitting and pipe slowly off the heating tools and without twisting or turning.

Joining the pipe and fitting

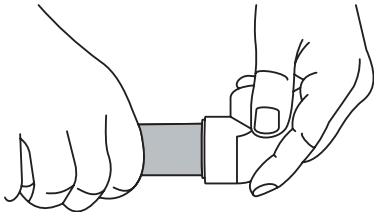

Join the fitting and the pipe immediately after heat soaking and without axial rotation. The holding and cooling times must be observed. Do not twist the parts during and after joining.

Cooling time

After the pipe and fitting joined, joined parts (fitting and pipe) must be held securely without twisting or turning. The fused parts (fitting and pipe) may only be subjected to further installation loads when the cooling time has elapsed.

Fusion parameters

Note
Heating time to be increased by 50 % for ambient temperatures below + 5 °C

Note
Please make sure the peel off "UV layer pipe" (peel UV layer) and "external-Al layered (super stable) pipes (peel Al layer)" using a special peeling tool along the whole pipe section to be inserted into socket before socket welding.

Pipe diameter [mm]	Welding depth [mm]	Heating time [sec]	Welding time [sec]	Cooling time [minute]
20	14,5	5	4	2
25	16	7	4	2
32	18	8	6	4
40	20,5	12	6	4
50	23,5	18	6	4
63	27,5	24	8	6
75	30	30	8	6
90	33	40	8	8
110	37	50	10	8
125	40	60	10	8
160	48	90	12	10

PP-RCT pipes are fully compatible and weldable with our PP-R fittings

- Same tooling/equipments
- Same welding parameters
- Same assembling instructions

Fusion check

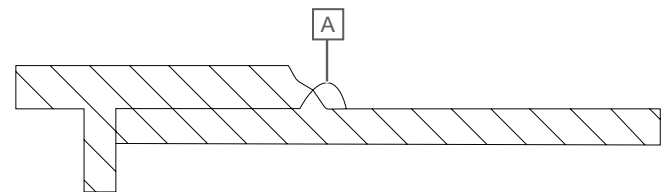
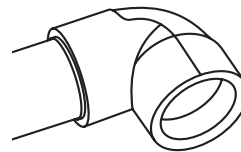

Pos.	Description
A	Fusion bead

Check the outer bead of the fusion weld. The fusion bead must go around the entire circumference, as shown in above image.

Pressure test

All the fusion joints must be completely cooled before beginning with the pressure test.

Saddle socket fusion welding

In saddle fusion, branches and outlets can be easily mounted to the pipe wall using a technique similar to socket fusion.

Fusion preparation

	<p>Note Operator should use protective equipment.</p>
--	------------------------------------------------------------------

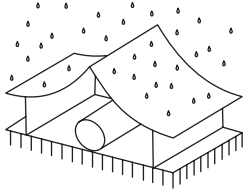

Protect the fusion equipment and the work area from dampness and dirt. While working with the welding machine, wear appropriate hand and arm protective gloves to avoid the risk of burning. Wearing protection goggles are also recommended. During the operation, always beware of the position of the machine. Make sure that welding plates are tightly fitted and not loose. Always take occupational safety measures.

Set machine and equipment

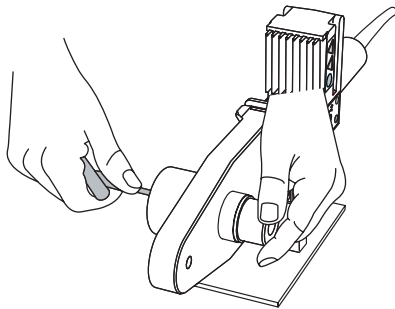

Welding heads should be placed on the welding machine so that the parts do not move or rare not turned.

Plug the welding machine in a 220 volt standard outlet.

Cleaning the heating socket and spigot

	<p>Warning! Damaged or worn heating bushes can lead to faulty fusion. Replace damaged heating bushes.</p>
--	----------------------------------------------------------------------------------------------------------------------

Make sure heating bush and heating spigot are clean before welding. Clean the heating bush and heating spigot after each fusion with a clean, dry, lint-free paper without a cleanser.

Periodic temperature check

	<p>Caution! Hot can cause burns. The heating tools are heated to 270 °C</p>
--	----------------------------------------------------------------------------------------

	<p>Note Tempilstik pens are ancillary equipment to make sure you are within the given temperature range of welding.</p>
--	------------------------------------------------------------------------------------------------------------------------------------

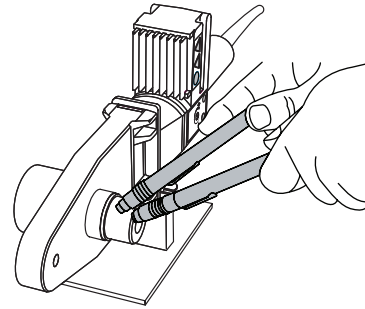

Set the fusion temperature of the heating element at 260 °C. Push the power button. Heating will take 1 to 3 minutes. When temperature reaches 260 °C, thermostat light will switch off automatically. The temperature required for socket fusion with Aquasystem is between 250 °C and 270 °C. You can check the fusion temperature on the outside of the heating bush with temperature indicating sticks. This temperature check should be repeated periodically, especially if the weather conditions are adverse.

The correct temperature of the heating element has been reached when the 253 °C stick melts on the outside of the heating bush and the 274 °C stick does not melt.

Mark the drilling position

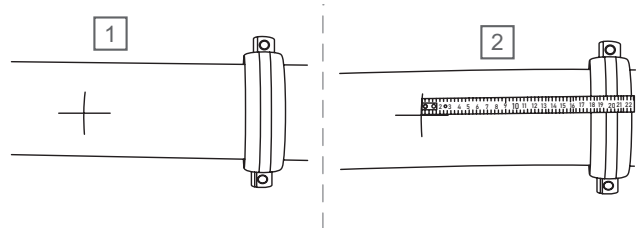

Mark the pipe where you want the outlet. Once you begin drilling you cannot move the hole, so be sure of your placement. Mount a pipe bracket about 15 to 20 cm next to the drilling point to prevent the pipe from bending out during assembly

Drill the pipe

	<p>Note The hole must be drilled at a right angle.</p>
--	-------------------------------------------------------------------

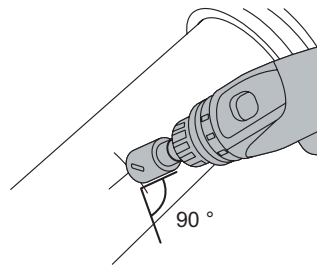

Use the guide bit to start the hole and ensure accurate positioning. Drill at a right angle to the pipe. Use a speed-controlled drill with 300-350 rpm. Quickly drill out the hole.

Chamfer the hole

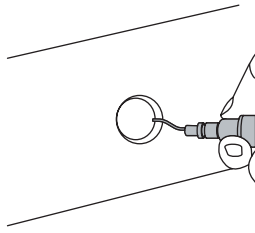

The bore should pull the shavings out so they don't fall into the pipe. Clear away any excess debris.

Chamfer 3 to 4 mm of the drill hole, which makes it easier to insert the heating bush in the next step.

Clean the pipe, bore hole and fitting

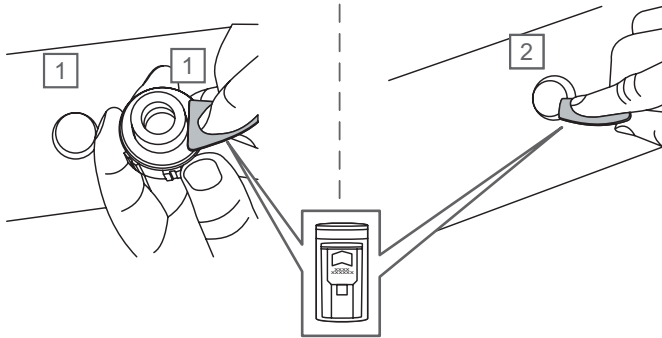

Clean the jointing surfaces of the parts to be joined - fitting and pipe end - immediately before beginning with the fusion. Use an absorbent, lint-free paper and the cleaning fluid Tangit KS cleaner. Wipe off the cleaning fluid completely with cleaning paper.

Welding the weld saddle



Note

Do not forget to clean the heating bushes after welding. Do cleaning of parts after unplugging the machine and making sure that all parts are completely cool.



Note

Only the UV layer of the Aquasystem pipe UV must be removed with special peeling drills.

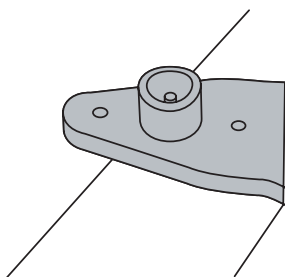

Insert the heating tool on the concave side of the weld-in saddle tool into the hole drilled in the pipe wall until the tool is completely in contact with the outer wall of the pipe. Next the weld-in saddle tool is inserted into the heating sleeve until the saddle surface is up against the convex side of the welding tool. The heating time of the elements is generally 30 seconds.

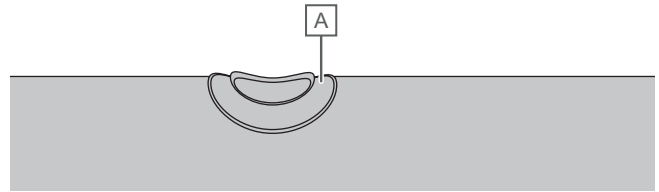

Pos.	Description
A	Melt bead

After the welding tool has been removed, the weld-in saddle tool is immediately inserted into the heated, drilled hole, as shown in below image.

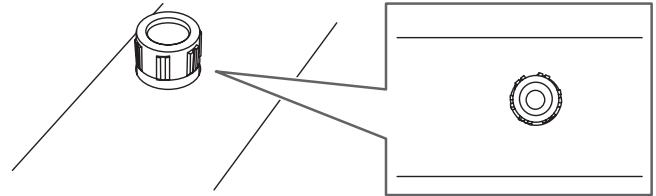

Then the weld-in saddle should be pressed on the pipe for about 15 seconds. After being allowed to cool for 10 minutes the connection can be exposed to its full loading. The appropriate branch pipe is fitted into the sleeve on the Aquasystem weld-in saddle using conventional fusion technology.

Weld-in saddles spacing

Spacing weld-in saddles

When positioning the weld-in saddles on the Aquasystem pipe, the following distances are important:

- Distance between two weld-in saddles
- Distance of the weld-in saddle across the circumference
- Distance between weld-in saddle and fitting

It is also imperative to check that the saddle dimension on the pipe side corresponds to the pipe dimension.

Distance between two weld-in saddles

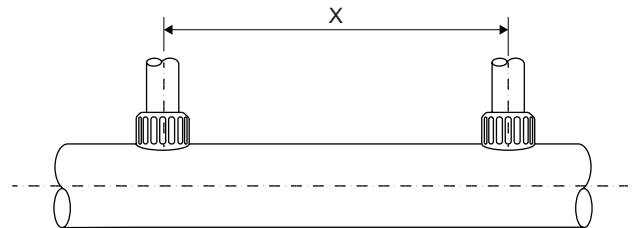

The minimum distance X between two weld-in saddles must be at least 30 mm. This distance applies to pipe dimensions 50 to 225 mm with all outlets. Burst and pulsation tests were conducted on welded in saddles to determine this distance.

Distance of weld-in saddle across circumference

Pipe dimensions d50 to d90

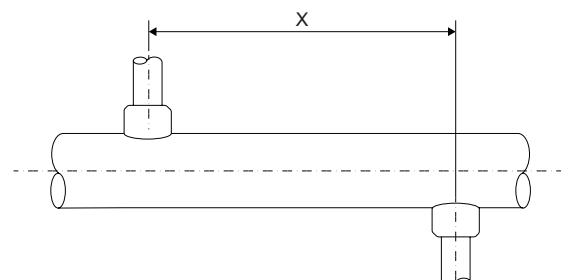

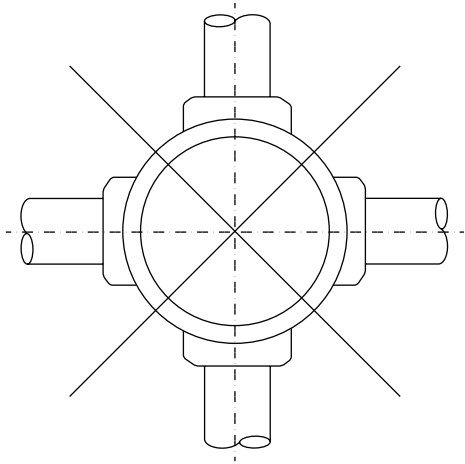

If a weld-in saddle has been welded into the pipe, another or more weld-in saddles may not be welded in across the circumference at this point. Alternatively, another saddle may be welded in with a minimum distance X of 30 mm across the circumference. This applies to pipe dimensions 50 to 90 mm with outlets d20, d25 and d32 mm.

Pipe dimension d110 to d225

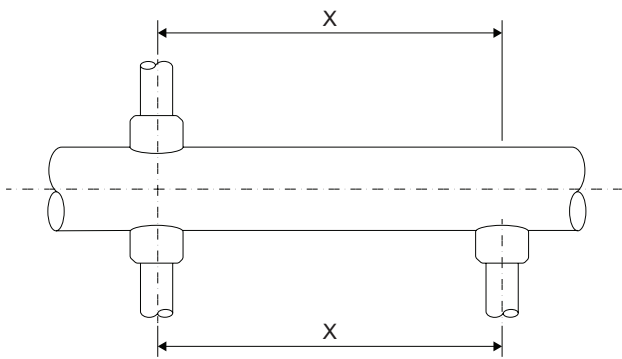

If a weld-in saddle has been welded into a d110 to d225 pipe, it is allowed to weld in another weld-in saddle across the circumference. The minimum distance of $X = 30$ mm from saddle to saddle must be observed in this case as well. It is not allowed to weld in more than 2 saddles across the circumference.

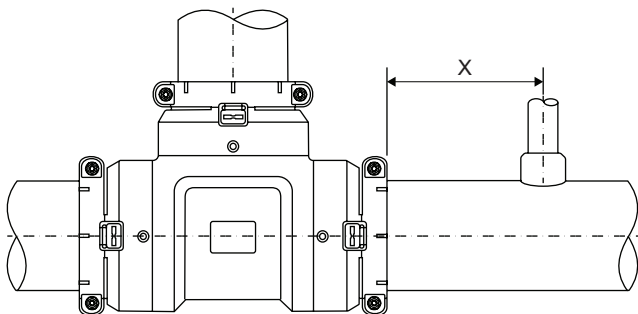

Distance between weld-in saddle and fitting. The minimum distance X between weld-in saddle and fitting must be at least 30 mm. This applies to dimensions 50 to 225 mm irrespective of the outlet dimension.

Electrofusion welding

The electrofusion process

In electrofusion the pipe and the fitting overlap and are fused without auxiliary materials. The heat required to fuse the pipe and fitting is supplied with the help of the resistance wires embedded in the socket. The electrical energy supply is controlled by the electrofusion device.

Fusion preparation



Note

Always take occupational safety measures.

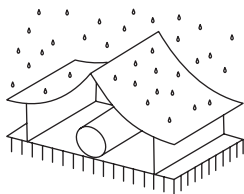

All parts of the system to be fused as well the temperature sensors shall have the same temperature within the acceptable range of temperature (e.g. +5 °C to 40 °C according to DVS 2207).

Cut the pipe

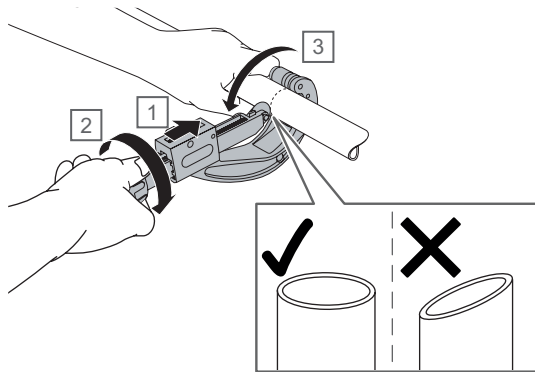

Cut the pipe squarely and deburr the inside of the pipe. Use a plastic pipe cutter

Mark the welding depth



Note

Do not use a wax pencil.

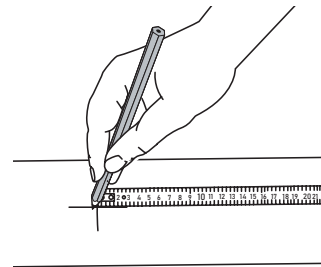
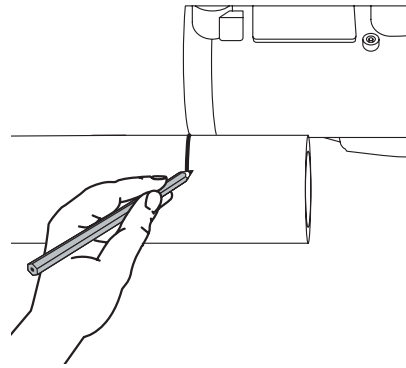
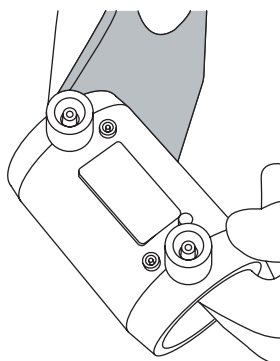

Mark the pipe at half the depth of the fitting as welding depth. The two pipe sections will meet in the middle. Make sure that the marking line remains visible when joining the pipes. Do not use a grease pencil.

Peel the pipe surface



Warning!

If you're working with the UV layered pipes, make sure the peel off UV layers first, using a special peeling tool along the whole pipe section to be inserted into the socket.

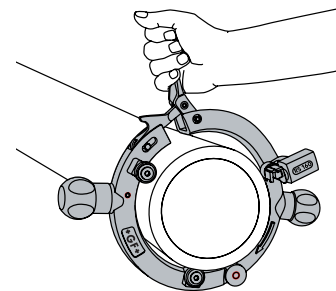

Peel the surface of both pipes up to the marks thoroughly with a peeling tool. Never touch peeled surfaces and protect them against dirt and grease. Start the fusion process within 30 mins after peeling.

Clean the fitting & pipe

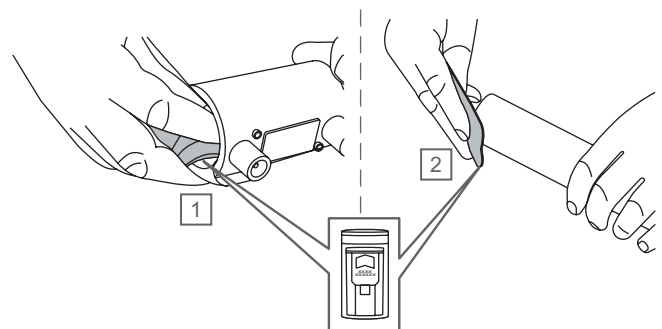

Clean the jointing surfaces of the parts to be joined-fitting and pipe end - immediately before starting. Use an absorbent, lint-free paper and the cleaning fluid Tangit KS cleaner, wipe off all the cleaning fluid with the cleaning paper. Clean the electrofusion socket's inner surface with a lint-free cloth or paper.

Remove moisture that may occur immediately before the welding process again. Keep connecting surfaces clean during all processing steps.

Assembling the electrofusion sockets and pipe

Push the pipes into the fitting up to the marking. Align both ends of the pipe and secure the fitting and the pipe. Make sure the pipe faces butt against each other in the middle of the socket.

Start fusion

Connect the fusion device to the mains.

Plug the fusion cable into resistor pins on the fitting.

Start fusion

Follow the electrofusion machine instructions

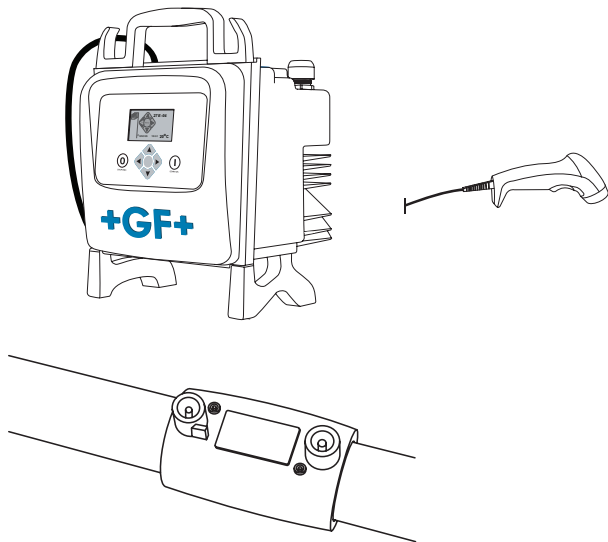

The barcode on the fitting can be read to transmit fusion data to machine. Complete the fusion procedure in accordance with the machine instructions. Ensure the newly made joint remains stress free until the cooling time has elapsed, for more information refer to the below table. 2 hours hardening time must be allowed from when the fitting is cool before conducting pressure tests. During the fusion process the parts to be joined - fitting and pipe - may only be subjected to the forces which normally occur in installation (pipe fastening) according to the guidelines.

Fusion parameters

Cooling times

The joined parts - fitting and pipe - may only be exposed to further installation forces when the cooling time has elapsed.

Pipe dimension [mm]	Cooling time [min]
20	10
25	10
32	10
40	15
50	15
63	15
75	20
90	20
110	20
125	25
160	30

Fusion check

Check the fusion with the optical fusion indicator. A fused socket can be identified by means of the emerging material pin.

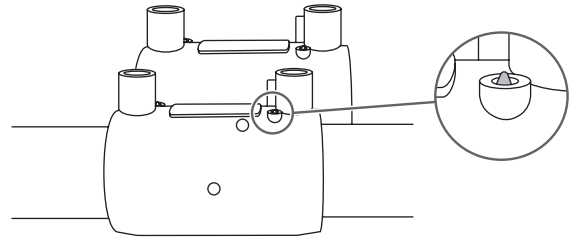

The proper course of an electrofusion welding process is indicated by indicators attached to the moulded part. Only if the indicators (discharging melt, colour change of a display) are fully recognizable, this can be referred to as the completed fusion process.

Pressure test

Before starting the pressure test, all the fusion welds must be fully cooled.

Butt fusion welding

Aquasystem butt fusion of d160 mm and d200 mm.

Principle of the welding process

When using heating element butt fusion, the welding quality required in the design of pressure pipelines depends very much on the compliance with all fusion parameters, for example:

- Parallelism of the pipe and moulding ends
- Offset of the two ends that must be welded
- Differences in wall thicknesses
- Heat up and jointing pressure
- Warm-up and jointing duration
- Heating element temperature

The welding surface corresponds to the annular surface of the pipe, that is to say, the strength of the pipe corresponds to the strength of the weld. As a result, only slight deviations of the fusion parameters, the weld seam loses its strength compared to the pipe.

In this context, this is referred to as the welding factor, which must be $> 0,7$ if welded properly.

Application areas

Butt fusion welding during the construction of pressure pipelines (water and gas supply), must be carried out with a fusion machine in order to be able to meet the required fusion parameters.

Phases in the fusion process

The phases in the welding process are – depending on pressure and temperature – schematically represented as follows:

Phases of the welding process

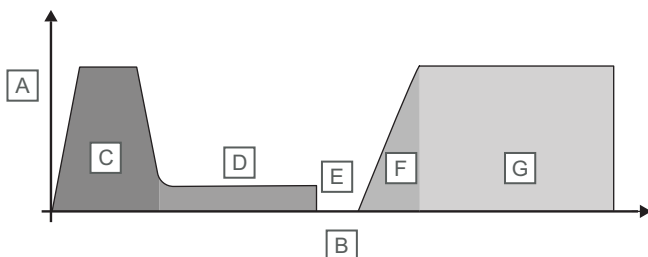

Pos.	Description
A	Pressure
B	Time
C	Adapting
D	Warming up
E	Adjusting
F	Jointing
G	Holding

Process and control

1. Planning the end of the pipe.

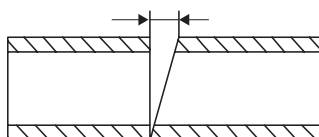

- Gap: maximum 0,5 mm

2. Check the offset on the pipe:

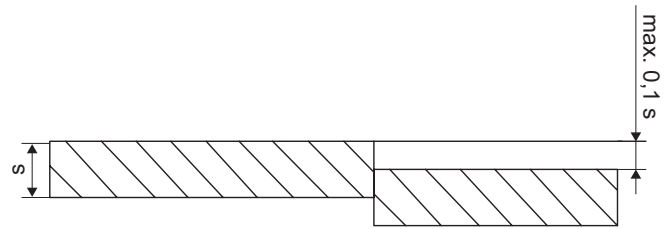

- Offset: maximum 0,1 s

3. Preparing details (A)



- Clean pipe (D) and end of pipe (F).

4. Preparing heating element (E).

5. Determining the settings for adjustment, warming up, jointing and cooling.

6. Aligning and warming up (B).

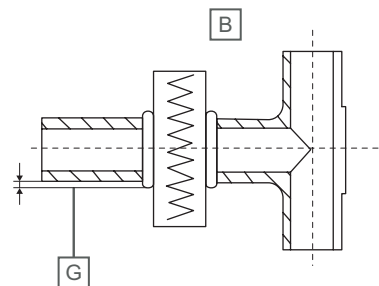

7. Adjusting.

8. Jointing and holding.

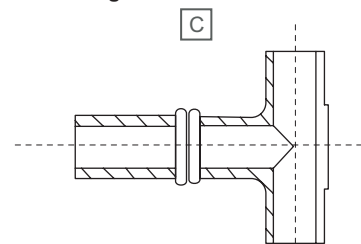

When doing so, the aligning time for the formation of the fusion bead (G) must be observed.

9. Cooling (C).

10. Inspecting the weld seam.

Weld seam inspection



Warning!

Butt welding can be performed only with welding equipment specifically designed for such purpose and only by appropriately qualified staff.

Butt welding is not suitable for coupling pipes and fittings of different size (**the diameter and wall thickness must be same**) or different MFI value.

Welding equipment manuals including welding charts are provided by the manufacturer/supplier of the welding equipment.

The butt welding procedures described here in are based on DVS2207.



Note

Operator should use protective equipment. Always take occupational safety measures.

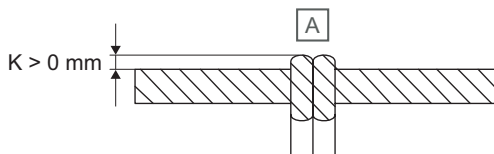

Pos.	Description
A	Fusion beads

Along the entire circumference of the weld, two uniform fusion beads (**A**), as shown in above image. It must be present inside and outside at the weld location.

- Offset: maximum 0,1 x s

Make sure that to reach an optimum welding connection, the heating plate surfaces have to be cleaned before each welding process and be free of visible and invisible residues.

1. Protect the welding equipment and the welding area from the weather.
2. Check the technical condition of the welding machine, whether it works properly and heat it up to.
3. Cut the pipes into required length. After cutting, make sure to remove all burrs and other impurities during cutting.
4. Align and fix the plastic pipes using the clamping elements.
5. Use the milling machine to plane the end of the pipe in a plane parallel manner.
6. Remove the impurities and clean the pipe ends with a Tangit cleaner.
7. Check if the pipes match. (Tolerance: maximum 0,1 x wall thickness).
8. Check the width of the gap between the two pipes to be welded (tolerance: maximum 0,5 mm).
9. Check the temperature of the heating element (210 °C +/- 10 °C)

Wall thickness [mm]	Equalisation pressure p=0,1 N/mm ²	Heating pressure p=0,1 N/mm ²	Maximum changeover period [sec]	Jointing build-up period [sec]	Jointing pressure p=0,1 N/mm ²
	Height of bead [mm]	Heating period [sec]			Cooling time [min]
up to 4,5	0,5	up to 135	5,0	6,0	6,0
4,5 - 7,0	0,5	135 - 175	5,0 - 6,0	6,0 - 7,0	6,0 - 12,0
7,0 - 12,0	1,0	175 - 245	6,0 - 7,0	7,0 - 11,0	12,0 - 20,0
12,0 - 19,0	1,0	245 - 330	7,0 - 9,0	11,0 - 17,0	20,0 - 30,0
19,0 - 26,0	1,5	330 - 400	9,0 - 11,0	17,0 - 22,0	30,0 - 40,0
26,0 - 37,0	2,0	400 - 485	11,0 - 14,0	22,0 - 32,0	40,0 - 55,0
37,0 - 50,0	2,5	485 - 560	14 - 17	32,0 - 43,0	55 - 70

10. Clean the heating element.
11. After positioning the heating element, the pipes are pushed onto the heating plate with a defined adjusting pressure.
12. After reaching the predefined bead height for more information refer to the below table, the pressure is reduced. This process marks the beginning of the heating time. This time is used to heat the pipe ends to the correct welding temperature
13. After the heating time has elapsed, the machine carriage is divided, the heating element is quickly removed and the pipes are joined (both parts of the carriage are put together).
14. The pipes are welded with the required welding pressure and cooled under pressure.
15. The welded joint can be released (unclamped) - the welding process is finished.

Please follow the instructions in the operating manual of the welding machine and observe the DVS 2207- 11 directive.

Follow the butt fusion machine instructions



Note

The part of the Aquasystem UV pipe pipe to be welded must be peeled with special peeling tool before welding.

Carrying out the pressure test

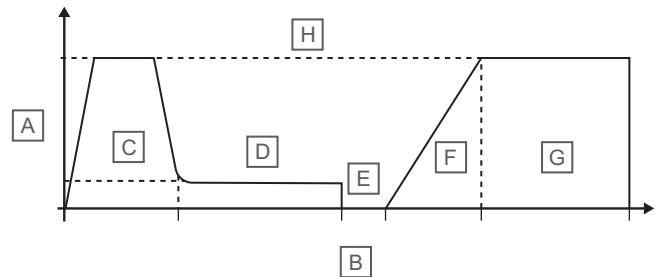

Pos.	Description
A	Pressure
B	Time
C	Equalisation period
D	Heating period
E	Change-over period
F	Jointing build-up period
G	Cooling period
H	Equalisation period = jointing pressure

All fusion joints must be allowed to naturally cooled completely before pressure testing, i.e. as a rule wait about 1 hour after the last joint has been completed.

Weld defects

An optimal fusion joint is, with a few exceptions, always dependent on the capabilities of the fabricator. A well-trained and meticulous user automatically achieves optimal weld joints. The most common imperfections in welded joints are binding defects due to insufficient fusion. Possible causes for these errors are:

Failure to maintain the warm-up, jointing and holding times

- Non-compliance with the welding temperature (too high or too low)
- Contaminated jointing surfaces
- Wrong material pairing
- Material residues on the heating element

Characteristics of welding defects

Other typical characteristic of weld joint imperfections of thermoplastics is listed in DVS 2202, Part 1.

Evidence of the quality of welded joints can be found on the construction site by applying a pressure test and visual inspection.

Welding defects and their correction during heating element butt fusion

Pressure test with water according to DIN 1988

For completely installed but not yet concealed pipes DIN 1988 (Technische Regeln für Trinkwasser- Installation/Technical Regulations for Drinking Water Installations) requires a hydraulic pressure test.

During pressure testing, the properties of the PP-R/PP-RCT pipe material cause an expansion of pipe, which affects the test result. The test result can also be affected by the temperature difference between the pipe and the test medium. A temperature change of 10 K causes a pressure change of 0,5 to 1,0 bar due to thermal expansion. The pressure test of parts of plastic pipe systems should be performed at as much as possible constant test ambience temperature.

The finished pipework shall be filled with filtered water and completely vented.

Pressure testing shall be carried out in two stages, the first stage being sufficient for smaller sections of the system.

1- Preliminary test

For the first stage, a test pressure equal to the permissible working pressure plus 5 bar shall be produced twice within 30 minutes at 10 minute intervals. Then it shall be checked whether, over a further period of 30 minutes, the pressure has dropped by more than 0,6 bar (with a rate of 0,1 bar per 5 minute) and leakage has occurred.

2- Principal test

The second stage shall follow the first stage without interval and shall last two hours.

Then, it shall be checked whether the pressure has dropped by more than 0,2 bar and the pipework shows any signs of leakage.

No leakage shall be found at any section of the tested installation.

Pressure test according to British standard

Pressure test

The pressure test is based on the guidelines of Schedule 2, Part 4 of the Water Supply (Water Fittings) Regulations 1999, governmental guidelines and recommendations from the water industry. The complete installation must be subjected to a pressure test after

completion, while the pipes are still visible. The internal test pressure for all pipes, fittings and joints must be 1,5 times that of the maximum operating pressure of the installation. Piping systems laid above ground must be subjected to a pressure test after completion. Underground piping systems should be tested in sections before being filled. If defects become apparent in the test results, they should be rectified and the system then retested. This condition is met in plastic piping systems when one of the following tests supply satisfactory results.

Test A

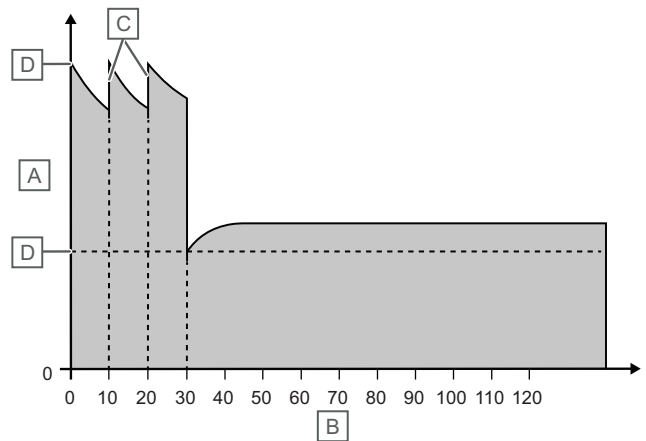

Pos.	Unit	Description
A	Bar	Pressure
B	Minutes	Time
C	-	Pump
D	-	Test pressure 0,33

1. Put the whole system under an internal test pressure which is maintained for 30 minutes by continuous pumping. Afterwards, the test is continued without further pumping.
2. The pressure in the system is slowly reduced to one third of the test pressure.
3. The pressure may not fall over the next 90 minutes, which excludes the possibility of leaks. However, if the pressure does fall, this indicates there is a leak. Or according to paragraph 3.1.12.3.4 (Test procedure A) of BS 6700:1997.

Test B

Warning!	
	Pressure testing with compression joints is done immediately after the last connection has been made. For fusion jointing, you must wait at least one hour.

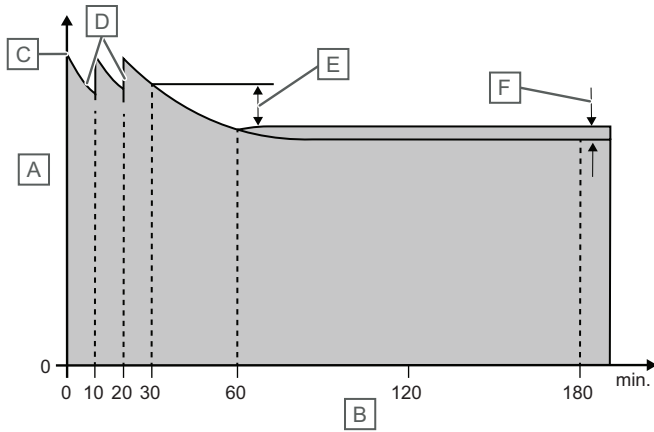



Pos.	Unit	Description
A	bar	Pressure
B	Minutes	Time
C		Test pressure
D		Pump
E		Pressure loss less than 0,6 bar
F		Pressure loss less than 0,2 bar

- Put the whole system under an internal test pressure which is maintained for 30 minutes by continuous pumping. The pressure is noted in the test protocol and the test continued without further pumping.
- Note whether the pressure loss after another 30 minutes is less than 0,6 bar.
- If the pressure loss after another 120 minutes is less than 0,2 bar, there are no leaks in the system. Or according to paragraph 3.1.12.3.4 (Test procedure B) of BS 6700:1997

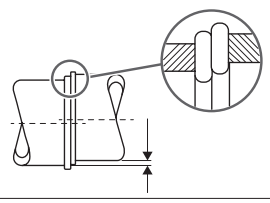
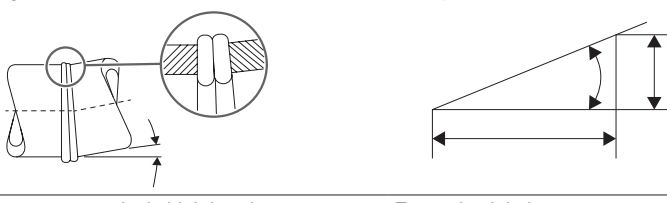
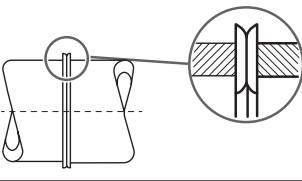
In systems with plastic piping, the pipes expand with increasing pressure marginally beyond the outer diameter due to their elasticity. When the pumping is stopped, the pressure is reduced, i.e. the pressure cannot be maintained for a longer period of time, as is the case for rigid pipes. The test methods A and B have been developed to counteract this problem. (Refer to the image test A and test B). For more information on pressure testing, refer to BS 6700:1997.

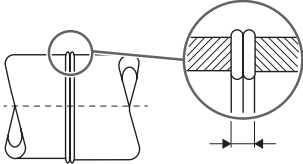
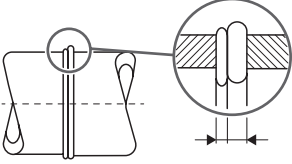
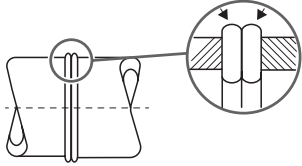
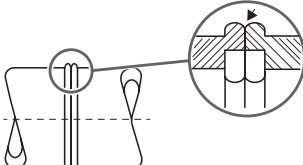
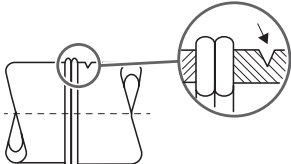
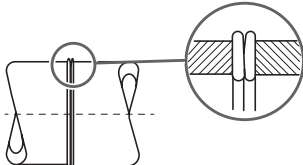
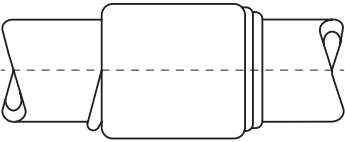
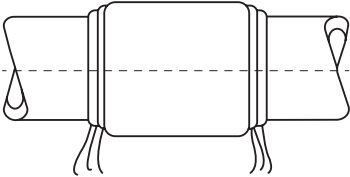
Characteristics	Description and cause	Solution
1. Offset of the jointing surfaces 	Jointing surfaces are offset from each other. <ul style="list-style-type: none"> Set-up error. Clamping devices. Pipe section not perfectly round. 	<ul style="list-style-type: none"> Setting up the machine. Checking the clamping devices. Making pipes round again.
2. Angular deviation 	Set-up error.	Setting up the machine.
3. Narrow, excessively high bead 	Excessive jointing pressure.	<ul style="list-style-type: none"> Check the set-up of the machine. Verifying conversion. Check the jointing pressure of the machine.

Characteristics	Description and cause	Solution
<p>4. Poorly formed welding point</p> 	<p>Fusion bead too wide or too narrow</p> <ul style="list-style-type: none"> • Incorrect warm-up time. • Incorrect temperature on the heating element. • Incorrect jointing pressure. 	<ul style="list-style-type: none"> • Check the warm-up time. • Check the temperature at heating element. • Check the set-up of the machine.
<p>5. Fusion bead uneven</p> 	<ul style="list-style-type: none"> • Defective fusion devices. • Error occurred while preparing the seam. 	<ul style="list-style-type: none"> • Check the set-up of the machine. • Cut pipe at right angle. • Plane jointing surfaces.
<p>6. Thermal damage</p> 	<p>High-gloss surface with bladder or nodule formation</p> <ul style="list-style-type: none"> • Excessive temperature at heating element. • Warm-up time too long. 	<ul style="list-style-type: none"> • Check the temperature at heating element. • Check the warm-up time.
<p>7. Binding error in the plane of the joint</p> 	<p>Insufficient local or planar binding</p> <ul style="list-style-type: none"> • Warm-up time too short. • Insufficient jointing pressure. • Temperature at heating element too low. 	<ul style="list-style-type: none"> • Check the warm-up time. • Check the set-up of the machine. • Check the temperature at heating element.
<p>8. Notches and grooves on the pipe (longitudinal or transverse)</p> 	<ul style="list-style-type: none"> • Clamping device of the machine. • Improper transport. • Error when preparing the weld. 	<ul style="list-style-type: none"> • Check clamping tool. • Ensure proper transport. • Check pipe edge before welding. • Use only suitable tools.
<p>9. Binding error due to bead notches</p> 	<p>Local notch in the fusion bead</p> <ul style="list-style-type: none"> • Insufficient jointing pressure. • Warm-up time too short. • Cooling time too short. • Error when preparing the weld. 	<ul style="list-style-type: none"> • Check the set-up of the machine. • Check the warm-up time. • Holding time and cooling time must be maintained. • Use only suitable tools.
<p>10. Faulty formation of fusion beads</p> 	<ul style="list-style-type: none"> • Impermissible tolerances or obliquely joined. • Warm-up time too long. • Temperature during welding too high or too low. 	<ul style="list-style-type: none"> • Check the dimensions of the pipe, fitting, heating sleeve and socket. • Check the warm-up time. • Check temperature on the heating sleeve.
Different bead formation or non-existent beads)		
<p>11. Thread formation at the fusion bead</p> 	<ul style="list-style-type: none"> • Temperature during welding too low. • Warm-up time too short. • Removing the heating tools too fast. 	<ul style="list-style-type: none"> • Check temperature on the heating sleeve. • Check the warm-up time. • Pull off parts more slowly from the heating tools.

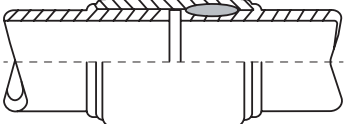
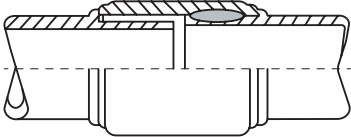
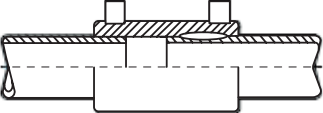
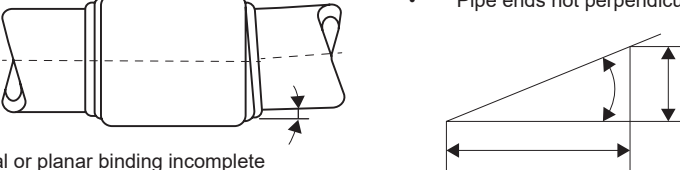
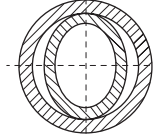
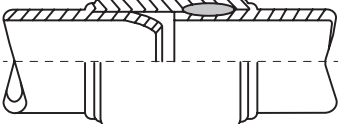
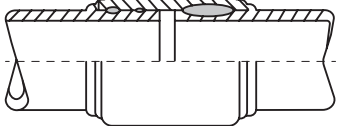
Characteristics	Description and cause	Solution
<p>12. Contaminated fusion bead</p> 	<ul style="list-style-type: none"> • Warm-up time too long. • Contaminated heating sleeve and socket (burnt material). • Contaminated jointing areas. 	<ul style="list-style-type: none"> • Check the warm-up time. • Clean the heating bushing and heating mandrel before each welding process. • Clean pipe and moulded part before welding.
<p>Discolouration of weld bead</p> <p>13. Binding error due to insufficient fusion</p>  <p>Local or planar incomplete welding causing separation in the joint surface</p>	<ul style="list-style-type: none"> • Wrong material pairing. • Contaminated heating sleeve and socket (burnt material). • Contaminated jointing surfaces. • Temperature too low. 	<ul style="list-style-type: none"> • Only join similar materials. • Clean the heating bushing and heating mandrel before each welding process. • Clean pipe and moulded part before welding. • Tighten the heating bushes.
<p>14. Binding error due to inadequate positive locking</p>  <p>Local, planar, axial or circumferential channelling</p>	<ul style="list-style-type: none"> • Notches in the pipe surface. • Inadmissible tolerances. • Incorrect mechanical processing. • Pipe not aligned properly when inserted. 	<ul style="list-style-type: none"> • Check pipe prior to welding. • Check the dimensions of the pipe, moulded part, heating sleeve and heating spigot. • Check processing tools. • Check the clamping device of the machine.
<p>15. Binding error due to incomplete tube insertion</p>  <p>Pipe ends are not adjacent to each other or do not touch the end stop</p>	<ul style="list-style-type: none"> • Tube insertion inadequate. • Pipe ends are oblique. 	<ul style="list-style-type: none"> • Mark insertion depth on the pipe and maintain this depth. • Use a pipe cutter to cut pipe ends at right angles.
<p>16. Angular deviation (permitted up to 1°)</p>  <p>Local or planar binding incomplete</p>	<ul style="list-style-type: none"> • Set-up error of the fusion welding machine. • Pipe ends not perpendicular. 	<ul style="list-style-type: none"> • Check the set-up of the machine. • Use a pipe cutter to cut pipe ends at right angles.
<p>17. Binding error due to deformation</p>  <p>If pipes are not perfectly round, they do not close tightly</p>	<ul style="list-style-type: none"> • Oval pipes due to incorrect storage. • Radius of curvature in coils is too small or clamping device unsuitable. • Squeezing of pipe ends when cutting. 	<ul style="list-style-type: none"> • Before welding, check the pipe ends for out-of-roundness and calibrate or make them round again. • Avoid compression loads. Store pipes properly. • Use system-compatible tools (machine/ devices). • Check cutting tools.
<p>18. Constricted pipe cross-section</p> 	<ul style="list-style-type: none"> • Excessive temperature during welding. • Warm-up time too long. • Jointing pressure too high. • Tube inserted too far during warm-up or jointing. 	<ul style="list-style-type: none"> • Check the temperature of the heating sleeve. • Check the warm-up time. • Check the dimensions of the pipe, moulded part, heating sleeve and heating spigot. • Mark insertion depth on the pipe and maintain this depth.
<p>19. Pores due to the effects of foreign objects</p>  <p>Local or planar binding incomplete</p>	<ul style="list-style-type: none"> • Steam formation during welding (wet pipes). • Contaminated heating tools. • External influences. 	<ul style="list-style-type: none"> • Clean pipes before welding. • Clean heating spigot and heating sleeve before welding. • Protect fusion zones in order to prevent external influences during the fusion process.

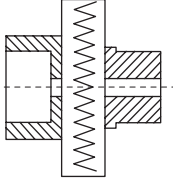
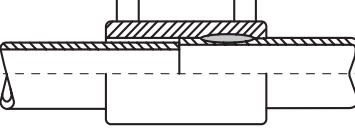
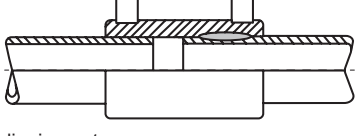
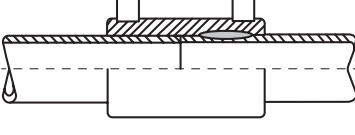
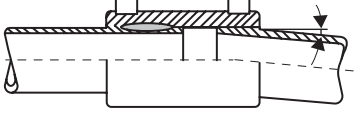
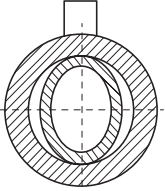
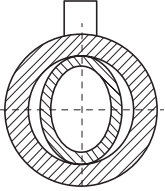
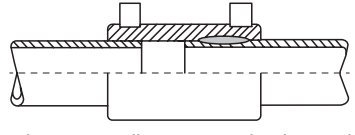
Characteristics	Description and cause	Solution
20. Temperature too high or too low 	<ul style="list-style-type: none"> • Temperature too high or too low. • Heating tools are not completely flush with the surface. • Heating tools are loose. • Voltage fluctuations in the mains. • Contaminated heating tools. 	<ul style="list-style-type: none"> • Correct the temperature. • Check the surfaces of the heating tools and the heating blade. • Tighten the heating tools. • Connect fusion device to separate supply line. • Clean heating spigot and heating sleeve before welding.
21. Binding error due to inadequate positive locking 	<ul style="list-style-type: none"> • Notches in the pipe's surface or in pipe severely out-of-round. • Inadmissible tolerances. • Incorrect mechanical processing. 	<ul style="list-style-type: none"> • Check pipe prior to welding. • Check dimensions on pipe. • Check processing tools.
Local, planar, axial or circumferential channelling		
22. Binding error due to insufficient Positive locking 	<ul style="list-style-type: none"> • Pipes are not fixed inside the socket or welding pressure is not available. 	<ul style="list-style-type: none"> • Ensure the pipes are fixed in place and verify again.
Pipe slipping out		
23. Binding error due to insufficient fusion 	<ul style="list-style-type: none"> • Wrong material pairing. • Contaminated weld areas. • Fusion device defective or not compatible. 	<ul style="list-style-type: none"> • Only join similar materials. • Clean pipe and moulded part before welding. • Check the equipment. • Use system-compatible equipment.
24. Angular deviation (permitted up to 1°) 	<ul style="list-style-type: none"> • Set-up error. • Stress during the fusion process. 	<ul style="list-style-type: none"> • Check clamping tool. • Use a pipe cutter to cut pipe ends at right angles. • Avoid any stresses during the welding process.
25. Binding error due to deformation 	<ul style="list-style-type: none"> • Oval pipes due to incorrect storage. • Radius of curvature in coils is too small or clamping device unsuitable. • Squeezing of pipe ends when cutting. 	<ul style="list-style-type: none"> • Before welding, check the pipe ends for out-of-roundness and calibrate or make them round again. • Avoid compression loads. • Store pipes properly. • Use system-compatible tools (machine/ devices). • Check cutting tools.
If pipes are not perfectly round, they do not close tightly		
26. Binding error due to incomplete tube insertion 	<ul style="list-style-type: none"> • Tube insertion inadequate. • Pipe ends are oblique. 	<ul style="list-style-type: none"> • Mark insertion depth on the pipe and maintain this depth. • Use a pipe cutter to cut pipe ends at right angles.
Pipe ends are not adjacent to each other or do not touch the end stop		
27. Binding error due to inclusion of foreign matter 	<ul style="list-style-type: none"> • Contaminated surface. • Formation of water vapour or gas during the welding process. 	<ul style="list-style-type: none"> • Clean pipes and moulded part before welding. • Only weld dry pipes and moulded parts. • In case of repair: drain all pipes before welding and protect fusion zone from moisture/dirt.
Accumulation of pores, separation in the joint surface		

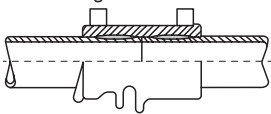
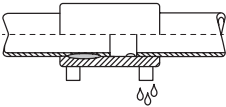
Characteristics	Description and cause	Solution
28. Fusion indication not visible	<ul style="list-style-type: none"> Tolerance error of pipe or moulded part. Joining pressure is not available. Pipes are out-of-round. Insertion depth insufficient. Fusion device defective. 	<ul style="list-style-type: none"> Check dimensions of the pipe and moulded part. Check fusion device.
29. Thermal damage	 <ul style="list-style-type: none"> Welding time excessive. Wrong choice of dimension on the device. Immediately repeat the fusion process. 	<ul style="list-style-type: none"> Check the equipment. Check the set-up. Repeat welding only according to manufacturer recommendations.
30. Fault display or messages on the fusion device	<ul style="list-style-type: none"> Fusion device defective. 	<ul style="list-style-type: none"> Observe the information on the dev or documents provided by the manufacturer. Ask GF Piping Systems or service centre to repair the equipment.
31. Plug-in connector is leaking	 <ul style="list-style-type: none"> Insertion depth of the pipe in the sleeve is not maintained. Resistance wire melts to the core and comes in contact with the medium. This creates a capillary action. 	<ul style="list-style-type: none"> Mark insertion depth on the pipe and maintain this depth. Use a pipe cutter to cut pipe ends at right angles.

Medium is discharging at the plug

Separable connections

Flange connection

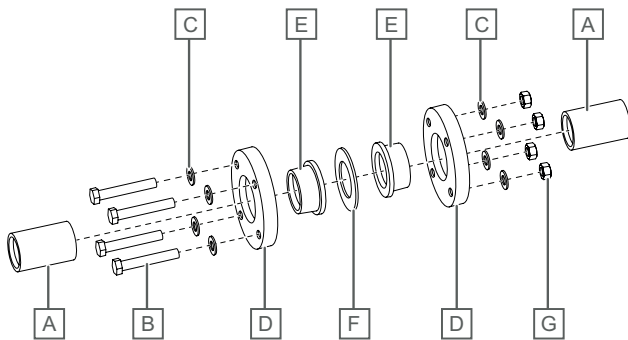

Pos.	Description
A	Pipe
B	Screw
C	Washer
D	Flange
E	Flange adapter
F	Flange seal
G	Nut

It is imperative to use flanges with sufficient thermal and mechanical stability for all connections. The seal dimensions must match the outside and inside diameter of the flange adapter. If the difference exceeds 10 mm between the inside diameters of the gasket and the collar, this may cause interference with the flange connection. Demountable joints or flange connections with a gasket (O-ring) are used to in plastic pipes as well as plastic pipes with valves (valves, pumps) up to dimensions.

Plastic pipe to plastic pipe connection

Detachable fittings or flange connections with a gasket are used to connect plastic pipes and plastic pipes with fittings (valves, pumps) of various dimensions:

When manufacturing flange connections with O-rings, the screw tightening forces that are required are minimum. In order to avoid excessive torque on the screws, it is recommended to use a torque wrench and to follow the manufacturer's instructions for the system.

Plastic pipe to plastic pipe connection

The outside diameter of the gasket is centred around the screws. This ensures that the gasket is always installed around the centre. Screws, nuts, washers (commercially available). Washers must always be used.

Gasket with steel insert

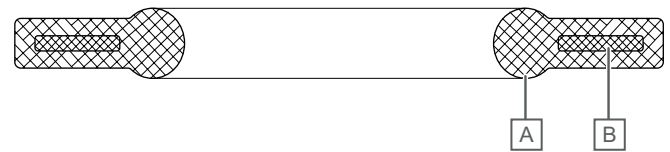

Pos.	Description
A	Gasket
B	Steel insert

Plastic pipe to metal pipe connection

When transitioning from plastic to metal sealed flange connections are used with gasket. Use a torque wrench to bolt flanges to flange adaptors.

Assembly



Note
Leaks due to the bending stress

Do not use bolted connections or flange connections in the area of flexible sections and expansion bends.

Flange adapter respectively the sealing surfaces must always be aligned parallel to each other. A subsequent tightening of the flange connection after the welding process must be avoided. It is important to ensure that the flange faces are clean and undamaged.

The screw length should be selected so that the screw thread is as flush as possible, maximum two threads from the nut. To distribute the force of the screw head and the nut over a larger area, washers are used. Screws, nuts and washers must be clean and undamaged.

In order to achieve proper force distribution (surface pressure) acting on the seal, note the following:

- Screw joints must be tightened diagonally and evenly

- Torque information on the individual flanges must be observed (see table)

For flange connections, exposed to a mutual load, take care that they are checked as part of the maintenance and retightened, if necessary.

It does not take much force to join a flange with an O-ring. That is why we recommend using a torque wrench so as not to overtighten the screws. The following table contains the reference values for fastening the screws in flange connections with O-rings or flange seals:

Flange joints

Creating flange joints

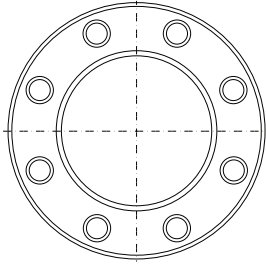

When making a flange connection, the following points have to be taken into consideration:

There is a general difference between the connection of plastic pipes and so-called adapter joints, which represent the transition from a plastic pipe to a metal pipe or a metal valve. Seals and flanges should be selected accordingly.

Flanges with sufficient thermal and mechanical stability should be used. GF flange types fulfil these requirements.

Horizontal pipelines should have the shown orientation of the bolts in order to avoid in case of leakage medium drop on the bolts:

Orientation of bolts outside main axis, (refer to the accompanying diagram of the flange).

When inserting a seal between the flange connections, the dimensions of the seal should be checked to make sure they correspond to the outer and inner diameter of the flange adapters. If the deviation between the inner diameter of the seal and the adapter is more than 10 mm, problems may arise with the flange connection.

Before pre-tightening the bolts, the jointing faces must be flush and must sit closely on the seal. Pulling the pipes together within the flange connection is to be strictly avoided because of the tensile stress which results thereof.

The length of the bolts should be selected so that the thread at the nut does not protrude more than 2 to 3 turns. A washer should be placed under the bolt head and also under the nut.

To make sure that the connecting bolts can be easily removed after a lengthy period of use, the thread should be coated with e.g. molybdenum sulphide.

Torque the bolts diagonal and even, that means: first assemble the bolts and hand tight nut, so that the gasket is perfect in place and the flange adapters have an offset as low as possible. Then torque all bolts diagonal up to 50 % of the recommended torque, at least to 100 % of the torque.

It is recommended to check and if necessary, torque 24 hours after assembling.

After pressure test check and torque if necessary.

For more information to flange connections refer to the DVS 2210-1 Beiblatt 3.

Bolt tightening torque

The torque of the bolts in flange connections is of particular importance. We observe several different methods in practice

As tight as possible

In time this will definitely overstrain a flange connection in plastic piping systems.

By feel

This requires a good deal of experience and material know-how.

Use of a torque wrench

Note	
!	Please observe the special bolt tightening torques given for DN250 and DN300 recommended for butterfly valves, refer to chapter "Fundamentals for butterfly valves, hand operated".

This is the best method. We have listed the recommended values below; however, deviations can occur in practice. These can be caused by the use of, for example, self-locking nuts or pipe axes which are not flush. The Shore hardness of the seal can also influence the necessary torque force (refer to the following information concerning sealing materials).

Bolt tightening torque guidelines for metric (ISO) flange connections with PP-V, PP-steel and PVC flanges.

DN [mm]	d [mm]	Bolt tightening torque guidelines [N/m]		
		Flat gasket up to maximum pressure of 10 bar / 40 °C	Profile gasket up to maximum pressure of 16 bar	O-ring up to maximum pressure of 16 bar
15	20	10	10	10
20	25	10	10	10
25	32	15	10	10
32	40	20	15	15
40	50	25	15	15
50	63	35	20	20
65	75	50	25	25
80	90	30	15	15
100	110	35	20	20
125	125, 140	45	25	25
150	160, 180	60	35	30
200	200, 225	70 ¹⁾	45	35
250	250, 280	65 ¹⁾	35	30
300	315	90 ¹⁾	50	40
350	355	90 ¹⁾	50	-
400	400	100 ¹⁾	60	-
500	450, 500	190 ¹⁾	70	-
600	560, 630	220 ¹⁾	90	-

1) Up to a maximum working pressure of 6 bar.

DN Nominal diameter

d Pipe diameter

The indicated torques are recommended by GF; with these torques a sufficient tightness of the flange connection is ensured. They deviate from the data in the DVS 2210-1 Supplement 3, which are to be understood as upper limit values. Of course our components of the flange connection (adapters, flanges) are designed to withstand these upper limit values.

Dimensions of metric (ISO) flange connections

DN [mm]	d [mm]	Minimum bolt length (calculated)	Maximum bolt length (calculated)	Number of screws x thread diameter
15	20	52	69	4 x M12
20	25	56	73	4 x M12
25	32	60	75	4 x M12
32	40	70	91	4 x M16
40	50	72	95	4 x M16
50	63	78	102	4 x M16
65	75	82	110	4 x M16
80	90	86	114	8 x M16
100	110	89	119	8 x M16
125	125, 140	101	137	8 x M16
150	160, 180	108	145	8 x M20
200	200, 225	¹³⁰	167	8 x M20
250	250, 280	134	177	12 x M20
300	315	150	185	12 x M20
350	355	168	192	16 x M20
400	400	179	207	16 x M24
500	450, 500	249	253	20 x M24
600	560, 630	291	295	20 x M27

DN Nominal diameter

d Pipe diameter

The minimum and maximum bolt lengths are given only for orientation. They are depending from the type of flanges and flange adaptors. Exact values can be calculated from the information refer to the chapter "Length of bolts".

Bolt tightening torque guidelines for metric ANSI flange connections with PP-V, PP-steel and pvc flanges.

DN [Inch]	DN [mm]	Bolt tightening torque guidelines [N/m]	
		Flat gasket up to maximum pressure of 10 bar / 40 °C	Profile gasket up to maximum pressure of 16 bar
½	15	15	10
¾	20	15	10
1	25	15	10
1 ¼	32	15	10
1 ½	40	15	10
2	50	30	20
2 ½	65	30	20
3	80	40	30
4	100	30	20
6	150	50	33
8	200	50	33
10	250	60 ¹⁾	40
12	300	75 ¹⁾	53

1) Up to a maximum working pressure of 6 bar.

DN Nominal diameter

Selection of the seals for flange connections

With consideration to the operating conditions and the sealing forces, the selection of suitable flange seals in thermoplastic piping systems depends on the following factors:

- Form
- Dimension
- Material

Form of the seal

The seal can be a flat gasket, flat gasket with profile, or O-ring. In applications with low working pressures the customary flat gasket, which is made of 2 to 5 mm thick sheet material (depending on the nominal diameter) is used. For flange connections with flat gaskets, flanges which are sturdy enough to withstand the higher torque required for fastening the bolts in such connections are necessary. The flanges from GF meet these requirements.

For increased working and testing pressures, the flat gaskets with profiles and O-rings have proved useful. Compared to the flat gasket, the profiled flat gasket is made of two components. One is the crowned flat gasket part which is reinforced with steel, and the other is the profiled part (O-ring, lip seal) on the seal inner side.

Advantages of stabilized profile flat gaskets and O-rings:

- Reliable seal with little screw torque
- Can be used with higher internal pressure and internal vacuum
- Easy to install
- Influenced less by the flange surface
- Safe when connecting pipes of different materials.

Selection of suitable seals, related to the form, can be done with the table below.

Seal form	Recommended limits	Flange version
Flat gasket	P = 10 bar, above DN200 only to 6 bar T = 40°C	With sealing grooves
Flat gasket, profiled	P = 16 bar T = whole application range	With or without sealing grooves
O-ring	P = -1 - 16 bar T = whole application range	With groove

Dimensions of the seal

The dimensions of the seal are determined in the general standards for pipe jointing components. Divergences in the inner or outer diameter of the seal as compared to the flange adapter can in some cases lead to increased mechanical stress of the flange connection, to accelerated wear of the inner side of the seal as well as deposits inside the pipe.

Seal material

The choice of a seal material is based on the flow media. Details on the suitability of the seal material, or specifically the chemical resistance, can be found in our resistance tables.

The use of seal materials with a high degree of hardness, e.g. as in steel pipes, is restricted in thermoplastic piping systems because the flange or the adapter could become deformed under the great sealing forces. Elastomer materials, such as EPDM, CSM or FPM with a Shore-A-hardness up to 70 ° are preferable.

Joining plastic piping components via screw connections

Wherever available, unions are the preferred choice over flange adaptors for the connection of plastic pipes. With no metal parts, there is no corrosion and the weight is also reduced. In addition, the smaller outer diameter means the distance from pipe axis to pipe axis is smaller compared to a flange connection.

Unions are available in several materials:

4.3 Thermal expansions

Linear expansion of pipes depends on the difference between the operating temperature and the installation temperature:

$$\Delta T = T_{\text{Operating Temperature}} - T_{\text{Installation Temperature}}$$

Therefore, thermal expansion values of cold water applications could be neglected. For hot water applications, the expansions should be calculated due to the linear expansion depending upon the temperature of the material, and the clamp distances should be adjusted based on the tables.

It should be taken into account that the critical parameter is thermal expansion coefficient.

- Linear expansion coefficient of Aquasystem PP-R Standard pipes is **0,150 mm/m°K**.
- Linear expansion coefficient of Aquasystem Faser Fiberglass Reinforced and Climafaser Fiberglass Reinforced PP-R pipes is **0,035 mm/m°K**.
- Linear expansion coefficient of Aquasystem Aluminium Foiled (Stable-Aluplus) PP-R pipes is **0,030 mm/m°K**.

Installation calculations

The total linear expansion (ΔL) is calculated using the following formula:

$$\Delta L = L_T \times \alpha \times \Delta T$$

ΔL ; Linear expansion [mm]

L_T ; Pipe installation length [m]

α ; Linear coefficient of thermal expansion

ΔT ; Temperature difference between operating and installation temperature °K , °C , °F

The following tables provide pre-calculated expansion values based on pipe length and temperature differences.

For example, 2 m-long Aquasystem Glass Fiber Reinforced (Faser) PP-R pipe operates at 65°C and installed at 25°C, rectilinear expansion is calculated as follows:

$$\Delta L = L_T \times \alpha \times \Delta T$$

$$\Delta L = 2 \times 0,035 \times 40$$

$$\Delta L = 2,8 \text{ mm}$$

Briefly, if a 2 meter long system is made with Aquasystem Glass Fiber Reinforced PP-R product and is exposed to 40 °C temperature difference, the system demonstrates 2,8 mm thermal expansion.

Thermal expansion of standard PP-R pipes

Thermal expansion of standard PP-R pipes [mm]		a = 0,150 mm/m°K							
		Temperature differences [°C]							
Pipe length [m]	10 °C	20 °C	30 °C	40 °C	50 °C	60 °C	70 °C	80 °C	
1,0	1,5	3,0	4,5	6,0	7,5	9,0	10,5	12,0	
2,0	3,0	6,0	9,0	12,0	15,0	18,0	21,0	24,0	
3,0	4,5	9,0	13,5	18,0	22,5	27,0	31,5	36,0	
4,0	6,0	12,0	18,0	24,0	30,0	36,0	42,0	48,0	
5,0	7,5	15,0	22,5	30,0	37,5	45,0	52,5	60,0	
6,0	9,0	18,0	27,0	36,0	45,0	54,0	63,0	72,0	
7,0	10,5	21,0	31,5	42,0	52,5	63,0	73,5	84,0	
8,0	12,0	24,0	36,0	48,0	60,0	72,0	84,0	96,0	
9,0	13,5	27,0	40,5	54,0	67,5	81,0	94,5	108,0	
10,0	15,0	30,0	45,0	60,0	75,0	90,0	105,0	120,0	

Thermal expansion of glass fiber reinforced (Faser) PP-R pipes

Thermal expansion of glass fiber reinforced (faser) PP-R pipes [mm]		a = 0,035 mm/m°K							
		Temperature differences [°C]							
Pipe length [m]	10 °C	20 °C	30 °C	40 °C	50 °C	60 °C	70 °C	80 °C	
1,0	0,4	0,7	1,1	1,4	1,8	2,1	2,5	2,8	
2,0	0,7	1,4	2,1	2,8	3,5	4,2	4,9	5,6	
3,0	1,1	2,1	3,2	4,2	5,3	6,3	7,4	8,4	
4,0	1,4	2,8	4,2	5,6	7,0	8,4	9,8	11,2	
5,0	1,8	3,5	5,3	7,0	8,8	10,5	12,3	14,0	
6,0	2,1	4,2	6,3	8,4	10,5	12,6	14,7	16,8	
7,0	2,5	4,9	7,4	9,8	12,3	14,7	17,2	19,6	
8,0	2,8	5,6	8,4	11,2	14	16,8	19,6	22,4	
9,0	3,2	6,3	9,5	12,6	15,8	18,9	22,1	25,2	
10,0	3,5	7,0	10,5	14,0	17,5	21,0	24,5	28,0	

Thermal expansion of aluminium foil PP-R pipes

Thermal expansion of aluminium foil PP-R pipes [mm]		a = 0,030 mm/m°K							
		Temperature differences [°C]							
Pipe length [m]	10 °C	20 °C	30 °C	40 °C	50 °C	60 °C	70 °C	80 °C	
1,0	0,3	0,6	0,9	1,2	1,5	1,8	2,1	2,4	
2,0	0,6	1,2	1,8	2,4	3,0	3,6	4,2	4,8	
3,0	0,9	1,8	2,7	3,6	4,5	5,4	6,3	7,2	
4,0	1,2	2,4	3,6	4,8	6,0	7,2	8,4	9,6	
5,0	1,5	3,0	4,5	6,0	7,5	9,0	10,5	12,0	
6,0	1,8	3,6	5,4	7,2	9,0	10,8	12,6	14,4	
7,0	2,1	4,2	6,3	8,4	10,5	12,6	14,7	16,8	
8,0	2,4	4,8	7,2	9,6	12,0	14,4	16,8	19,2	
9,0	2,7	5,4	8,1	10,8	13,5	16,2	18,9	21,6	
10,0	3,0	6,0	9,0	12,0	15,0	18,0	21,0	24,0	

Thermal elongation compensation

All piping systems need an adequate gap for thermal expansion. The necessary gaps should be created on the system through thermal expansion compensation so that no extra tension is created on the system due to temperature differences and the system is not damaged. In the vertical lines (riser), thermal expansion compensation is not required. However, in the horizontal lines, thermal expansion compensations should be included into the system by using the following calculations and designs.

Free expansion

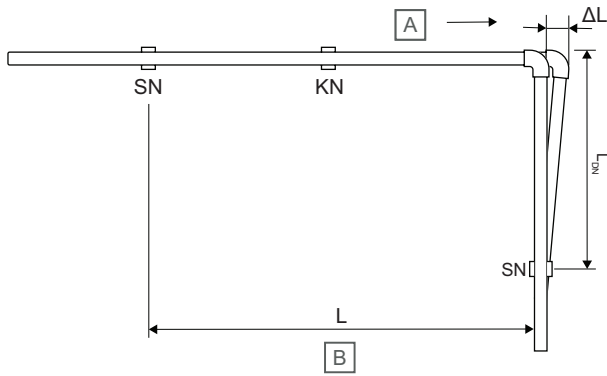

Pos.	Description
A	Thermal expansion direction
B	Free expansion

Terms	Abbreviation
ΔL	Total thermal expansion [mm]
L_{DIN}	Free expansion
KN	KN-style fixed support
SN	SN-style sliding support
L	Length of pipe run [m/mm]

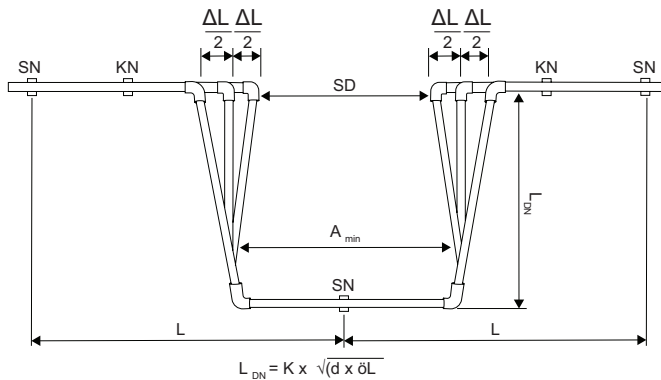

Terms	Abbreviation
ΔL	Total thermal expansion [mm]
L_{DIN}	Free expansion
KN	KN-style fixed support
SN	SN-style sliding support
L	Length of pipe run [m/mm]
A_{min}	Minimum thermal expansion compensation width [mm]

Fixed Points (FP) block the undesired movements of the system. These fixed points are created by using fasteners. Fixed points should be more resistant and stable than sliding points (SP). It is not recommended to use fixed points at bending areas. Thermal expansion compensation can be calculated according to the following formula by taking the free movements into consideration:

$$A_{min} = 2 \times \Delta L + SD$$

A_{min} : minimum thermal expansion compensation width [mm]

ΔL : total elongation of the system from fixed point [mm]

SD : safety gap (150 mm)

The adjustments of thermal expansion compensation are generally calculated as uniaxial (along the pipe). To avoid any additional stress in the system, PP-R pipes should freely expand in the axial direction. Safety gap specified as 150 mm should be increased if there are temperature difference fluctuations in the system.

If the system is biaxial (horizontal and vertical) and longer than 5 m, thermal expansions should be calculated and the following expansion cycles should be used.

Distances between clamps in PP-R installation

Standard PP-R pipes											
Temperature differences	Clamp distances [cm]										
ΔT [°C]	d20	d25	d32	d40	d50	d63	d75	d90	d110	d125	d160
0	85	105	125	140	165	190	205	220	250	270	290
20	60	75	90	100	120	140	150	160	180	200	230
30	60	75	90	100	120	140	150	160	180	200	230
40	60	70	80	90	110	130	140	150	170	180	200
50	60	70	80	90	110	130	140	150	170	180	200
60	55	65	75	85	100	115	125	140	160	170	180
70	50	60	75	80	95	105	115	125	140	155	180

Glass reinforced PP-R											
Temperature differences	Clamp distances [cm]										
ΔT [°C]	d20	d25	d32	d40	d50	d63	d75	d90	d110	d125	d160
0	115	130	150	165	185	215	240	260	280	300	320
20	90	100	115	130	145	165	185	200	215	225	250
30	90	100	115	130	145	165	185	200	210	235	255
40	80	90	105	120	135	155	175	190	200	215	230
50	80	90	105	120	135	155	175	190	180	200	210
60	70	80	100	115	130	145	165	180	175	190	200
70	65	75	90	105	120	135	155	175	175	190	200

Aluminium foil pipes											
Temperature differences	Clamp distances [cm]										
ΔT [°C]	d20	d25	d32	d40	d50	d63	d75	d90	d110	d125	d160
0	120	140	160	180	205	230	245	260	280	300	320
20	90	105	120	135	155	175	185	200	215	225	250
30	90	105	120	135	155	175	185	200	210	235	255
40	85	95	110	125	145	165	175	190	200	215	230
50	85	95	110	125	145	165	175	190	180	200	210
60	80	90	105	120	135	155	165	180	175	190	200
70	70	80	95	110	130	145	165	175	175	190	200

4.4 Installation in shaft

During the installation of the pipes from the main line to the apartments in a building, one of the following techniques is used to allow the pipes to expand linearly.

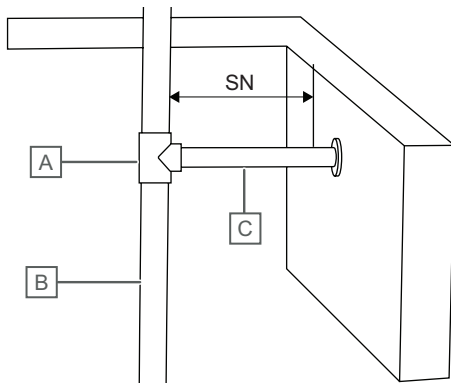

Pos.	Description
A	90 ° tee
B	Main pipe
C	Apartment entry pipe

- When a branch is embedded in concrete, as shown as in above image, the SN distance between the tee and wall opening should be ensured to allow for

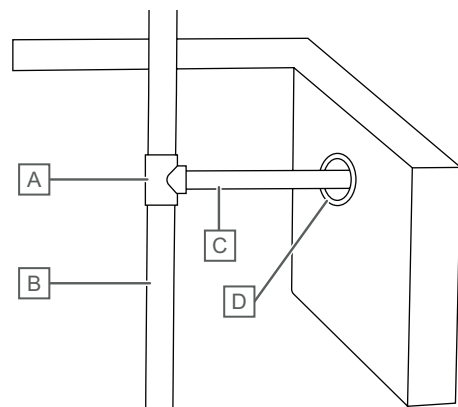

Pos.	Description
A	90 ° tee
B	Main pipe
C	Apartment entry pipe
D	Pipe duct

The hole diameter inside the wall should be bigger than the pipe diameter which passes through the wall as shown in above image
 The diameter of the hole must be specified in such a manner that the branch is able to move during expansion of the main pipe.

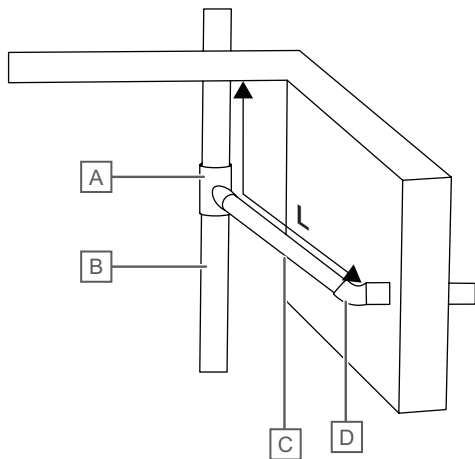

Pos.	Description
A	90° tee
B	Main pipe
C	Apartment entry pipe
D	90° elbow

The L-shaped pipe segment as shown in above image. It is used to compensate for length variations due to thermal expansion.

- The horizontal spacing of fixed clamps depends on the size and type of pipe.

5 Maintenance

5.1 Transport and storage

Aquasystem pipes and fittings can be stored for a long time at variable temperatures thanks to the material properties of polypropylene.

However, Aquasystem pipes and fittings must be stored and handled under the following conditions:

- Always store the pipe on a flat surface. The pipes should be supported along their full length.
- Bending of the pipes must be avoided.
- Always handle the ends of the pipe carefully. Avoid hard knocks or impacts at the end of a pipe. Do not use pipes which are damaged or cracked at the surface. If the pipe is exposed to impact or stress, inspect it for damage. Damaged ends or sections should be marked and removed before installation. Surface scratches deeper than 10 % of the wall thickness are considered damage.
- In cold weather, in particular at temperatures below 0 °C, the material becomes sensitive to impact. Take extra care when handling the pipe. For this reason, knocks and similar impacts are to be avoided under these conditions.
- High-polymer materials are sensitive to UV radiation. For this reason, avoid exposure to UV-radiation.
- Never place the forks of a forklift into the ends of the pipe. This will damage the pipe and can cause it to crack. Handlers may use a padded rug ram inside the pipe. Otherwise, it is recommended to use a crane or lift to handle larger pipes.
- Do not twist either pipe or fitting after joining together.
- Put pipes down carefully.
- Cut pipes only with sharp tools.
- Store protected against sun and rain.
- Cover pipes at risk, to prevent damage.

6 Technical data

6.1 Technical specifications

Item	Features	PP-R/PP-RCT	PP-R/PP-RCT Fiberglass
Technical properties	Melt flow index 190 °C/5 kg	0,5 g/10 min	0,5 g/10 minutes
	Melt flow index 230 °C/2,16 kg	0,3 g/10 min	0,3 g/10 minutes
	Modulus of elasticity	800 N/mm ²	1200 N/mm ²
	Yield stress	25 N/mm ²	30 N/mm ²
	Density	~0,9 g/cm ³	~ 0,95 g/cm ³
	Tensile strength	25 MPa	35 MPa
	Thermal expansion coefficient	1,5 x 10 ⁻⁴ K ⁻¹	0,35 x 10 ⁻⁴ K ⁻¹
	Coefficient of thermal conductivity	0,24 W/mK	0,15 W/mK
	Coefficient of friction in pipes	0,007	0,007
	Water absorption	< 0,02 %	< 0,02 %



**Georg Fischer Hakan Plastik
Boru ve Profil San. Tic. A.Ş.**

Ofishane Plaza Merkez Mh. Cendere Cd.
No:22 K:11 34400 Kağıthane / İstanbul
Türkiye

1239746 v2_06_2026
GF / SKA

Uponor reserves the right to make changes, without prior notification,
to the specification of incorporated components in line with its policy
of continuous improvement and development.



www.uponor.com