

Fact Sheet Stormwise Vault

Effective solution for stormwater purification

Removal of pollutants from stormwater

The GF Stormwise Vault is used for an extensive purification of high amounts of highly contaminated stormwater. Floating debris, plant parts and other large particles accumulate in the pre-treatment section. The second section contains an array of filter cartridges for the removal of smaller sediments and heavy metals.

A Vault is used if a high water flow is expected and a high level of purification is needed.

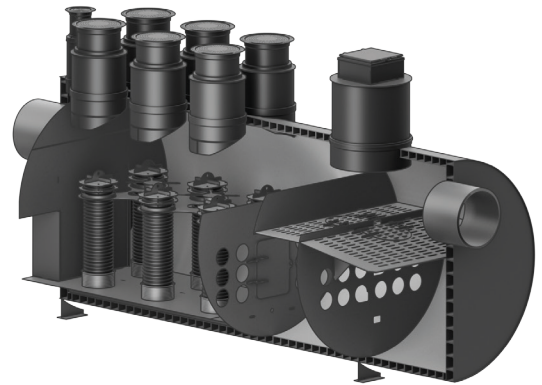

Compliant with local regulations

Accelerates your project timeline and simplifies approvals by authorities.



Complete and prefabricated

Saves up to 50% installation time and reduces risks for installation errors.



Compact and robust

Saves up to 50% space and allows flexible placement, even under traffic load.



Convenient and accessible

For reliable operation and easy maintenance.

Technical data

Application	Purification of stormwater
Material (body)	PE 100
Color	Black (outside), white (inside)
Filter size	1.5 m or 2.0 m
Inner diameter (ID)	2400 - 3500 mm
Length (L)	4000 - 18000 mm
Height (H)	Customizable
In/out diameter (DN)	300 - 1200 mm
Weight	2040 - 13980 kg
Inlet position below ground level (h1)	Customizable
Outlet position below ground level (h2)	Customizable
Body position below ground level (h3)	Customizable
Catchment volume	750 - 30000 m ³
Functional flow rate	7.5 - 300 l/s
Maximum flow rate	75 - 3000 l/s
Retention time over the filter	8 - 38 s

Approvals	IKT seal
Standards	EN 13476 EN 13598 DWA-A 102-2 category III

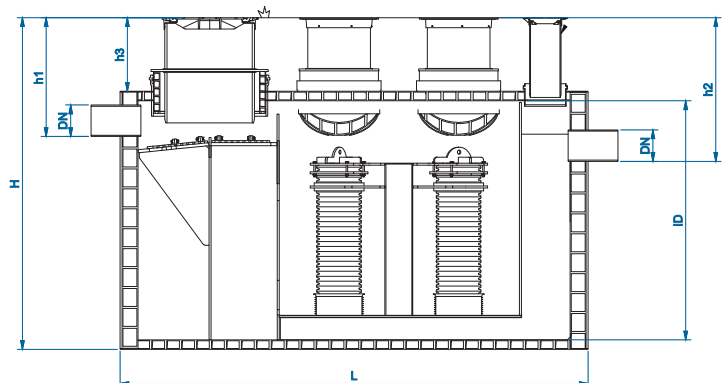

Components

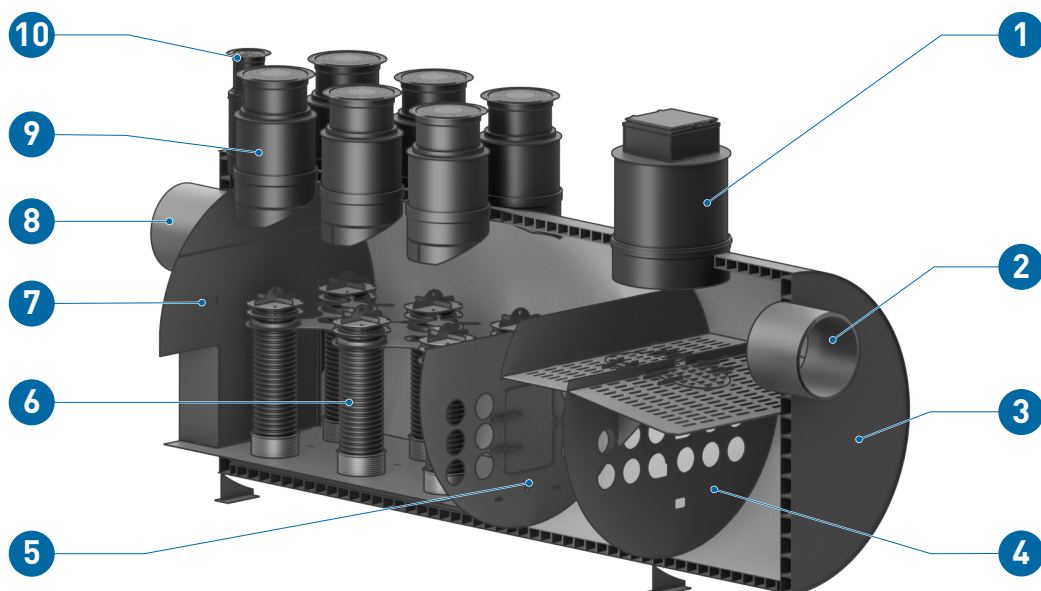

Pos.	Designation	Pos.	Designation
1	Manhole riser	6	Array of filter cartridges
2	Inlet	7	Separating wall
3	Body	8	Outlet
4	Waste grid (optional)	9	Service riser for filter exchange
5	Flow equalization plate with service door	10	Inspection riser

Customizable components

- Chamber size
- Riser height
- Riser top types

Riser top types and sizes (selection)

Type A	Type B	Type C	Type D	Type E
ø860/800 With safety gate	600x600 metal 800x800 metal	ø600 GE 40tn ø630 GE 40tn	ø160 GE 40tn ø315 GE 40tn ø630 GE 40tn ø800 GE 40tn	ø600 no lid ø800 no lid ø1000 no lid
				

Optional components

- Waste grid
- Oil absorber
- Alarm system

Item numbers

Item no.	Description
35001138348	Vault
35001135105	Filter 1.5 m
35001135106	Filter 2.0 m
35001144331	Filter material



Speak to an expert
Discover how Stormwise solutions can transform your stormwater management.
www.gfps.com/stormwise

The information and technical data (altogether "Data") herein are not binding, unless explicitly confirmed in writing. The Data neither constitutes any expressed, implied or warranted characteristics, nor guaranteed properties or a guaranteed durability. All Data is subject to modification. The General Terms and Conditions of Sale of Georg Fischer Piping Systems apply.

