

GF Hycleen Flush & Shut-off

JRG code 9970.xxx

EN Technical information

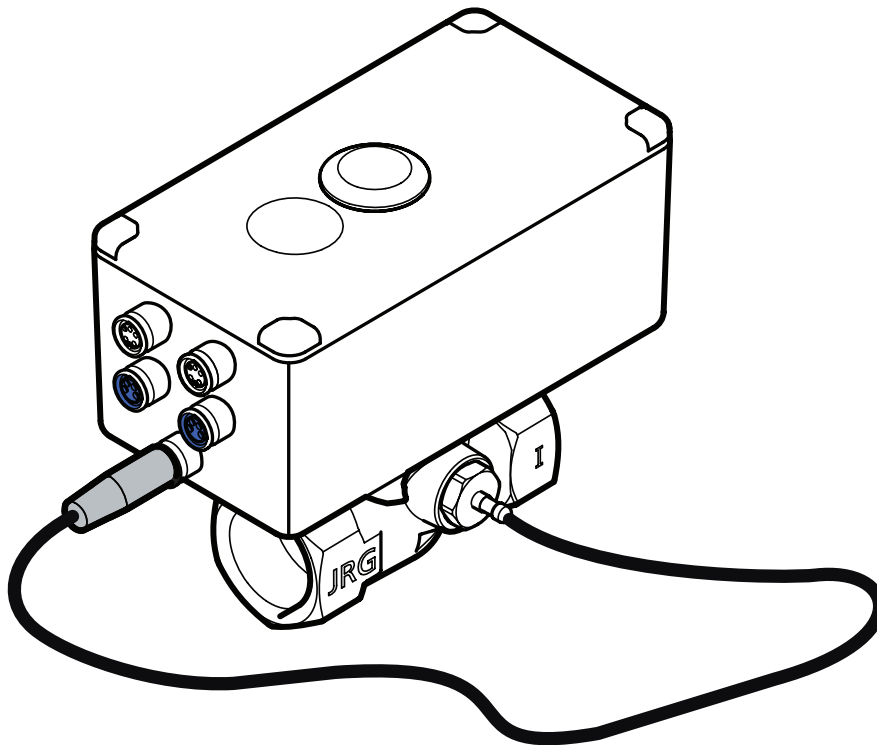

Table of contents

EN

Copyright and disclaimer	3	9 Flushing capacity curves.....	25
1 System description	4	9.1 Flushing capacity of GF Hycleen Flush valve DN 15	25
1.1 Function and benefits	4	9.2 Flushing capacity of GF Hycleen Flush valve DN 20	26
1.2 Structure of the GF Hycleen Flush & Shut-off valve.....	5	10 Regulatory conformance	27
2 Components.....	6		
2.1 GF Hycleen Flush valve	6		
2.2 GF Hycleen power supply unit.....	6		
2.3 GF Hycleen insulation	7		
2.4 GF Hycleen power supply and communication cable.....	7		
2.5 GF Hycleen cable coupling.....	7		
2.6 GF Hycleen BMS connection and bus extension	8		
2.7 GF Hycleen flow sensor	8		
2.8 GF Hycleen AS temperature sensor.....	9		
2.9 GF Hycleen temperature sensor	9		
2.10 GF Hycleen drain monitoring sensor.....	10		
3 Example system	11		
3.1 Install the flow sensor to flush depending on volume	11		
3.2 Install the flow sensor to flush depending on consumption	11		
4 Installation.....	12		
4.1 Install the controller	12		
4.2 Temperature sensor.....	13		
4.3 Cabling in series	13		
4.4 Cable connection between the controllers.....	14		
5 Commissioning.....	16		
5.1 Electrical connection.....	16		
5.2 Interaction button.....	16		
5.3 Commissioning / Bluetooth connection	17		
5.4 LED coding	18		
6 Connection to building control technology (BMS).....	19		
7 Technical data.....	21		
8 Error messages and troubleshooting.....	22		
8.1 Error categories	22		
8.2 Troubleshooting	23		

Copyright and disclaimer

Uponor and JRG are part of Georg Fischer AG (GF) and are used to specify the portfolio. All contents of this chapter that apply to GF also apply to Uponor and JRG.

The designations used in this manual are brand names, registered trademarks, trade names or use names of the respective manufacturers and are subject to corresponding property rights.

"Georg Fischer", "+GF+", "Uponor" and "JRG" are registered trademarks of Georg Fischer AG

GF has created this document for informational purposes only. The images are representations of the products only. The content (text and images) of the document is protected by worldwide copyright laws and contractual provisions. By using this document, you agree to comply with these laws and provisions. The modification or use of content for other purposes constitutes a violation of the copyright, trademark and other proprietary rights of GF.

This disclaimer applies to, but is not limited to, the accuracy, reliability or correctness of the document.

The document assumes that the product-related safety instructions are obeyed in full. The requirements that follow are applicable to the GF product (including all components) as described in this document.

- A competent planner must select and design the system (combination of products). A licenced and/or competent fitter must install and commission the system in accordance with the instructions provided by GF. Obey local construction and installation regulations.
- Make sure that the temperature, pressure and/or voltage are not more than the limits specified in the product and design information.
- The product must stay at its original site and you must repair, replace or change it without prior written consent from GF.
- The product is connected to the drinking water supply or to compatible sanitary, heating and/or cooling systems approved or specified by GF.
- Do not connect or use the product with any third party product, part or component unless approved or specified by GF.
- The product must have no evidence of manipulation, incorrect use, inadequate maintenance, improper storage, neglect or accidental damage prior to installation and commissioning.

Although GF has made every effort to make sure that this document is correct, the company does not guarantee or warrant the precision of the information. GF reserves the right to change the product portfolio and related documentation within its policy of continuous improvement and development without prior notice.

Always make sure that the system or product complies with local standards and regulations. GF cannot guarantee that the product portfolio and related documents comply with all local regulations, standards or working methods.

GF disclaims all express or implied warranties with respect to the content of this document, unless otherwise agreed or necessary by law.

GF is under no circumstances liable for indirect, special, incidental or consequential damage resulting from the use or inability to use the product portfolio and related documents.

This disclaimer and all provisions in this document do not restrict the legal rights of consumers.

1 System description

EN

1.1 Function and benefits



The GF Hycleen Flush & Shut-off is an electronically controlled flush and shut-off valve that prevents stagnation in drinking water systems. The valve uses temperature and flow sensors to continuously monitor water temperature, water consumption and flow. The flushing processes for single drinking water lines decrease biofilm formation and make sure that microbiological contamination stays low.

Flushing processes are time-, temperature- or consumption-controlled. If the water temperature is not in accordance with the temperature setpoint, the valve opens automatically to let stagnant water be replaced with fresh water. The measured temperatures are kept and are available for download for one year.

This gives GF Hycleen Flush & Shut-off the key advantages that follow:

Health: As water stagnation is prevented, the growth of biofilms that contain dangerous microorganisms such as Legionella is stopped.

Documentation of the history: GF Hycleen Flush & Shut-off makes sure that every drinking water system is correct for current operation and, in many respects, operation in the future. Digital documentation of flushing processes and flow rates helps operators to reliably show compliance with drinking water safety regulations and recommendations.

The automatic flushing function: The unfluctuating renewal of the water in all pipe sections increases hygiene and extends the life of the entire installation.

This targeted support for hygienic flushing processes adds safety in buildings where stagnation is to be prevented or microbiological contamination is to be specifically decreased (e.g. hospitals, hotel chains, care facilities).

Easy to install, intuitive to operate: The automatically documented history keeps the effort of the operator, owner or facility manager to a minimum and prevents time-consuming maintenance and alarm procedures.

Versatile to use: It is possible to use the system in all commercial and public buildings, such as multi-family homes, hotels, hospitals, care facilities, schools, sports facilities etc. It is possible to use the system in new buildings and renovations.

In summary, GF Hycleen Flush & Shut-off offers two primary functions: An automatic flushing function and programmable shutdowns.

The flushing function makes sure that the water is replaced in an automated, demand-controlled procedure to prevent stagnation and unfavourable temperatures. This guarantees optimal water hygiene.

The shut-off function lets the valve be opened and closed automatically or remotely via the app or building control technology (BMS). This prevents leaks, controls access and increases operational safety.

1.2 Structure of the GF Hycleen Flush & Shut-off valve

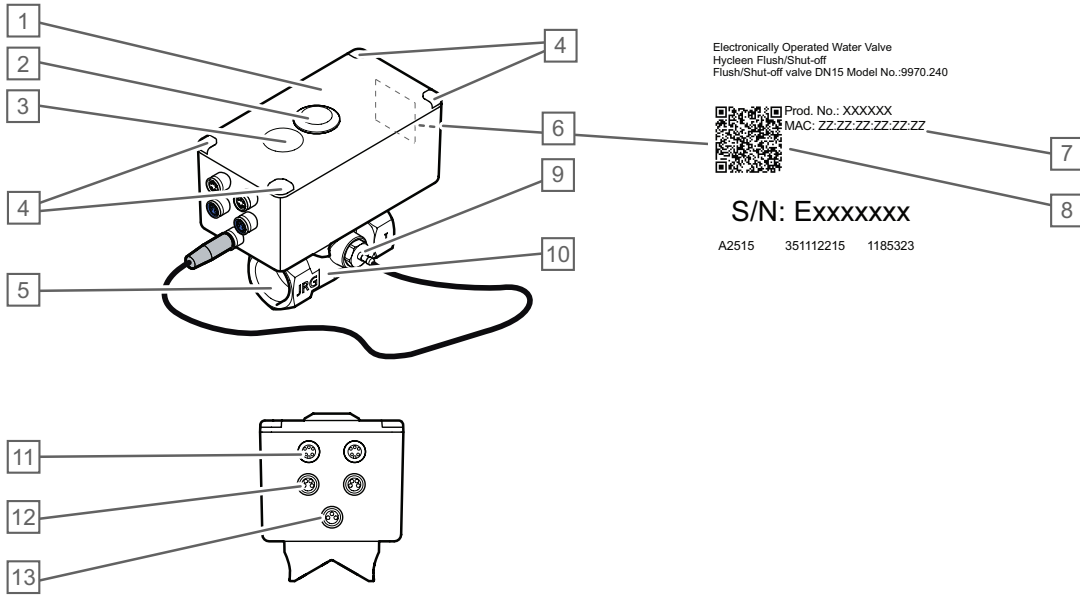

Item	Description
1	Controller/actuator
2	Protection cap for hexagon socket screws (open/close valve)
3	Interaction button
4	Information LED
5	Bottom part of the valve
6	Label with MAC address
7	Serial number (the name of the valve in the app)
8	QR code: Link to online documentation and instructions
9	Temperature sensor PT1000
10	Arrow to show the direction of flow
11	M8 connector for the external sensor connection
12	M8 connector for the power supply and bus communication
13	Connector for the temperature sensor PT1000

2 Components

EN

2.1 GF Hycleen Flush & Shut-off valve

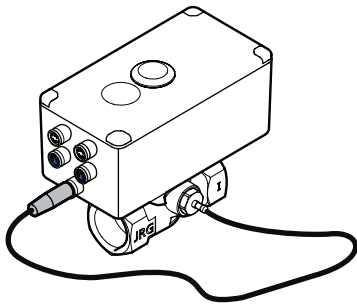

- Digital operation
- Material: Lead-free gunmetal (RG+), chrome-nickel steel, EPDM
- Flushes in accordance with time, temperature and consumption
- Working range (5 – 80°C)

CD0000638

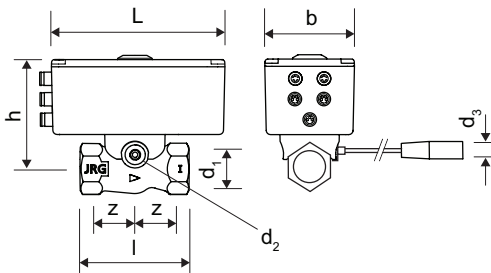

ZD0000196

JRG code	GF code	Uponor code	DN	Weight (kg)	d1, Rp (inch)	d2, Rp (inch)	d ₃	h (mm)	l (mm)	L (mm)	z (mm)
9970.240	351112215	1185323	15	0,800	1/2	1/2	M8	80	60	120	18
9970.320	351112220	1185324	20	0,960	3/4	3/4	M8	92	75	120	24

2.2 GF Hycleen power supply unit

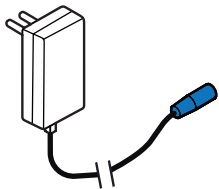

- For Hycleen Balance / Flush
- Power connection: 30 V DC
- Cable length: 1,5 m
- Can be extended up to a maximum cable length of 100 m and a maximum of 10 valves

CD0000839

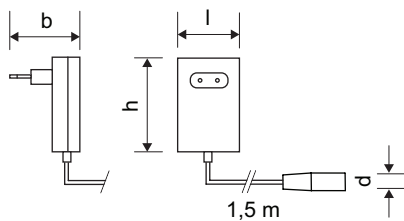

ZD0000135

JRG code	GF code	Uponor code	Voltage	Weight (g)	l (mm)	b (mm)	h (mm)	d	Version
9964.000	351112141	1162883	30V	0,280	48	35	77	M8	EU, UK, CH

2.3 GF Hycleen insulation

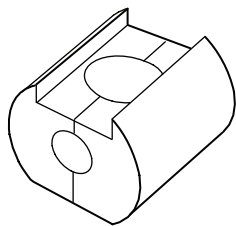

CD0000840

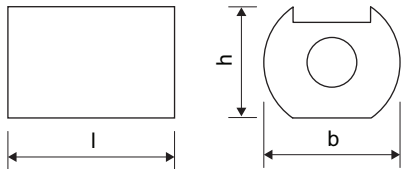

ZD0000134

JRG code	GF code	Uponor code	DN	Weight (kg)	l (mm)	b (mm)	h (mm)
9963.000	351112161	1162882	15/20	0,031	118	100	83

- For Hycleen Balance / Flush valves DN 15 and DN 20
- Self-closing, black, EPP

2.4 GF Hycleen power supply and communication cable



CD0000841

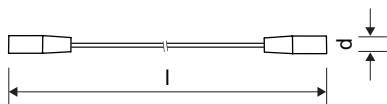

ZD0000133

JRG code	GF code	Uponor code	Weight (kg)	l (m)	d
9965.001	351112151	1162884	0,055	1,5	M8
9965.003	351112152	1162885	0,108	3	M8
9965.005	351112153	1162886	0,180	5	M8
9965.010	351112154	1162887	0,355	10	M8
9965.020	351112155	1185329	0,620	20	M8

- To connect Hycleen Balance / Flush components (valves, power supply unit) in series, including 2x M8 push/pull connectors, ROHS

2.5 GF Hycleen cable coupling



CD0000842

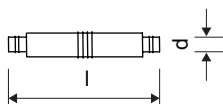

ZD0000131

JRG code	GF code	Uponor code	Weight (kg)	l (mm)	d
9966.002	351112156	1162888	0,015	47	M8

- To connect two Hycleen Balance / Flush cables, or to extend the power supply cable, with a pre-assembled push/pull connector
- Connector: M8

2.6 GF Hycleen BMS connection and bus extension

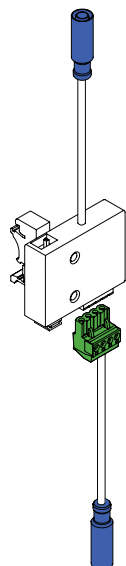

- To connect to the building management system through Modbus RTU and to expand bus communication with an additional power supply.
- Connection: 2-wire cable

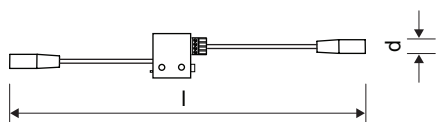

ZD0000146

JRG code	GF code	Uponor code	Weight (kg)	l (mm)	d (mm)
9966.000	351112157	1185326	0,30	336	11,5

2.7 GF Hycleen flow sensor

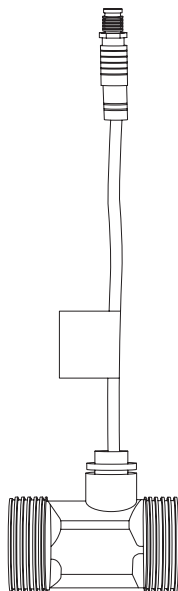

- Temperature: max. 90°C
- Nominal pressure: PN16
- Material: Brass
- Connection: Screw connection, cable connector M8

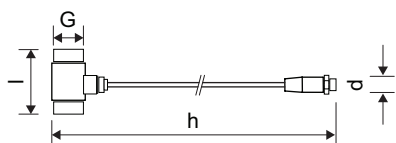

ZD0000147

JRG code	GF code	Uponor code	Weight (kg)	d1 (inch)	d	l (mm)	h (mm)
9950.020	351110772	1149751	0,25	1	M8	60	999

2.8 GF Hycleen AS temperature sensor

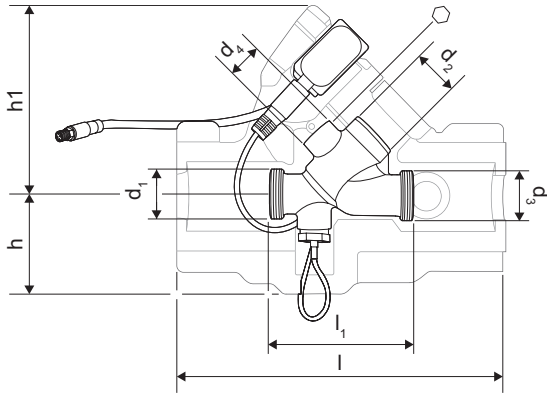

- Temperature sensor PT 1000 with valve
- Temperature: max. 90°C
- Material: Brass
- Connection: Screw connection, cable connector M8

JRG code	GF code	Uponsor code	DN	Weight (kg)	d1 G (inch)	d2 G (inch)	d3 G (inch)	d4 Rp (inch)	l (mm)	l1 (mm)	h (mm)	h1 (mm)
9951.015	351110535	1149707	DN 15	0,46	3/4	1/2	3/4	1/4	173	75	50	162
9951.020	351110661	1149732	DN 20	0,57	1	3/4	1	1/4	206	87	52	168

2.9 GF Hycleen temperature sensor

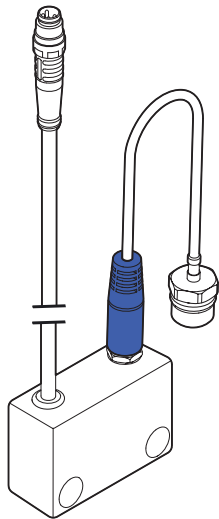

- Temperature sensor PT 1000
- Temperature: max. 90°C
- Connection: Cable connector M8

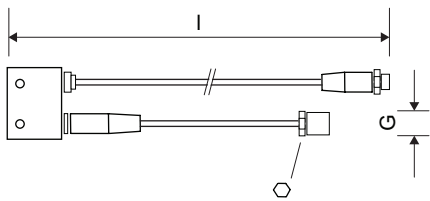

ZD0000148

JRG code	GF code	Uponsor code	Weight (kg)	G (inch)	l (m)	
9952.000	351110611	1149721	0,15	1/4	1	17

2.10 GF Hycleen extension cable for sensor



- Connection between sensor and controller
- Connection: M8

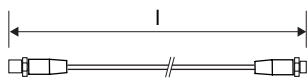

CD0000882

ZD0000150

JRG code	GF code	Uponor code	Weight (kg)	l (m)
9943.005	351110662	1149733	0,011	5

2.11 GF Hycleen drain monitoring sensor

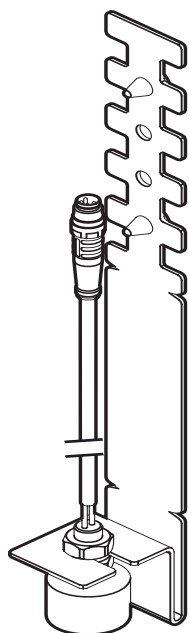

- Includes: Float switch, holder, cable, binding ties
- Connection: Connector M8

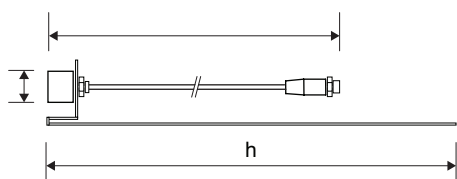

JRG code	GF code	Uponor code	Weight (kg)	l (mm)	l1 (mm)	h (mm)
9953.000	351110763	1149750	0,16	1000	24	250

3 Example system

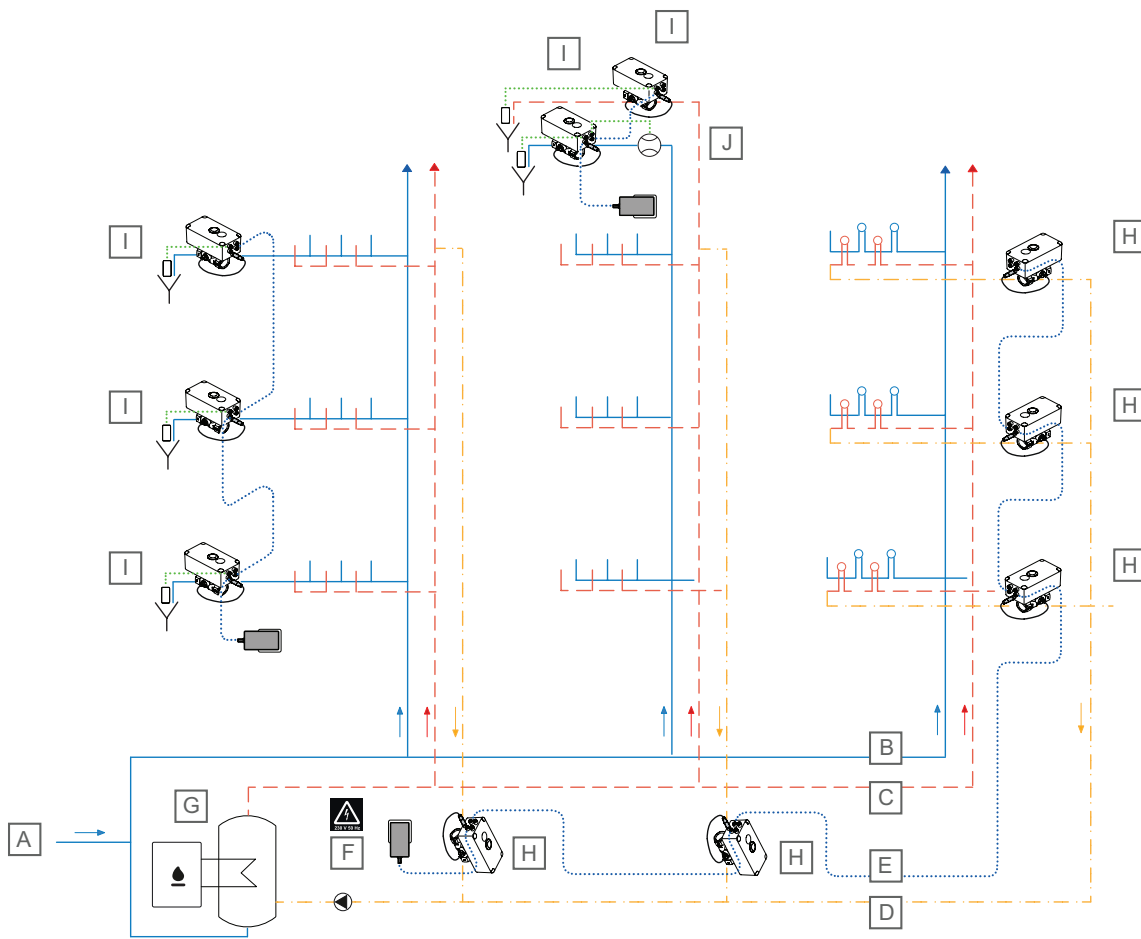

SD0000432

Item	Description
A	Cold water supply
B	Cold water line
C	Hot water line
D	Circulation line
E	Power and communication line
F	Power supply unit
G	Hot water supply
H	GF Hycleen Balance balancing valve
I	GF Hycleen Flush & Shut-off valve with Hycleen temperature sensor
J	Hycleen flow sensor

3.1 Install the flow sensor to flush depending on volume

3.2 Install the flow sensor to flush depending on consumption

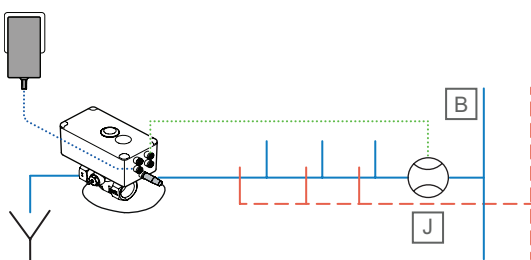

SD0000434

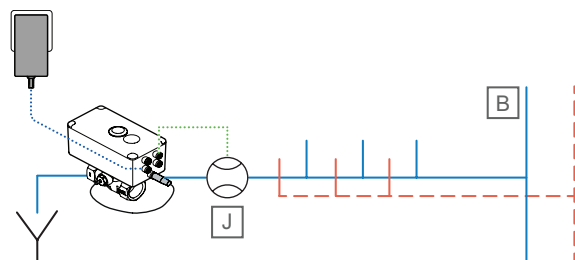

SD0000433

4 Installation

EN

Note

The controller is pre-programmed in accordance with the type and size of the valve. Do a careful check of whether the colour of the label on the controller aligns with the colour of the protection cap of the valve:

The GF Hycleen Flush can be installed anywhere on the line. For revision purposes, install the valve in a position with access. We recommend that the GF Hycleen shut-off units (JRG code 8339) and screw connection 8724 are installed.

The arrow on the valve body must align with the flow direction of the water.

Use the Hycleen insulation to keep heat loss to a minimum.

For Hycleen Flush drain dimensions, refer to the chapter "Flushing capacity curves". The dimensions of the drain must prevent backing-up. If there is a risk of backing-up, install a backflow preventer.

For additional protection, we recommend the installation of a Hycleen monitoring sensor

To prevent damage to the valve, keep the protection cap on the upper insert during installation.

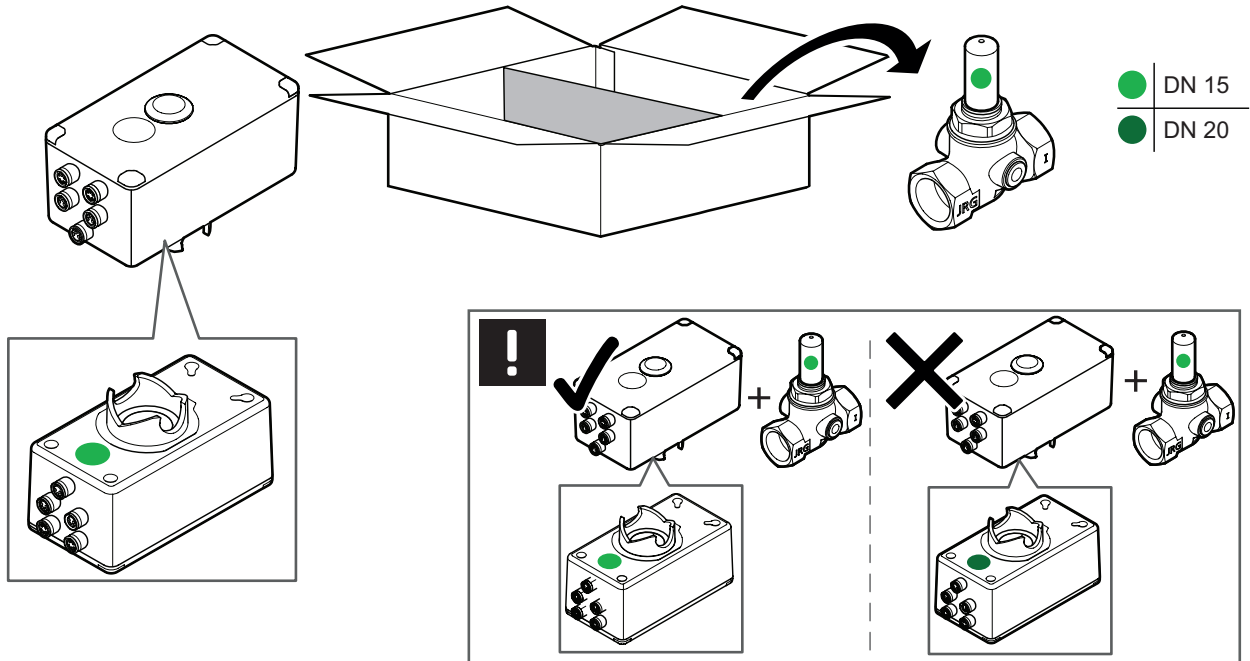

4.1 Install the controller

Note

For revision purposes, there must be a distance of 8 cm between the controller and the nearest surface.

Flushing

Before the Hycleen Flush is installed, flush the lines thoroughly.

Seals

Only AFM 34 seals are permitted. Do not apply oil or grease to the seals.

Soldering

If solder connections are used, do not install the Hycleen Flush valve during the soldering procedure. If the valve becomes too hot, this can cause damage.

Have the controller for the valve prepared. Do a check of whether the colour coding on the label below the controller housing aligns with the colour coding on the cap. The size of the valve is also specified on the controller label.

1. Remove the cardboard protection cap.
2. Connect the controller to the valve. The tooth system in the controller must align with the tooth system of the spindle. If necessary for this alignment, turn the controller slightly.

Note

Make allowance for the fact that a drain will be installed after the last flushing valve. The minimum distance to the drain and the maximum flow rate must be in dimensions that are in accordance with the country-specific regulations.

Note

The valve is supplied with a closed spindle to make the installation of the controller easier.

If the installation is still not correct, continue as follows:

- a. Supply power to the controller for a few seconds (connect the power supply unit to a 230 V power supply).
- b. The controller turns slowly. Put the controller on the valve.
- c. The tooth systems of the controller and the spindle are aligned.
- d. Disconnect the power supply unit from the 230 V power supply

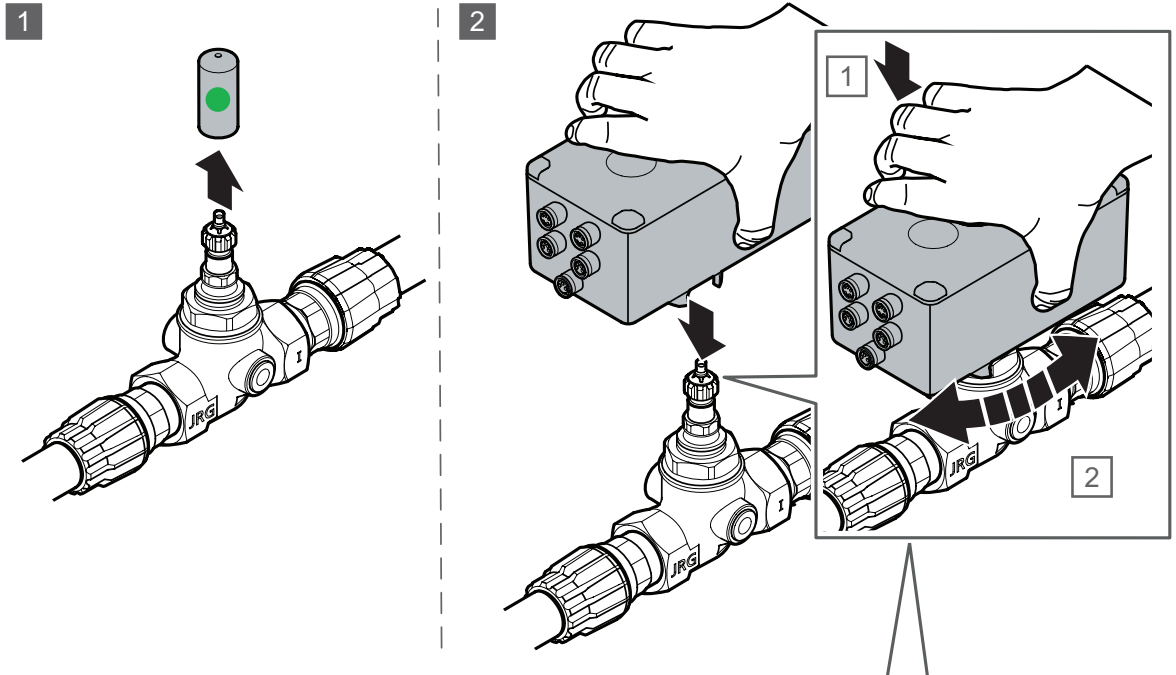

Install the controller exactly on the valve stack until it makes a click. The controller can be installed in either direction

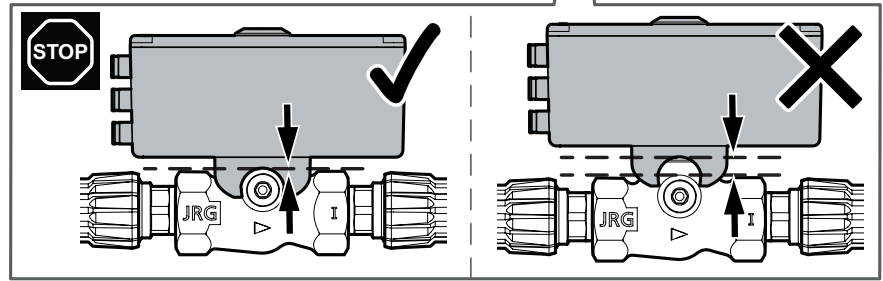

4.2 Temperature sensor

Attach the connector for the temperature sensor onto the controller bush with screws. If insulation is to be used, drill through the insulation first to put the connector in the insulation and then connect the connector to the valve. The M8 connector on the other end of the cable is put into the lower bush on the controller (→ makes a click).

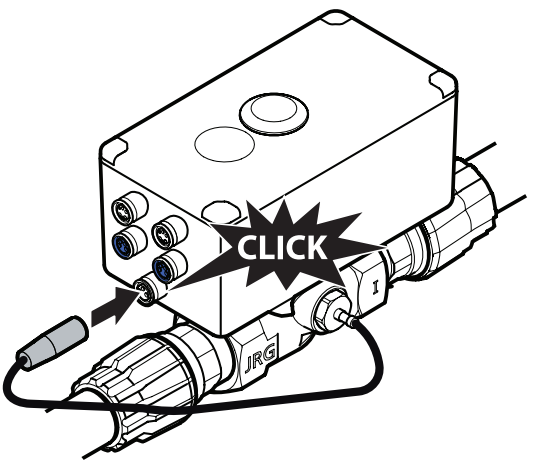

4.3 Cabling in series

- Note**
Components that are not permitted can cause malfunctions!
- Note**
To remove the cable, only pull the blue connector, not the cable.
- Note**
You must connect all components in series (one after the other, connected to one another).
It is not permitted to connect the components in parallel or in a star shape!
It is not permitted to do modifications to the components and cables!

The connecting cables contain four wires: two to supply power and two to transmit signals. The two ends of the cable have the same female M8 connector and are twist-proof. The M8 connector holds the connection in place reliably, even in harsh conditions.

4.4 Cable connection between the controllers

Note

Never connect or disconnect the cable when the power supply is active!

1. Connect the first connector of the connecting cable to one of the two M8 bushes on the controller (→ makes a click).
2. Connect the other connector of the connecting cable to one of the two M8 bushes on the next controller (→ makes a click). It is not relevant which of the two lower M8 bushes is used for this purpose.

Connect all other Hycleen Flush controllers with the same procedure.

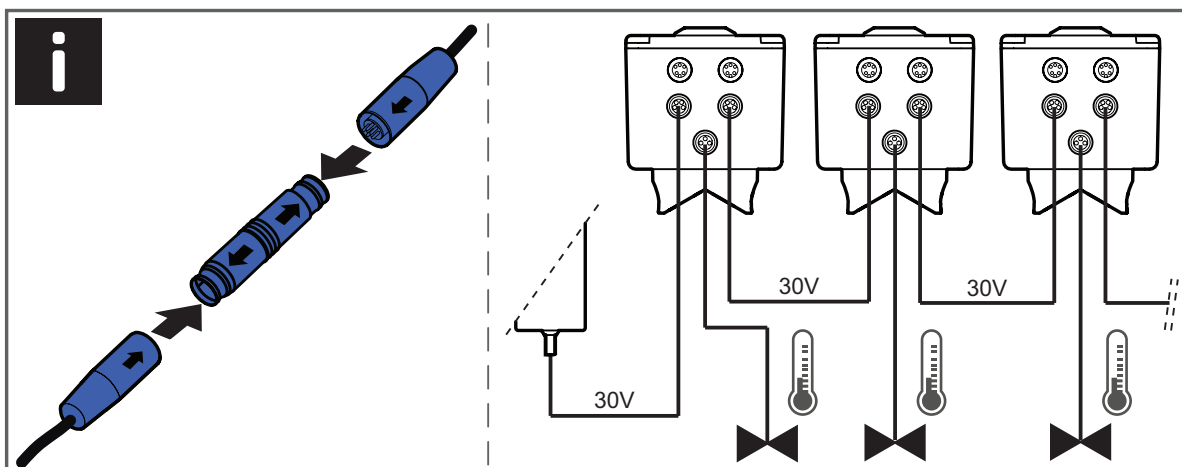
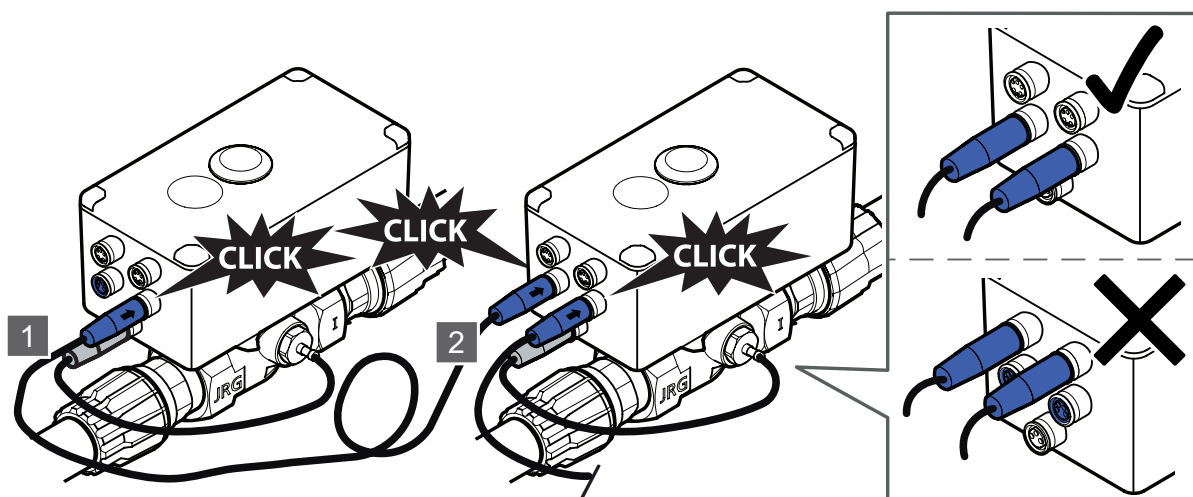

Note

The connecting cables can be extended with a Hycleen coupling. Obey the maximum length of the cables: See the instructions that follow.

Note

Maximum length of the sum of the connecting cables in a chain attached to a power supply unit: 100 m.

Maximum number of controllers in a chain that are attached to a power supply unit: 10 pieces.

If the building contains more than 10 valves and/or 100 m of cable, use an additional power supply unit.

Note

Risk of malfunction due to inadequate installation.

If the M8 connector is not put into the bush correctly, the connector can become loose. This can cause a loss of functionality! Make sure that all the connectors of the connecting cables are correctly connected.

Note

Never connect or disconnect the cable when the power supply is active.

Note

The cables can be put directly on the circulation line. If necessary, the cables can be put on the outside of the insulation. Use binding ties that are resistant to temperatures up to 90°C.

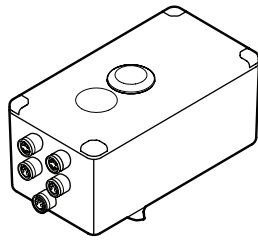

max. 10x

max. 100 m

EN

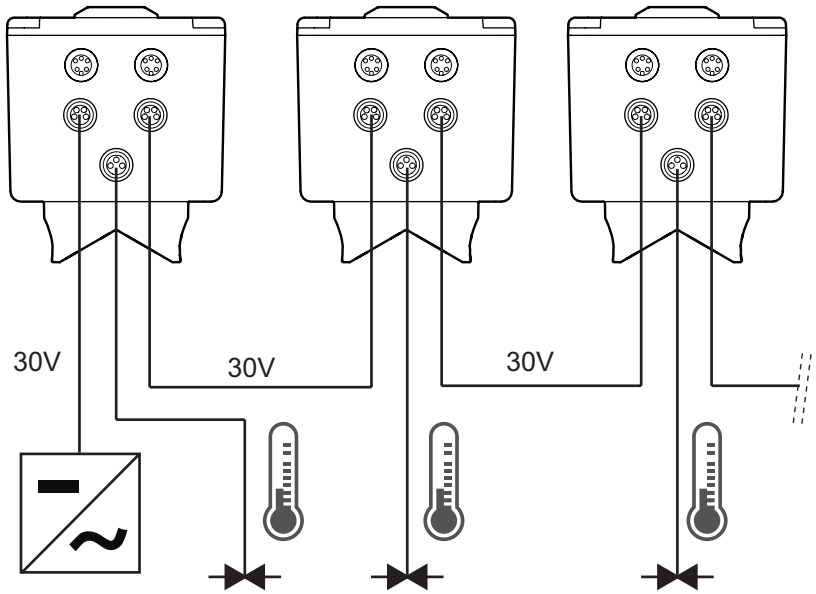

5 Commissioning

EN

5.1 Electrical connection

Note
 Connect only the first valve to the power connection. The downstream valves are then supplied with power via the connecting cables.

As soon as the valves are connected in series, the first valve can be connected to the power connection with the power supply unit and energised for commissioning.

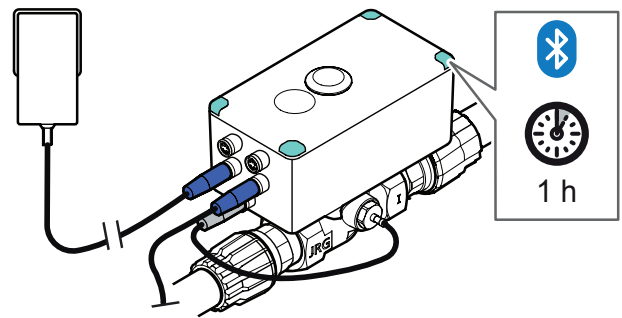
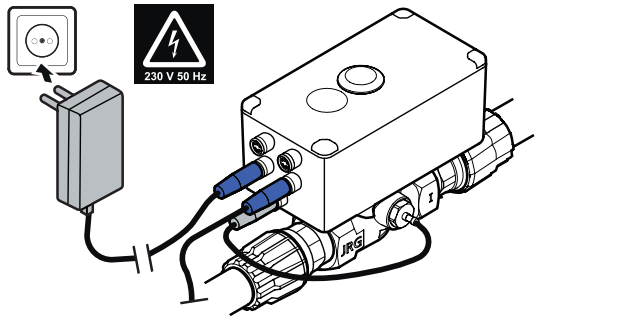

5.2 Interaction button

The button can be used to do various actions:

	ON	OFF	reboot	reset	Standard operation, no action
	< 5 s	> 5 s < 10 s	> 10 s < 15 s	> 15 s < 20 s	> 20 s

5.3 Commissioning / Bluetooth connection

Connection to the app



Note

As part of the first flushing procedure, do a check to make sure that the opening of the valve aligns to the direction of flow. Then do a check of the flushing capacity (see diagram in the chapter "Technical data").

For the Bluetooth connection, download the Hycleen Balance / Flush app to your smartphone. Continue as follows:

1. Push the button for < 5 seconds.
2. Start the app and select a valve. If no valve is shown, click "Available".
3. Enter the Bluetooth password for the connection: Select the valve
4. and enter **123456**. Click OK.
5. The related Hycleen valve is connected.
6. Commissioning screen, input: Name of the valve, language etc. The Modbus address is given automatically at random. Click OK.
7. Home screen: When this screen is shown, the valve is commissioned and the next valve is supplied with power. The next valve can be commissioned as the app goes back to the home screen that shows the list of valves.
8. Enter the flushing parameters. Enter the opening degree of the valve in the app. Do a check that the drain is correctly installed and is large enough for the intended flow rate.

Do the procedure again for each controller in the network chain.

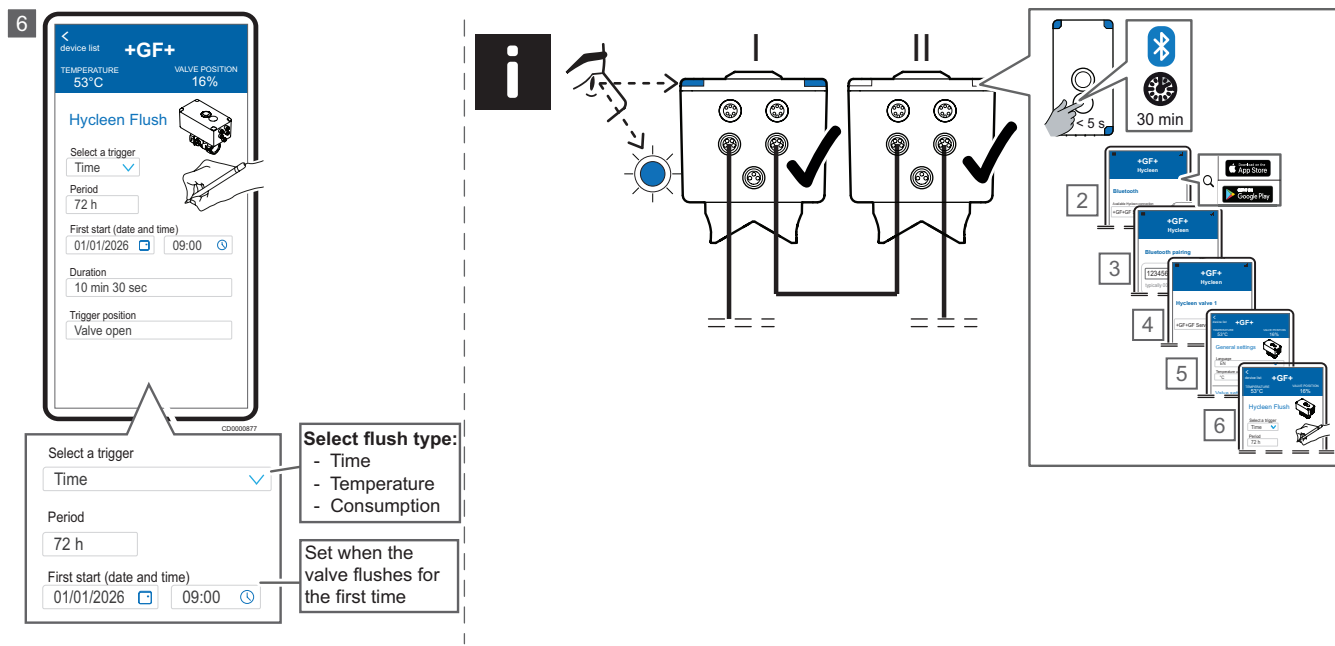
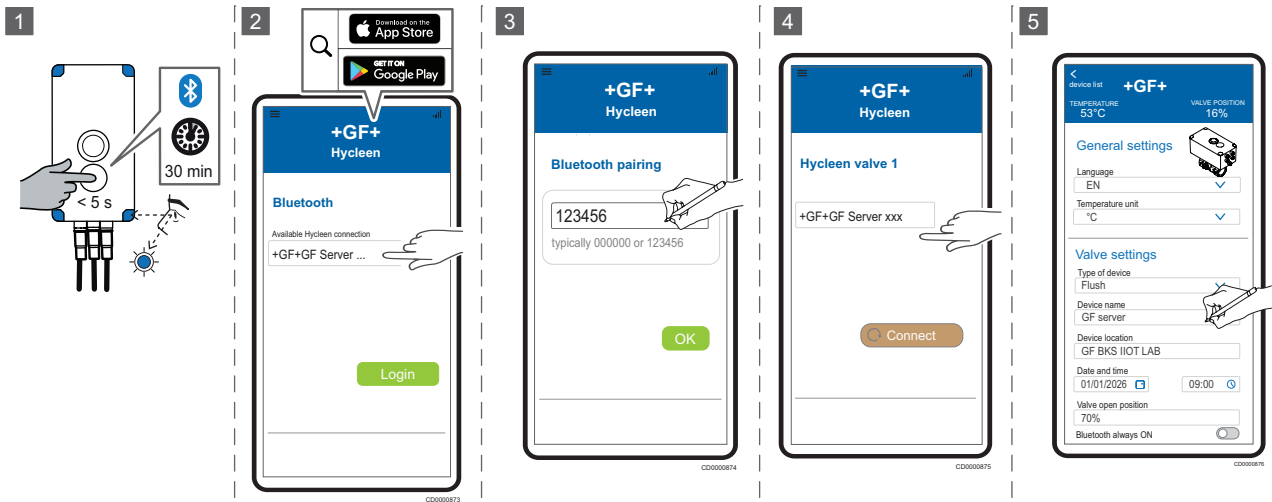

Enter the settings for the flushing procedure

Note
 During the commissioning procedure, enter the maximum opening of the valve for flushing procedures in the app ("Settings"). Do this in accordance with the diameter of the drain pipe (see also diagram "Flushing capacity"). During the first flushing procedure, always do a check to make sure that there are no problems. If water is released from the drain, decrease the opening degree (A) of the valve.

5.4 LED coding

If a valve is connected to the power supply, the LEDs come on. The frequency or light colour shows the visual information that follows:

Colour	LED	Info
Green	Flashes 1x every 30 seconds	Difference between the temperature setpoint and average temperature in the last 24 hours: +/- 2°C
	Flashes 2x every 30 seconds	Difference between the temperature setpoint and average temperature in the last 24 hours: +/- 2°C to +/- 5°C
	Flashes 3x every 30 seconds	Difference between the temperature setpoint and average temperature in the last 24 hours: >+/- 5°C
Red	Flashes	Error
Blue	Flashes	Bluetooth connection with smartphone/tablet
Light green	Constant	Flushing procedure in progress
Light blue	Constant	Start, calibration
	Flashes	Maintenance

6 Connection to building control technology (BMS)

Use the GF Hycleen BMS connection and bus extension to integrate the Hycleen Flush valves into the Building Management System (BMS) (see cable no 1 in the wiring diagram that follows). Install the GF Hycleen BMS connection and bus extension between the power supply and the first valve. The power and communication cables can be used to communicate with all valves connected to the bus.

If more than 10 valves are to be connected to the bus, extend the bus between the tenth and eleventh valve. At this location, another cable no 1 and the associated cable no 2 are connected. Connect another power supply (see wiring diagram that follows).

Max. number of valves on the same bus: 245 valves

RS-485 interface: The valve has a receiver impedance of 1/8 unit load.

For BMS programming, see separate document, GF Hycleen Modbus Register.

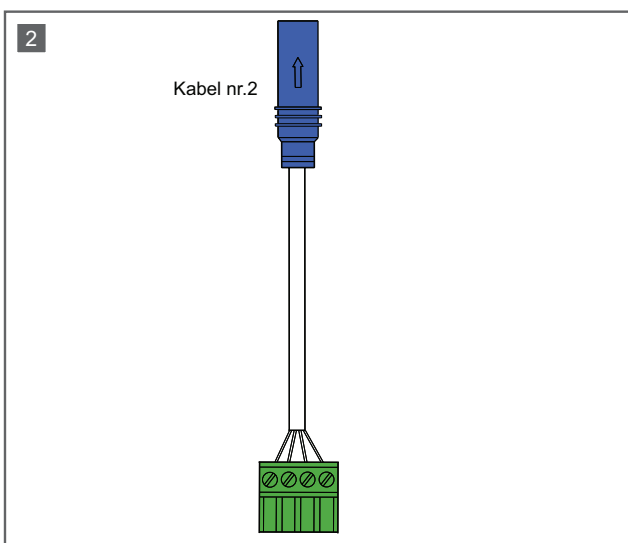
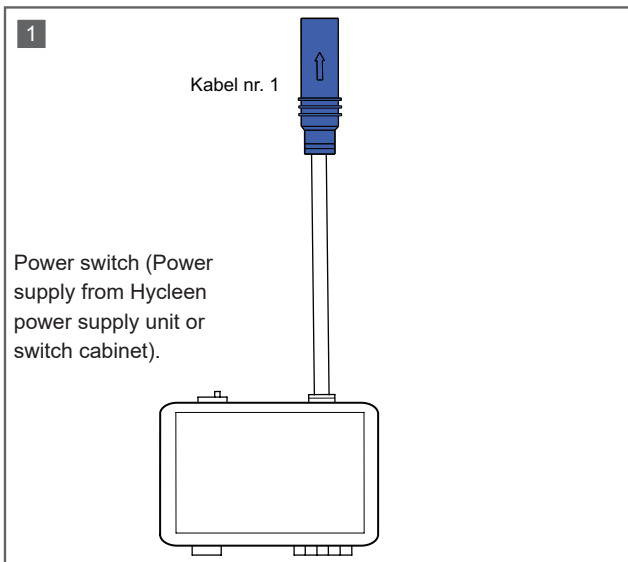

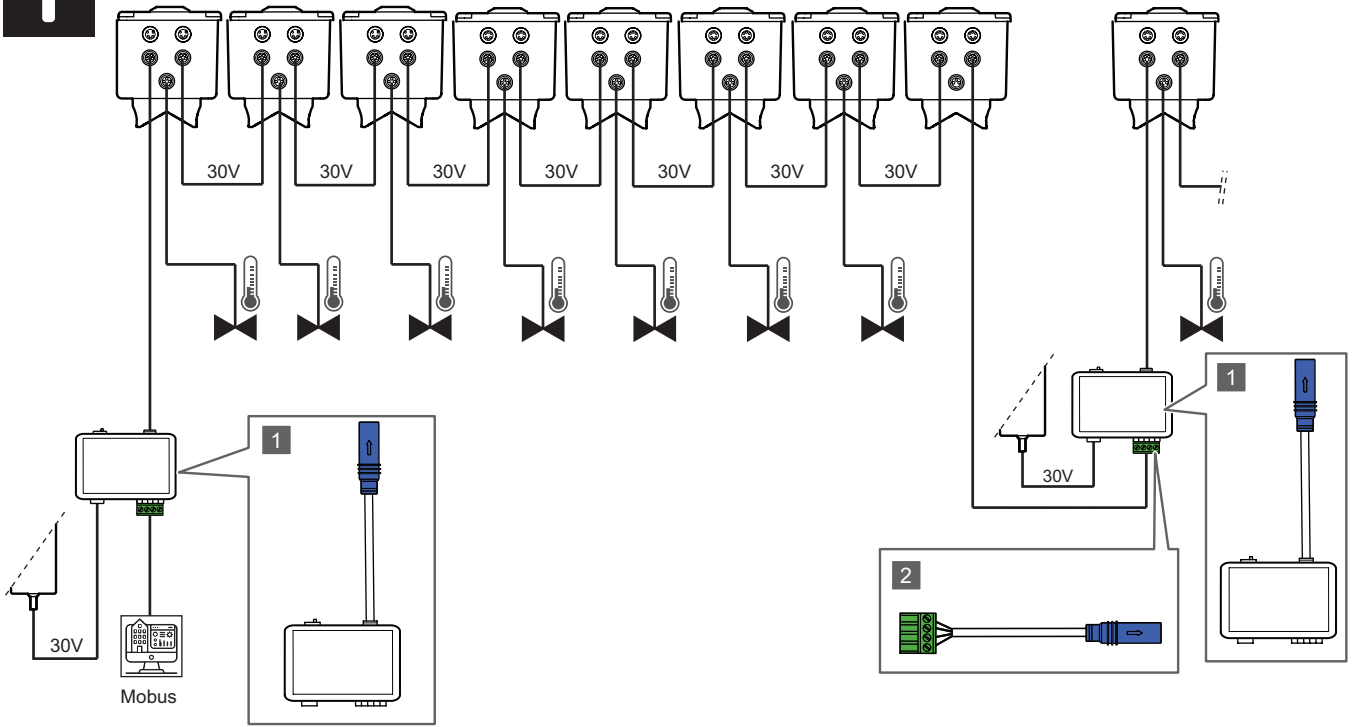

7 Technical data

Maintenance

Do a check of the seals of the GF Hycleen Flush yearly. After a long power failure, do a check of the valve and manually close the valve if necessary.

Customer Service hotline: +41 61 975 23 77,
info.jrg.ps@georgfischer.com

Checks

Yearly check of the seals of the GF Hycleen Flush valve.



Note

Do not use the GF Hycleen Flush valve in a water system of the types in patents EP 1 845 207 B1 and DE 10 2006 017 807 B4 without the permission of the holder of patents EP 1 845 207 B1 and DE 10 2006 017 807 B4.



Disposal

System components of the GF Hycleen Flush valve can be discarded in accordance with local regulations.

Item	Value
Housing:	Lead-free gunmetal (RG+)
Tappet/seat:	Stainless steel
Valve cone:	RG+ / EPDM
Seals:	EPDM
Intended for operation with:	Medium drinking water
Dimensions:	DN 15/20
Water temperature:	1 – 80°C
Control accuracy:	< ± 1°C
Max. operation temperature:	90°C
Max. operating pressure:	10 bar
Ambient temperature:	0 – 45°C
Power supply:	30 V DC
Actuator, stroke:	Stroke 5/7 mm
Valve delivery state:	0% open
Operating voltage:	30 V DC
Open/close power consumption:	5 W
Idle power consumption:	1 W
Close/open time:	approx. 15 s/20 s
Housing class:	IP 44
BLE operating frequency:	2402 ~ 2480 MHz
BLE peak:	2,2 dBm
RS-485 interface	1/8-unit-load

8 Error messages and troubleshooting

EN

You can see the error messages and troubleshooting in the Hycleen App, in the Notifications chapter.

8.1 Error categories

Error code	Description	Category	
xx0xxx	System		
	300001	Initialisation necessary	Info
	300002	Device initialisation started	Notification
	300003	Device initialisation completed	Notification
	100006	Controller communication error	Error
	100008	PT 1000 not connected	Error
	200009	Drive defective	Fatal error
	100011	Unknown error -> do a restart of the valve	Error
	300013	Memory almost full	Info
	300014	Memory full, historical data deleted	Info
	100015	Sensor1 (4 – 20 mA) not connected	Error
	100016	Sensor2 (4 – 20 mA) not connected	Error
	xx1xxx	Network	
		301002	Bluetooth connection made
301003		Bluetooth connection stopped	Info
xx2xxx	Configuration		
	602001	Max. position changed	Change log
	602004	Min. position changed	Change log
	302039	Calibration started	Info
	102040	Calibration not completed	Error
	302041	Calibration done	Info
xx5xxx	Updates		
	305003	SW update started	Info
	105004	SW update download not completed	Error
	305005	SW update downloaded	Notification
	405006	SW update in progress	Wait
	305008	SW update completed	Info
	105007	SW update not completed	Error
	305001	Current SW version	Info
	305002	Current FW version	Info
	xx6xxx	Maintenance	
606001		Maintenance day changed	Change log
606002		Maintenance start time changed	Change log
306003		Maintenance process started	Notification
306004		Maintenance process completed	Notification
306020		Device is at life cycle 55000	Info
306021		Device is at life cycle 60000, replace the device	Info

8.2 Troubleshooting

Error code	Error description	Description
100006	Controller communication error	Contact Technical Support if the valve does not operate or if the problem occurs more than once a day, otherwise the valve will only do a restart.
100008	PT 1000 not connected	Do a check to make sure that the temperature sensor is correctly connected to the controller. Do a restart from the app If the valve still does not operate, the cable can have damage or the sensor can be defective. Replace the sensor.
200009	Motor defective	Do a check to make sure that the controller is correctly installed on the valve. Start the calibration process again from the app ("Settings"). Push and hold the interaction button for 15 seconds or set the controller to the factory default settings via the app ("Settings"). If the problem continues, contact technical support or replace the controller.
100011	Unknown error	Start the controller again
100015	Sensor1 (4 – 20 mA) not connected	Occurs when the sensor is configured in the app but is not connected. Remove the configuration from the app if the sensor is not available. Otherwise: Do a check to make sure that the sensor is correctly connected to the controller. Start the app or push the interaction button. If the valve still does not operate, the cable can be damaged or the sensor can be defective.
100016	Sensor2 (4 – 20 mA) not connected	Occurs when the sensor is configured in the app but is not connected. If no sensor is available, remove the configuration from the app. Otherwise: Do a check to make sure that the sensor is correctly connected to the controller. Start the device again from the app or push the interaction button. If the valve still does not operate, the cable can be damaged or the sensor can be defective.
301003	Bluetooth connection stopped	If the valve still does not operate, the cable can be damaged or the sensor can be defective. If the valve still does not operate, the cable can be damaged or the sensor can be defective.
102040	Calibration not completed	Do a check to make sure that the controller is correctly installed on the valve. Start the calibration process again from the app ("Settings"). Push and hold the interaction button for 15 seconds or set the valve to the factory default settings via the app ("Settings"). If the problem continues and the valve is stuck: Remove the controller and release the valve spindle lock with a spanner. If the problem continues, replace the controller.
302041	Calibration done	

Error code	Error description	Description
105004	SW update download not completed	Try to upload again. If the upload is not completed again, continue as follows: Download the software again from the Internet and try again.
305005	SW update downloaded	If the valve still does not operate, contact Technical Support.
105007	SW update not completed	Start the controller again either via the app or the interaction button.
305001	Current SW version	If the valve still does not operate, contact Technical Support.
308010	T_{\min} (mean value) for 24h below the threshold	Do a check of the valve opening degree. If the valve is fully open, the problem is somewhere else in the system. Do a check of the hot water temperature. Do a check of the circulation pump. Do a check to make sure that the valves on the circulation line are closed. Do a check to make sure that there is air in the circulation lines. Do a check of the backflow preventer. It is possible that cold water can go back into the warm water circuit.
-	The valve is not supplied with power (no indicator light, no flash, no response).	During the commissioning procedure: Do the commissioning procedure for the first/previous valve. The valve will not supply current to the next valve until it is fully operational. Do a check of the connection setting in the app settings: The last valve in the chain must have connection 1, the other valves must have connection 0.
-	The valve does not receive current.	Do a check to make sure that the connector is plugged into this valve and the previous valve. Do a check of the connection on the previous valve; it must be 0. Do a check of the power supply. Do a check of the wiring for damage.
-	The valve does not move and the indicator light does not come on.	Do a check of the power supply. Do a check of the cable for damage.
-	I cannot connect my smartphone/tablet to the valve via Bluetooth.	Do a check of your smartphone/tablet Bluetooth settings/permissions.
-	The valve does not flush.	Do a check of the drain monitoring. Do a check of the flushing parameters in the app.
-	I flush too much water.	Adjust the flushing opening degree in the app.
-	How can I import the CSV file into Excel?	Use the CSV function: Open Excel, Data > From Text/CSV > Select the necessary file.
-	What do I do after the update if it still does not work?	Do a restart of the valve. Do a check of the application parameters in the app.

9 Flushing capacity curves

9.1 Flushing capacity of GF Hycleen Flush valve DN 15

EN

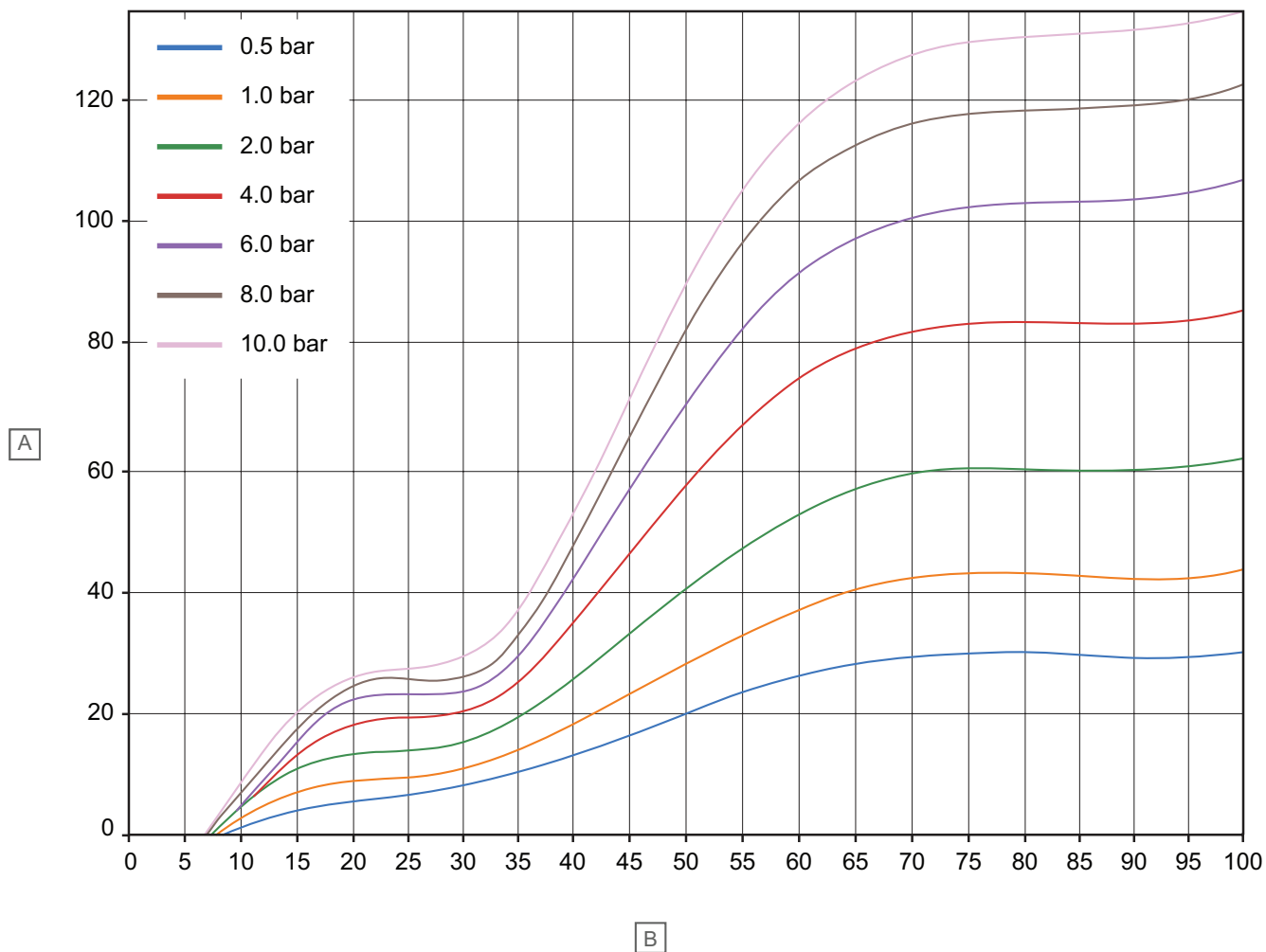

Item	Description
A	Flow [l/min]
B	Opening degree [%]

9.2 Flushing capacity of GF Hycleen Flush valve DN 20

EN

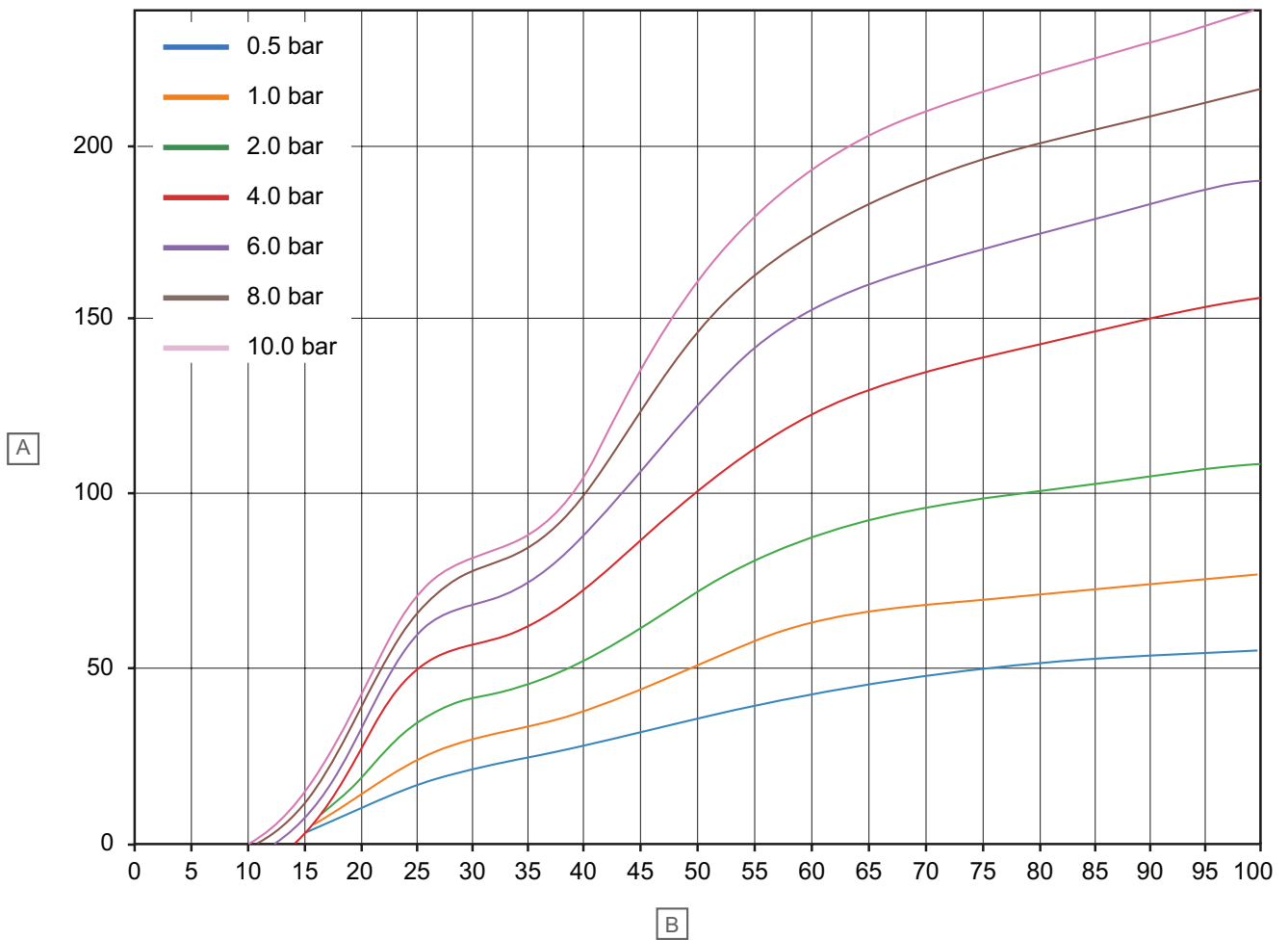

Item	Description
A	Flow [l/min]
B	Opening degree [%]

10 Regulatory conformance

The GF Hycleen Balance and GF Hycleen Flush & Shut-Off wireless products obey the guidelines that follow:

- CE
- UKCA
- EAC (869 MHz wireless version only, not 868,3 MHz version)

EU/UK Declaration of Conformity

GF hereby declares that the wireless equipment GF Hycleen Balance and GF Hycleen Flush & Shut-Off obey the relevant EU harmonisation legislation. ¹⁾

The full text of the EU/UK Declaration of Conformity is available on the Internet at:
<https://www.uponor.com/doc/1162345>



1) The certification and conformity marks indicated are on the corresponding GF product.

Notes:

This device obeys part 15 of the FCC regulations (US Federal Communications Commission). Operation is subject to the two conditions that follow:

1. This device must not cause harmful interference.
2. This device must accept any interference, including interference that can cause undesired operation.

Note: A test of this device was done in accordance with part 15 of the FCC regulations and obeys the limits for Class B digital devices. These limits are designed to provide sufficient protection against harmful interference in residential buildings. This device supplies, uses and can radiate high-frequency energy. If the device is not installed and used in accordance with the instructions, it can cause harmful interference to radio communications. But, there is no guarantee that interference will not occur in a particular installation. If this device causes interference to radio or television reception, which can be shown if the equipment is set to on and then set to off, the user can try to correct this with one or more of the measures that follow:

- Align the receiving antenna again or change its routing.
- Increase the distance between the device and the receiver.
- Connect the device to a socket that is not connected to the same circuit as the receiver.
-

This device contains licence-exempt transmitters/receivers that obey the Canadian Innovation, Science and Economic Development Authority's licence-exempt RSS.

Importer for the United Kingdom:

GEORG FISCHER BUILDING FLOW SOLUTION Ltd Paradise Way, Coventry CV2 2ST, United Kingdom

Please note that changes that are not expressly approved by the regulatory authority can void the permission for the user to operate the equipment.



Georg Fischer JRG AG

Hauptstrasse 130
4450 Sissach, Switzerland

1188136_v1_01_2026
GF / JLI_ASP

Georg Fischer reserves the right to make changes, without prior notification, to the specification of incorporated components in line with its policy of continuous improvement and development.



www.gfps.com