

Fact Sheet Stormwise Vortex

Effective solution for stormwater purification

Removal of pollutants from stormwater

The GF Stormwise Vortex is used to purify stormwater from coarse dirt. The Vortex can be used as a stand-alone solution or as a pre-treatment unit upstream of the following systems:

- ponds and wetlands
- filter chambers
- infiltration and retention systems

One chamber separates sinking particles as well as floating debris and oil.

A Vortex is used if a high water flow is expected and a moderate level of purification is needed.

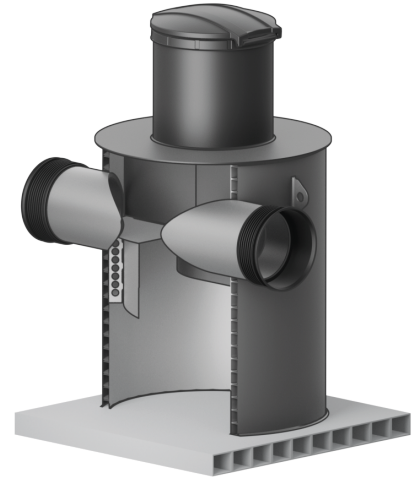

Compliant with local regulations

Accelerates your project timeline and simplifies approvals by authorities.



Complete and prefabricated

Saves up to 50% installation time and reduces risks for installation errors.



Compact and robust

Saves up to 50% space and allows flexible placement, even under traffic load.



Convenient and accessible

For reliable operation and easy maintenance.

Technical data

Application	Purification of stormwater
Material (body)	PE 100
Color	Black (outside), white (inside)
Inner diameter (ID)	1200 - 1350 mm
Height (H)	1900 - 2850 mm
In/out diameter (DN)	400 - 1200 mm
Weight	350 - 1800 kg
Inlet position below ground level (h1)	700 - 1650 mm
Outlet position below ground level (h2)	700 - 1650 mm
Inlet position above base (h3)	1200 mm
Functional flow rate	30 - 600 l/s
Maximum flow rate	160 - 3000 l/s
Sediment volume	352 - 3167 l
Oil volume	133 - 2846 l

Approvals	IKT seal pending
Standards	EN 13476 EN 13598 DWA-A 102-2

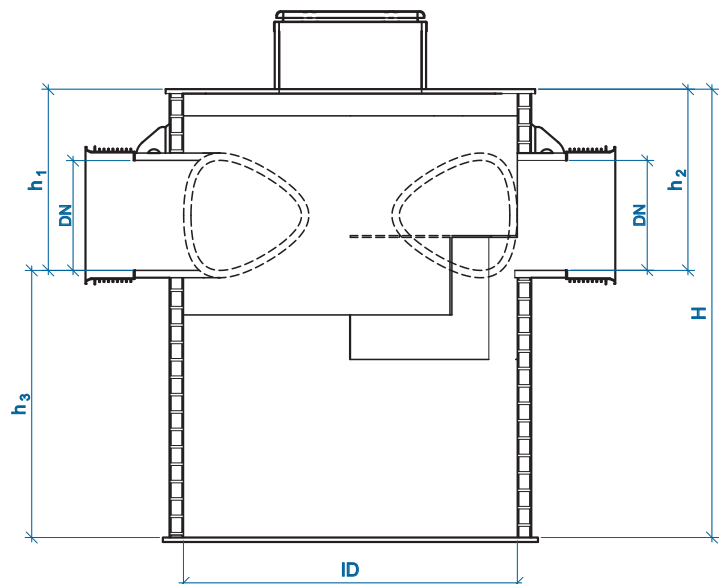

Components

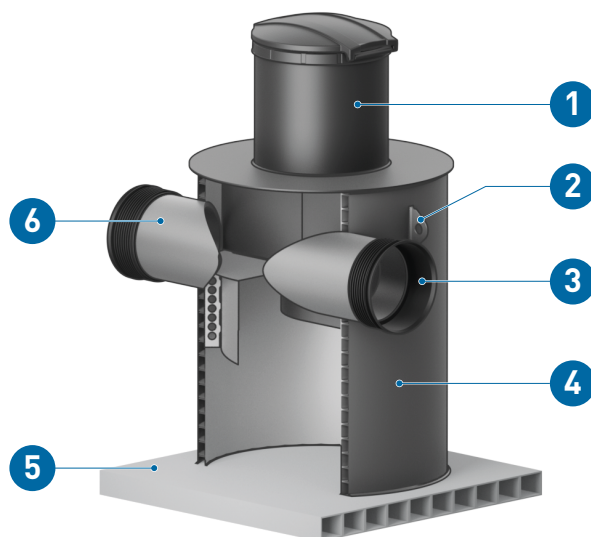

Pos.	Designation	Pos.	Designation
1	Vortex top	4	Body
2	Lifting yoke	5	Base
3	Inlet	6	Outlet

Customizable components

- Chamber size
- Riser height
- Chamber top types

Chamber top types and sizes (selection)

Type A	Type B	Type C	Type D	Type E
ø860/800 With safety gate	600x600 metal 800x800 metal	ø600 GE 40tn ø630 GE 40tn	ø630 GE 40tn ø800 GE 40tn	ø600 no lid ø800 no lid ø1000 no lid
				

Optional components

- Oil absorber
- Alarm system

Item number

Item no.	Description
35001139922	Vortex



Speak to an expert
 Discover how Stormwise solutions can transform your stormwater management.
www.gfps.com/stormwise

The information and technical data (altogether "Data") herein are not binding, unless explicitly confirmed in writing. The Data neither constitutes any expressed, implied or warranted characteristics, nor guaranteed properties or a guaranteed durability. All Data is subject to modification. The General Terms and Conditions of Sale of Georg Fischer Piping Systems apply.

