

# Uponor Clean II Treatment Plant

Installation and operation manual

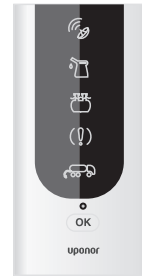

# Contents

1. Overview .....	3
2. Planning of clean treatment plants.....	4
3. Installation and dimensional drawings.....	5
4. Technical information.....	6
5. Installation.....	7
6. Setting up the wireless alarm system .....	12
7. PlantCare .....	13
8. Operation .....	14
9. Operating principles.....	17
10. Maintenance .....	20
11. Instructions for sludge emptying .....	21
12. Sampling.....	22
13. Malfunction.....	23

## Attachments

Declaration of Performance .....	25
Contact information .....	27
Clean Flocculation Chemical Safety Data Sheet .....	28
Logbook .....	38

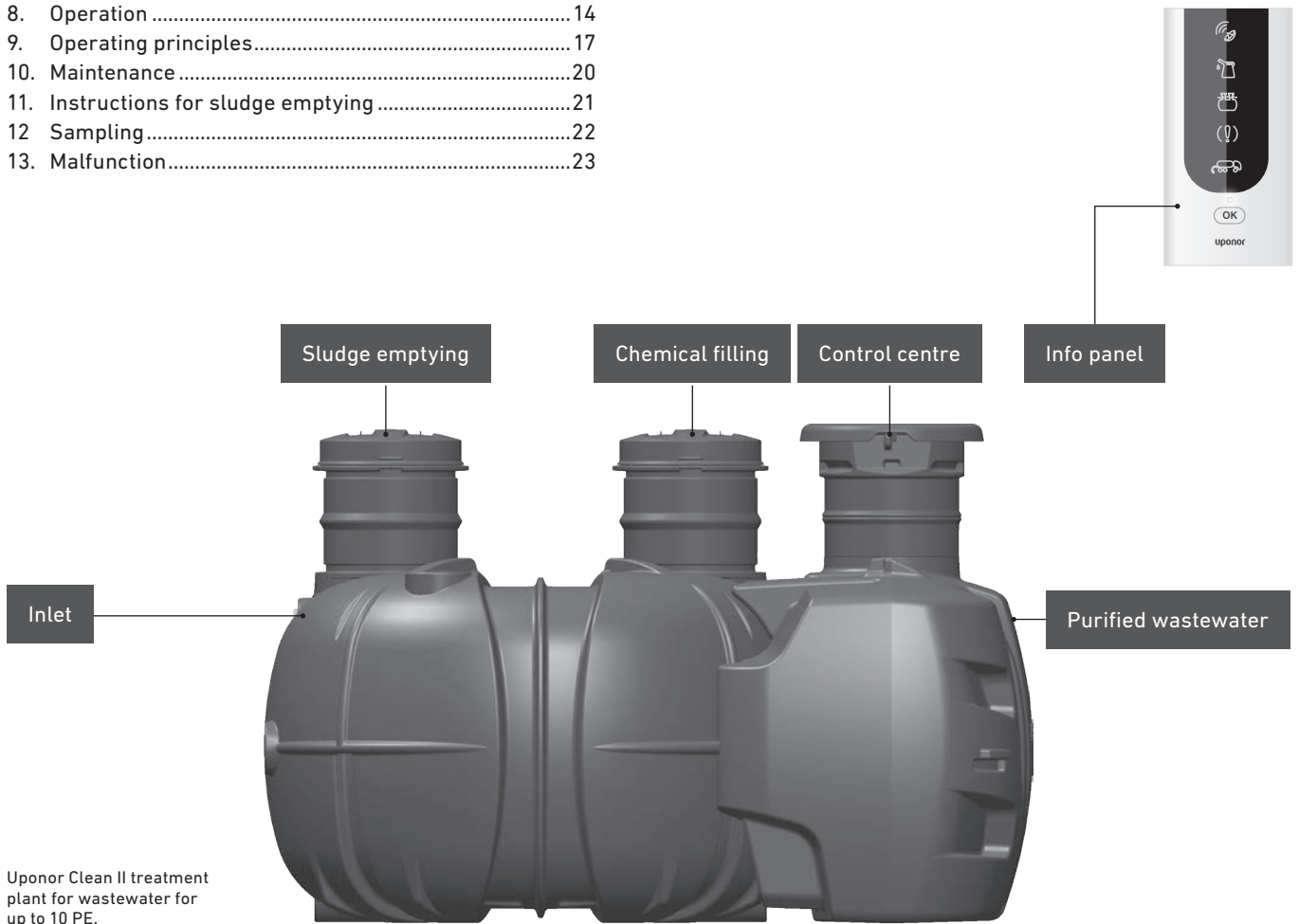

Uponor Clean II treatment plant for wastewater for up to 10 PE.

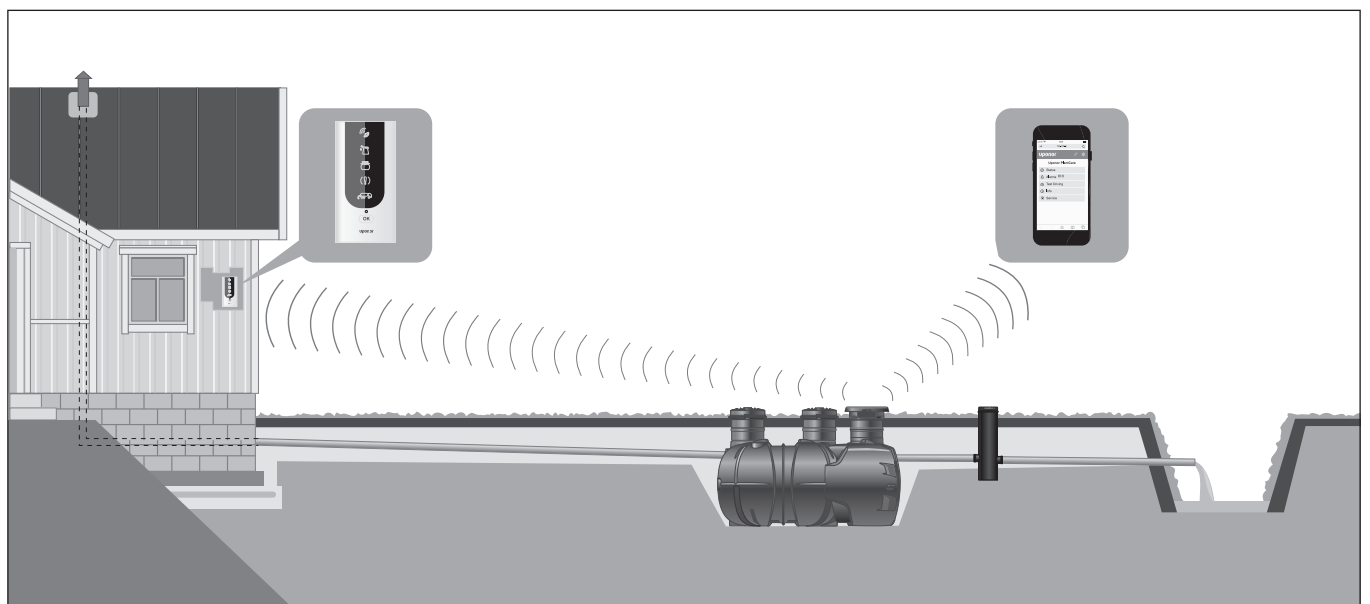

# 1. Overview

The biochemical Uponor wastewater treatment plant is a domestic wastewater treatment system intended for continuous household use, or for a second home equipped for year-round, regular use. The Uponor treatment plant processes all wastewater in a household (from bathing, dishes, laundry, and toilet flushing). It is suitable for all kinds of building lots, including those that are small or rocky.

Foreign objects and materials must not be washed down into the treatment plant, such as debris for solid waste disposal or materials that are classified as problem waste, which can endanger the biological processing of the treatment plant.

## Operating principle

The Uponor Clean II wastewater treatment plant represents top technology in wastewater treatment. Because of its new design, the treatment plant has compact outer dimensions. After installation of the treatment plant, only three unobtrusive covers are visible in the yard.

The treatment plant is primarily designed for use by two households. With a holiday automation technology, it is also suitable for summer cottages that are used frequently year-round. Thanks to the holiday automation, the treatment plant can withstand breaks, as the active sludge is sustained by continued aeration and recycling. The treatment plant is installed in the ground and the extension pipes can easily be extended.

The treatment plant is a biochemical wastewater system, where all household sewage can be directed. The cleaning process works on a batch principle, with an active sludge process and a chemical flocculation. The wastewater is treated in equal batches, so that each batch is purified to the same extent. Microbes living in the active sludge complete a biological purification, while the phosphorus compounds are removed from the wastewater by chemical precipitation. At the end of the cleaning process, the purified water is pumped out, for example, into an open ditch, drainage well or ditch that serves as a discharge point.

## Cleaning process cycle:

- pre-settling of wastewater, storage of incoming water and storage of the sludge in the septic tank
- filling of the process tank
- aeration
- dosage and mixing of the flocculation chemical
- first settling
- excess sludge is returned to the septic tank
- second settling
- discharge of the purified water

If no water is entering the plant, the process is in a waiting or holiday cycle, in which the wastewater is regularly aerated in the process tank. The aeration keeps the microbes active in the process tank.

The Finnish Environment Institute SYKE has carried out the testing according to EN 12566-3 on the Uponor wastewater treatment plant. The tests results are good and meet the purification requirements for emissions to normal and sensitive areas.

The treatment plant is easy to use. The Clean flocculation chemical is added into the plant a few times a year, and the sludge emptying truck comes to empty the sludge accumulated in the septic tank at least once a year. Electric consumption is low primarily because of the mammoth pumping technique. The wastewater and sludge are transferred without mechanical pumping. The air used in the process is produced by blowers located underneath the second cover of the control panel.

The treatment plant has a wireless alarm system, visible through an Info panel installed inside the house. An indicator light on the Info panel indicates when it is time to fill the chemical vessel, if the water level in the tank is too high, if there is a technical malfunction or when the septic tank must be emptied. A test button can be used to query the state of the plant activity. The activity can also be controlled and followed with a mobile device using a PlantCare mobile bookmark.

**NOTE!** PlantCare program uses treatment plants local network and local web browser. It is not connected to internet.

## 2. Planning of Clean treatment plants

Take in consideration in the planning and placing of Clean treatment plants:

### General

- Uponor biological-chemical treatment plants are aimed for the treatment of domestic wastewater in permanent living and free-time houses, which are in regular year-around use.
- Uponor treatment plant treats all domestic wastewater (bath, dish, washing and toilet water)
- Clean treatment plants suit in various kinds of sites, also to small plots and rocky terrains.
- Take into consideration the local orders and guidelines.
- Make sure that the planned incoming wastewater flow does not exceed the max capacity of the treatment plant.
- In case the treatment plant is taken in use remarkably later after the installation, it is recommended to storage the switch cabinet in warm indoors.

### Do not lead these waters to the treatment plant

- Rain and storm waters or foundation drainage waters.
- Potable water filter flushing water
- Emptying water from jacuzzi or hot tub
- Water from garage floor gully

### Placing of Clean treatment plant

- It is recommended to place the plant so that the waters can be led to and from the plant as gravity flow
- Place the plant in a location where it can be installed as close to soil surface as possible.
- In case the in-coming sewer is deep, plan to use Clean pump chamber, so that the plant can be installed in standard depth.
- In case the treated water can not be led with gravity flow to the discharge point, install Uponor pump chamber after the plant.
- Do not place the plant in traffic area.
- For wireless connection between the distance between the Info panel, which is placed in the house, and the plant can be max 60m in unhindered terrain.
- Take the topography into consideration

### Safety distances, according to local guidelines (see the drawing)

#### From the plant to:

- property border 5m (1)
- buildings 5m (2)
- road 5m (3)

#### From the discharge point to:

- groundwater area according to local guidelines (4)
- watercourse 20m (5)
- own or neighbour's potable water well 30m (6), survey from the distance of 150m

**NOTE!** The protective distances in the picture are indicative. Local conditions can affect the protective distances. Contact local environmental office.

### Trench

- Take in consideration local climate and frost susceptibility. If needed, isolate on top of the plant and pipes
- If the distance between the house and the plant exceeds 25m, install a rodding-t in the sewer line
- The highest allowed groundwater level is 1m from above the bottom of the tank.
- Drain the trench, to avoid groundwater pressure to the tank in dense soil.
- Anchor the tank, if the groundwater is high
- Shape the soil surface so that the surface waters are guided away from the tank

### Discharge point

- Select suitable placement and method for discharging the treated water
- Make sure that the discharge point can receive the entire treated batch
- Plan the discharge point so that no back-flow occurs

### Ventilation

- The ventilation of sewer line shall take place above the highest point of the roof of the house and as far as possible from the replacement air inlet of the house. Note. do not use a vacuum valve.
- In case there is a pump chamber before or after the plant, the ventilation needs to be arranged on a different way.
- Make sure the replacement air has free entrance in the discharge point

### Sludge emptying

- Make sure that the property road can handle the weight of the sludge truck
- Make sure that the distance from the road allows sludge emptying. Note. the safety distance from the plant to the road needs to be min. 5m

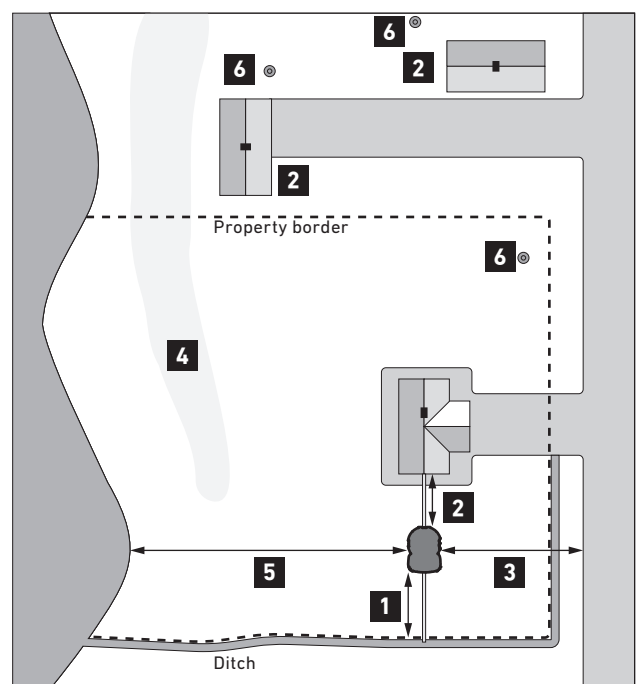

Safety distances

# 3. Installation and dimensional drawings

Clean II (Uponor code 1133828) + Uponor Sample Chamber 315 (uponor code 1003559).  
 Two family houses (4-10 persons), domestic wastewater

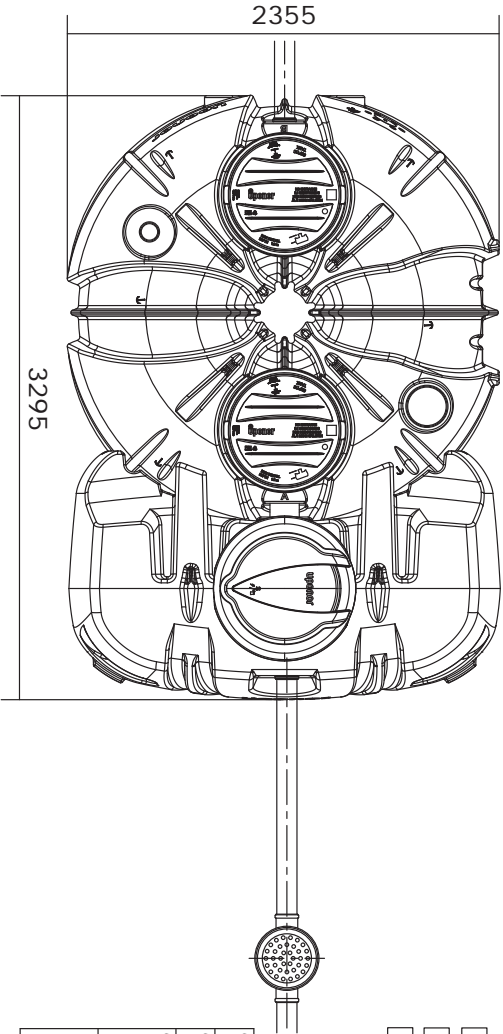
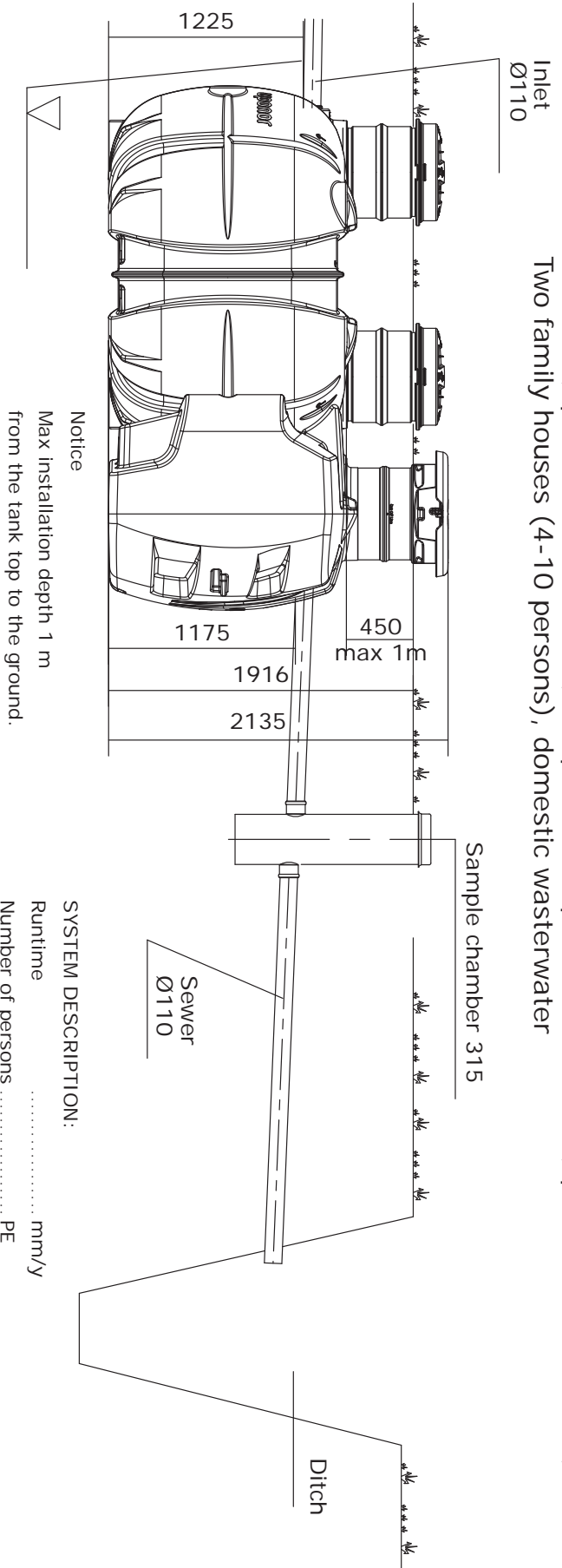

**SYSTEM DESCRIPTION:**  
 Runtime ..... mm/y  
 Number of persons ..... PE  
 Dim. water volym ..... ml/d (max 2100 l/d)







- Accessories:**
- Frost insulation
  - Anchoring
  - Extension pipes Ø 560 with sealing ring
- Outlet:**
- Ditch
  - Soil treatment..... m<sup>2</sup>
  - Infiltration chamber

We reserve the right to changes.



City/Village	Block/Yard	Lot/Rno.	Notes from administrative authority	Drawing type	Number
Construction act					
Construction site: name and address				Qualifies	Scale
Designer: name, date and signature				Planning, work no. and drawing no.	Modification

## 4. Technical information

Uponor Clean II treatment plant			Monitoring functions
<b>Product information</b>			<p><b>Display panel indicators</b></p>  <p><b>Connection to the treatment plant</b></p>  <p><b>Chemical running out</b> Fill the chemical vessel (20 l)</p>  <p><b>High water level</b></p>  <p><b>Possible hardware malfunction</b> Call a service technician</p>  <p><b>Septic tank full</b> Order a sludge emptying truck</p>  <p><b>OK indicator light</b> Everything in working order</p>
Uponor number	1133828		
LVI number	3624861		
EAN code	6414900301565		
<b>Measurements</b>			
Width, mm	2355		
Length, mm	3295		
Inlet connection height, mm	1225		
Outlet connection height, mm	1175		
Height with extension pipe, mm	2135		
Transport height, mm	2135		
Weight, kg	450		
Fitting size, mm	110		
Septic tank volume, m <sup>3</sup>	4,6		
Process tank volume, m <sup>3</sup>	2,2		
Total volume, m <sup>3</sup>	6,8		
<b>Electricity</b>			
Electric connection	230V 1~ phase, 10A fuse		
<b>Flow data</b>			
Standard flow, l/day	1500		
Maximum flow, l/day	2100		
Batch size, l	350		
Pump-out time, min	16		
Occupancy	3–10		
<b>Operating costs</b>			
Chemical consumption per year, l	60–120		
Chemical consumption/batch, dl	1,0		
Electricity consumption per day, kWh	1,6		
Electricity consumption per year, kWh	584		
Sludge removal	At least once a year		
<b>Installation conditions</b>			
Installation depth from inlet sewer to the ground, max.	1,2 m		
Installation depth on top of the tank, max.	1,0 m		
Extension pipe Ø	560 mm		
<b>Accessories</b>			
	Uponor number	LVI number	
Uponor anchoring system	1003563	3625391	4 pcs
Uponor settling chemical (aluminium chloride)	1003575	3624997	15 l
Clean extension pipe 560 x 1 m	1057363	3625015	3 pcs, with installation depth > 0,7 m
Extension pipe seal 560	1003600	2521817	6 pcs
Sampling well	1003559	3625090	

# 5. Installation

## Trench

When measuring the length and width of the trench, allow for a workspace of at least half a metre around the tank. In normal installations, the depth of the trench for treatment plants is approximately 2 metres. For deeper installation, see the text for “Extending riser pipes”.

If the treatment plant is installed in dense soil or in an area with high groundwater levels, the treatment plant must be anchored. Allow for a space of at least 60cm measured from the outermost edge of the treatment plant. Make sure that the trench has underground drainage, so that any water that accumulates there does not put a strain on the tank. This also helps to anchor the tank. Install a cable protection pipe between of the treatment plant and the building’s main distribution board, in which the electrical cable can be installed. Mark according to requirements.

Remember that the distance between the plant control centre and the Info panel inside the house must not be more than 60 metres, but it is advisable to install the display panel as close as possible to the treatment plant. Do not place the display panel in a location where buildings or other obstacles can block the wireless connection.

During the installation, it is recommended to fill the septic and process tank with water. The filled tank stabilises the

plant and prevents it from rising in the trench if water is accumulated there.

## Anchoring

The treatment plant must be anchored if it is installed in dense soil, such as clay or silt soil, or if the groundwater level is high. The Uponor anchoring system can be used to anchor the treatment plant (see Uponor anchoring system installation instructions). In a trench dug into clay or cliffy surface, provide drainage to prevent any surface water that enters the trench from collecting and subjecting the tank to pressure.

### Contents of the package:

The treatment plant is delivered ready for installation. Parts of the treatment plant are described on page 17.

Inside the treatment plant you will also find an accessory box: 2 fittings, 110mm inlet pipe, display panel and power supply, owner’s manual, safety goggles and gloves.

Uponor anchoring system product number 1003563

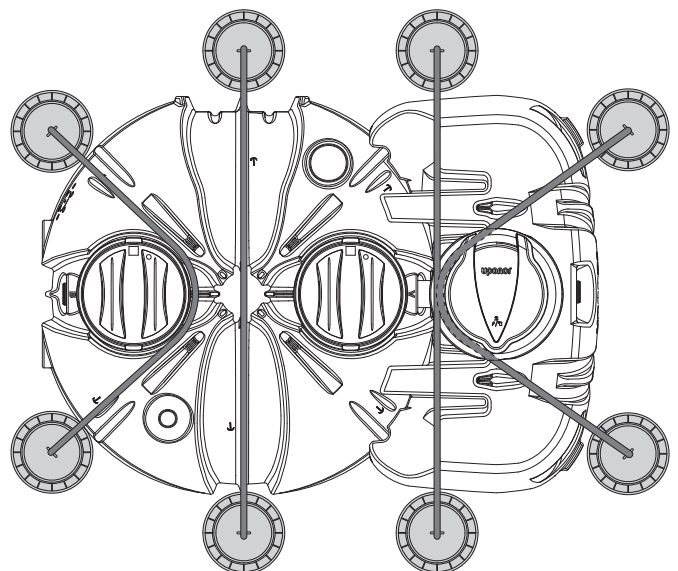

## INSTALLATION

### Trench bottom pre-work

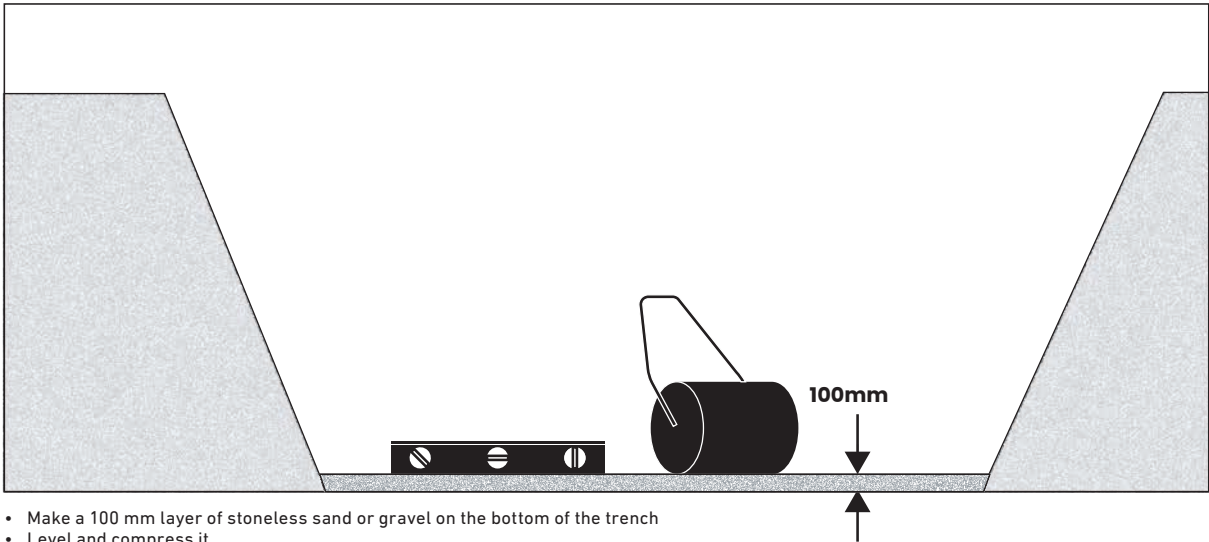

### Lifting, backfilling and anchoring

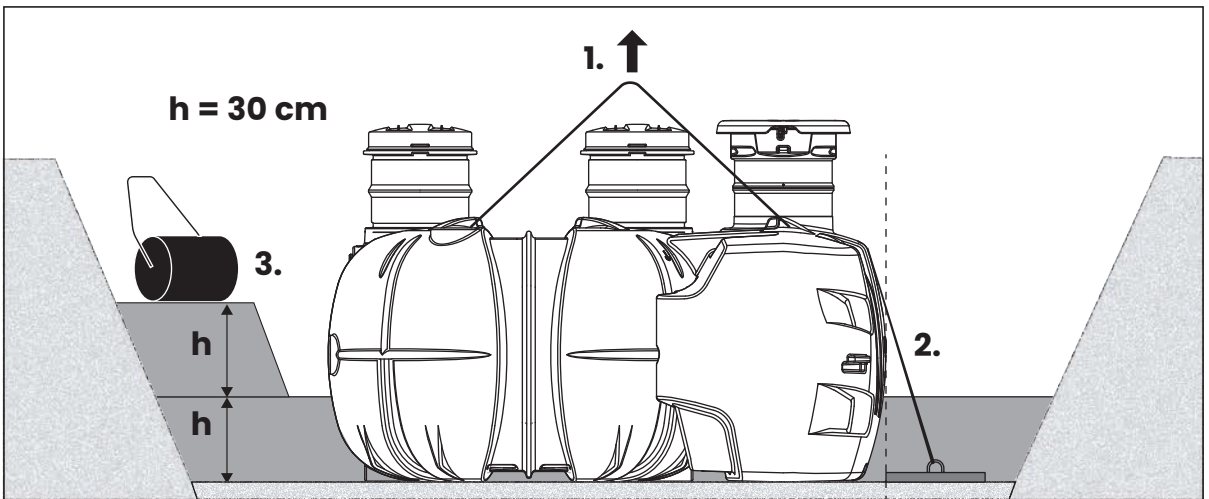

### Connections

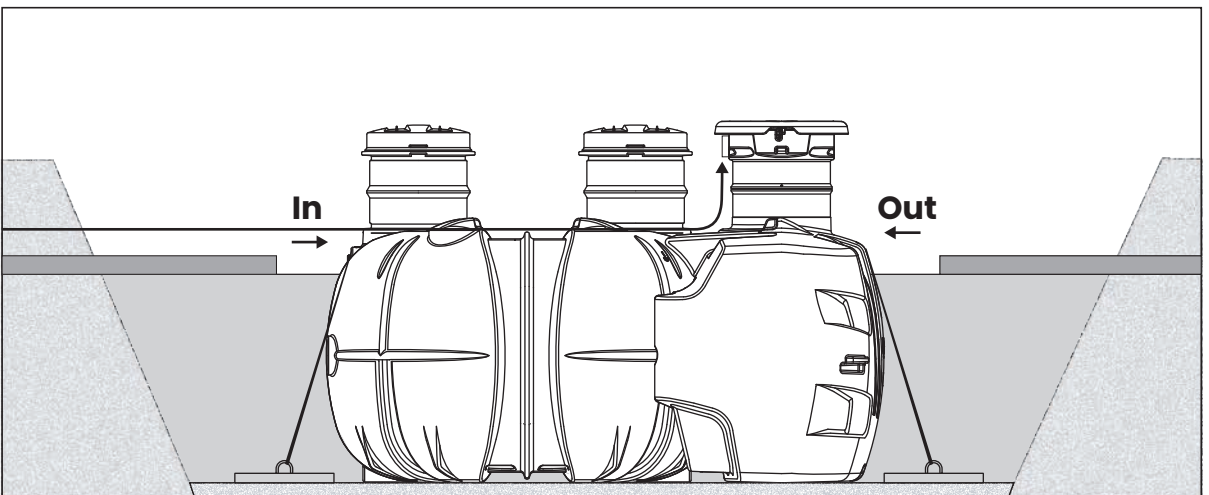

## Final backfilling

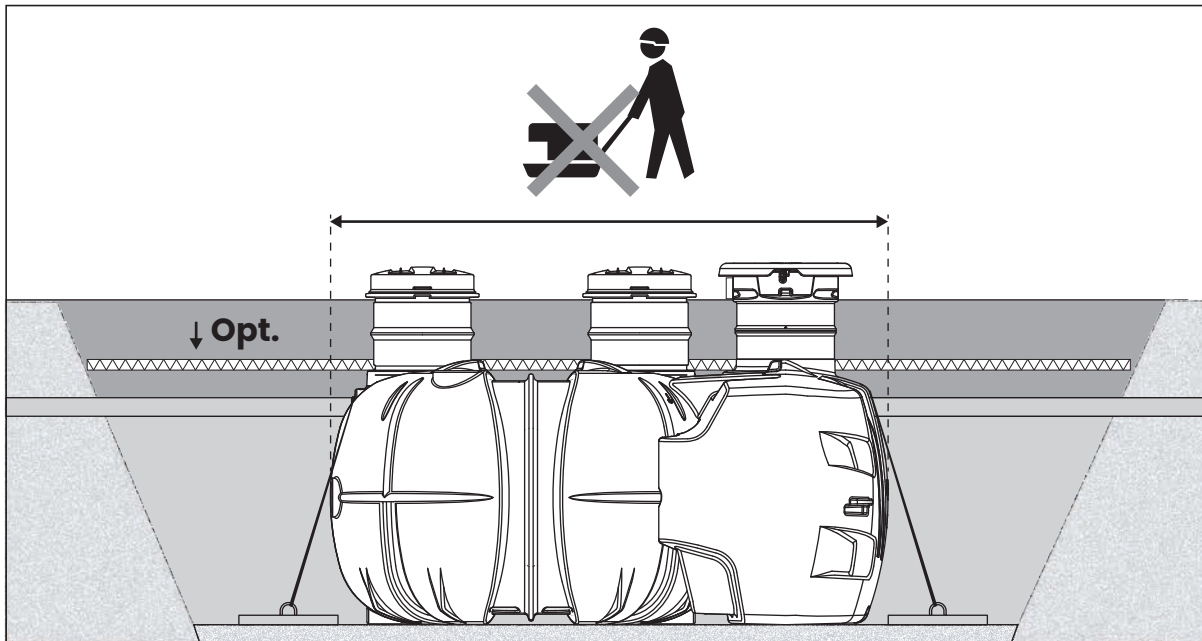

- Backfill the rest of the trench. Do not compress with machine on top of the tank
- Shape the soil surface to guide surface waters away from the tank

If there is reason to assume that the frost penetrates deep into the ground, protect the tanks and other areas prone to freezing with a thermal insulation board (e.g., with a 100 mm thick foam). In the winter, the snow covering the treatment plant and sewer line should not be removed, except for maintenance work. Fill the

trench. Shape the ground so that the surface water is directed away from the tank. Leave a space of about 10 cm between the cover and the ground to ensure the operation of the wireless alarm and the supply of air inside the control centre.

## EXTENDING RISER PIPES

### 1. Emptying and cutting the risers

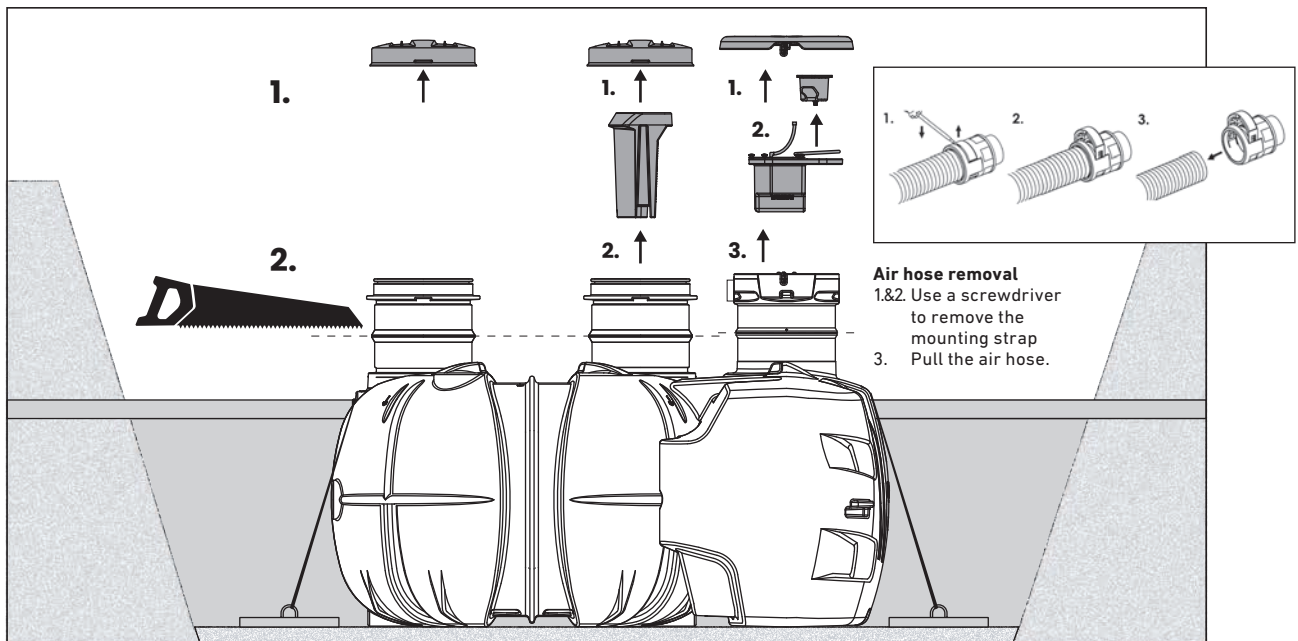

- Remove the lids
- Disconnect the air-intake hoses from the of the switch cabinet and compressor unit (PIC 1)
- Lift switch cabinet and compressor unit and disconnect the air hoses from their underside and lift them out (PIC 2)
- Lift up the coloured air hoses with protective tubes.
- Disconnect the air hoses from the chemical vessel and lift the vessel out (PIC 3)
- Cut the neck of the shaft with a saw along its middle, marked "offline"

## 2. Installation of extension pipes

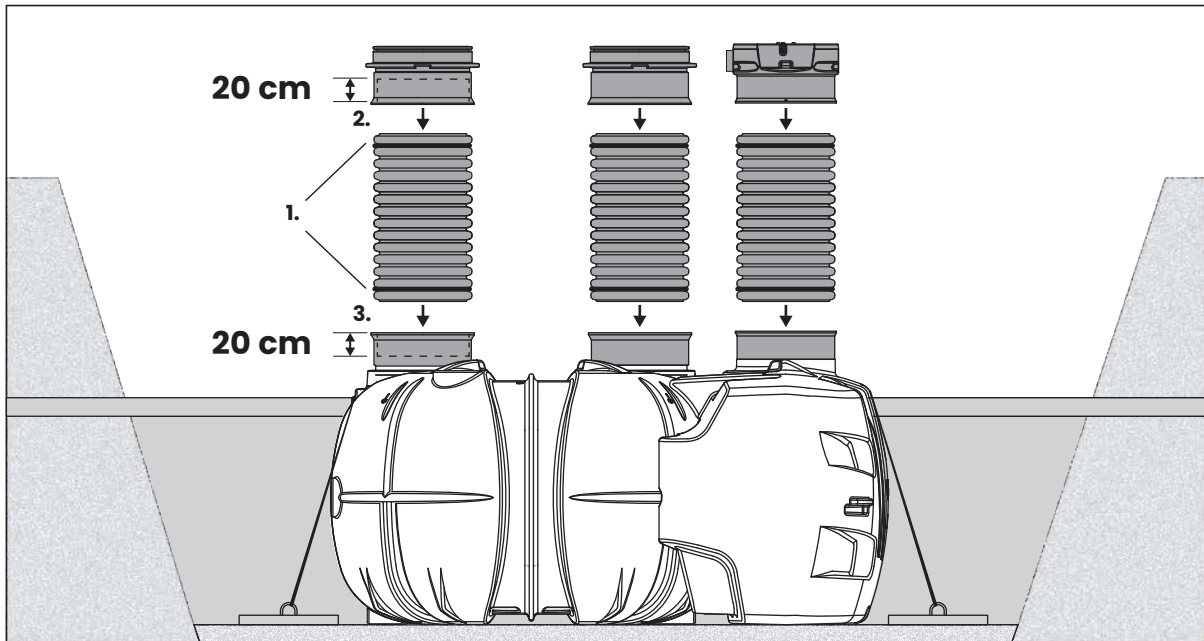

- Place a rubber-sealing ring around each end of the pipe. Lubricate the sealing ring.
- Push one end of the extension pipes into the sawn risers. Push them all the way to the bottom of the sockets
- Push the top part of the riser on the other end of the extension pipe. Push them to the bottom of sockets.

## 3. Mounting chemical vessel, switch cabinet and lids

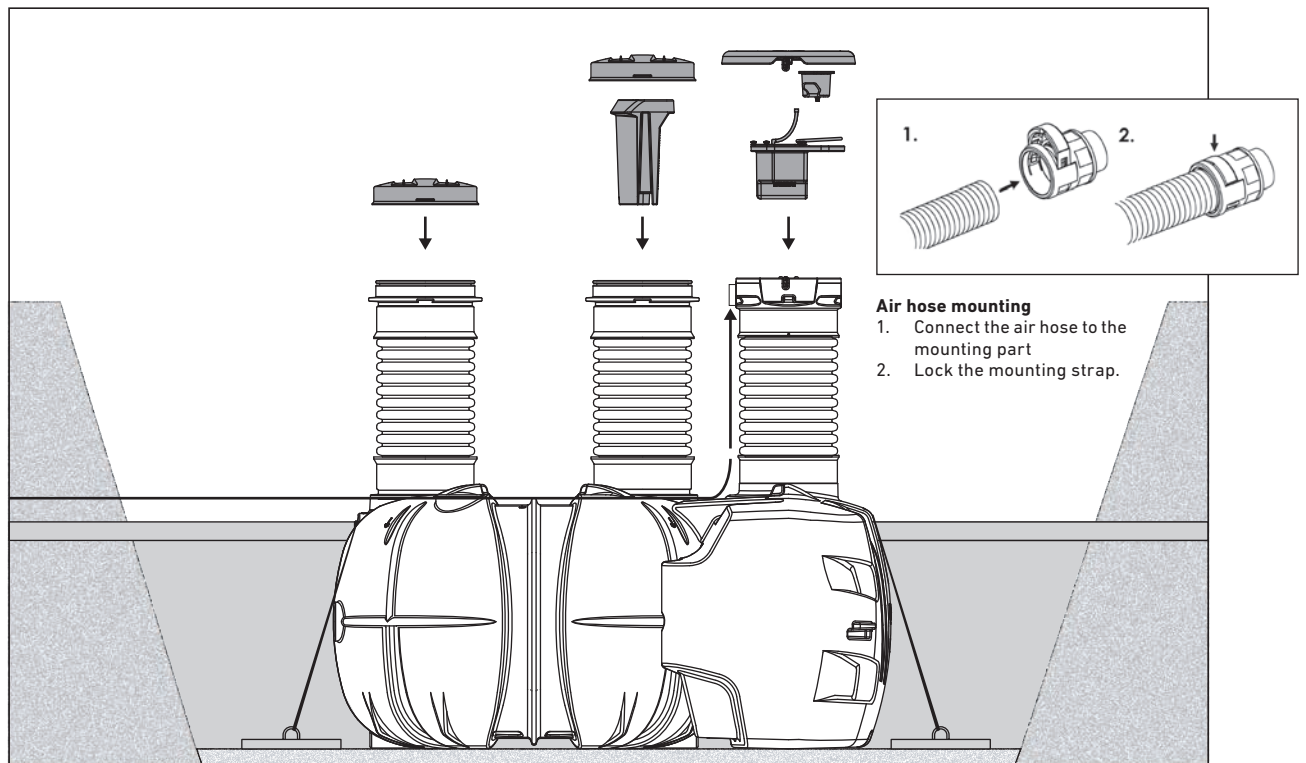

- Connect the air hoses to the chemical vessel and lift the vessel in A
- Connect the air hoses to the bottom of the switch cabinet and compressor unit, and lift them to the riser
- Connect the air-intake hoses to the switch cabinet B and compressor unit C
- Connect the lids

#### 4. Final backfilling

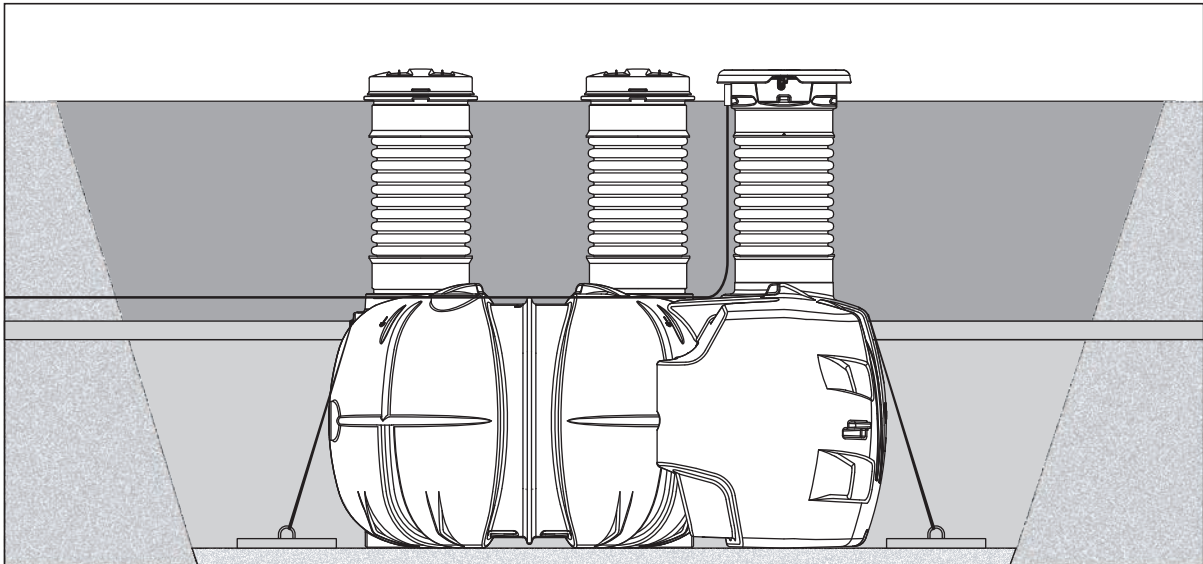

- Backfill the rest of the trench. Do not use compress with machine on top of the tank
- Shape the soil surface to guide surface waters away from the tank

#### Connecting the supply cable

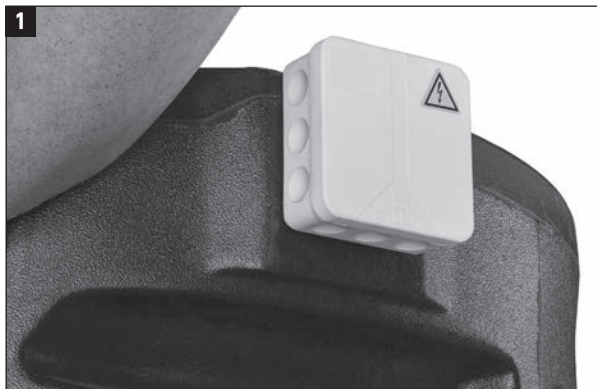

Have an electrician to connect the power cable to the connection box. The cable must have a residual current circuit breaker. Overvoltage protection is recommended in lightning-sensitive areas.

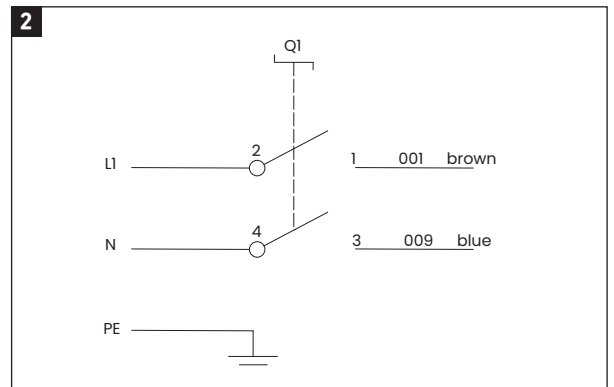

Supply 230 V AC 50 Hz, max. fuse 10 A



Fill the chemical vessel with the Clean Flocculent (30 litres). Wear protective gloves and goggles when handling the chemical. For detailed information on the flocculation chemical, see the enclosed safety data sheet or our website [www.uponor.com/fi-fi](http://www.uponor.com/fi-fi), [www.uponor.com/sv-se](http://www.uponor.com/sv-se).

The treatment plant is ready for use.

## 6. Setting up the wireless alarm system

To ensure a correct cleaning result and trouble-free operation, a few more steps must be taken before starting the treatment plant.

### Info panel placing

Mount the Info panel in a planned nearby location inside the house. Remember that the distance between the control centre and the Info panel should not exceed 60 metres. However, it is advisable to install the display panel as close as possible to the treatment plant.

Do not place the display panel where buildings or similar obstacles can block the wireless connection.

### Setting up the wireless connection

#### Pairing

**NOTE!** The following steps must be performed without interruption for successful deployment.



Turn on the control centre by plugging the power cable. so that the Info panel is not turned on. The control unit will then start pairing to search for the display panel for up to 5 minutes to establish a wireless connection ("P ---" will appear on the control unit display).



Connect the AC adapter to the wall and the Info panel. Pairing can be activated during the first 5 min. Start pairing by pressing and holding the OK button for at least 5 seconds.



After 5 seconds, the signal light of the wireless connection starts blinking and the connection is established. This takes 5–10 seconds, after which the signal light turns off and the green OK light turns on.

**NOTE!** If no connection is established, the wireless connection light turns red. In this case, reconnect the wireless connection as described above. If the wireless connection fails after several attempts, try relocating the display panel. Make sure that the distance between the control centre and the display panel is not too long and that buildings, for example, do not obstruct the radio signal.

#### Info panel reset

If the connection is not established after two or three attempts, try to reset the info panel by erasing the existing pairing. Connect power the Info panel. Pairing can be erased during the first 5 min by pressing and holding the OK bottom for 10 seconds. All red LEDs blink a few times to indicate that pairing is erased. Info panel is now ready to be paired again according pictures 1, 2, 3.

#### Turning on/off pairing function

In case there is no Info panel connected to the treatment plant, the pairing function shall be turned off. This needs to be done to avoid "Wireless connection" alarm (E011).

Turn off the pairing function by pressing and holding the test button for 5 seconds during pairing mode. A successful turning off is visualized by displaying 'Poff' (= pairing off).

Pairing function can be turned back on by pressing and holding the test button while connecting the power to the control unit. Pairing is started and it is visualized by displaying normal pairing 'P---'.

## Range test

With the help of the radio connection range test, it is possible to find a suitable location for the display panel inside the property. The range test starts automatically after a successful pairing of Control Unit and Info Panel.

1. The range test can be used to verify that the radio reception is good at the display panel installation site. During the test, three colours of LEDs may flash on the display panel:
  - Green = good connection
  - Yellow = connection moderate
  - Red = poor connection or no connection at all
2. The range test ends automatically after 15 minutes. The test can also be interrupted by pressing the OK button on the display panel or the test button on the control centre.

If you want to make a new range test, you have to un-pair the Info panel first. It can be done during 10 min after power-on by pressing and holding the OK button for 10 sec. A new range test can be started by following the steps in **Setting up the wireless connection**.

4



Lock the treatment plant cover. The sewage treatment system is ready for use.

## 7. PlantCare

The treatment plant activity can be followed with a mobile phone or other mobile device using a PlantCare mobile bookmark. In order to connect the mobile device to the treatment plant you have to be close to the plant, within the range of Wi-Fi net.

**NOTE!** PlantCare program uses treatment plants local network and local web browser. It is not connected to internet.

### Connecting to PlantCare

#### 1. Connect to Wi-Fi

Go near the treatment plant. Search with your mobile device the Wi-Fi of the plant. Select the Wi-Fi which starts with UPONOR.

Wi-Fi password is the network last part of the WLAN id in reverse. E.g., If the ID of the network is UPONOR\_WWT\_AC617111 –network, the password is 111716CA.

If there are problems in joining, close all browser pages.

#### 2. Open PlantCare

Open the browser and select address [uponor.plantcare.net](http://uponor.plantcare.net)

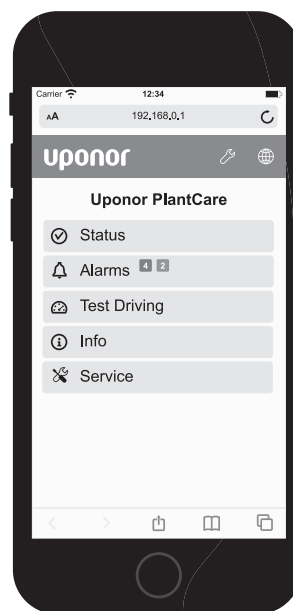

# 8. Operation

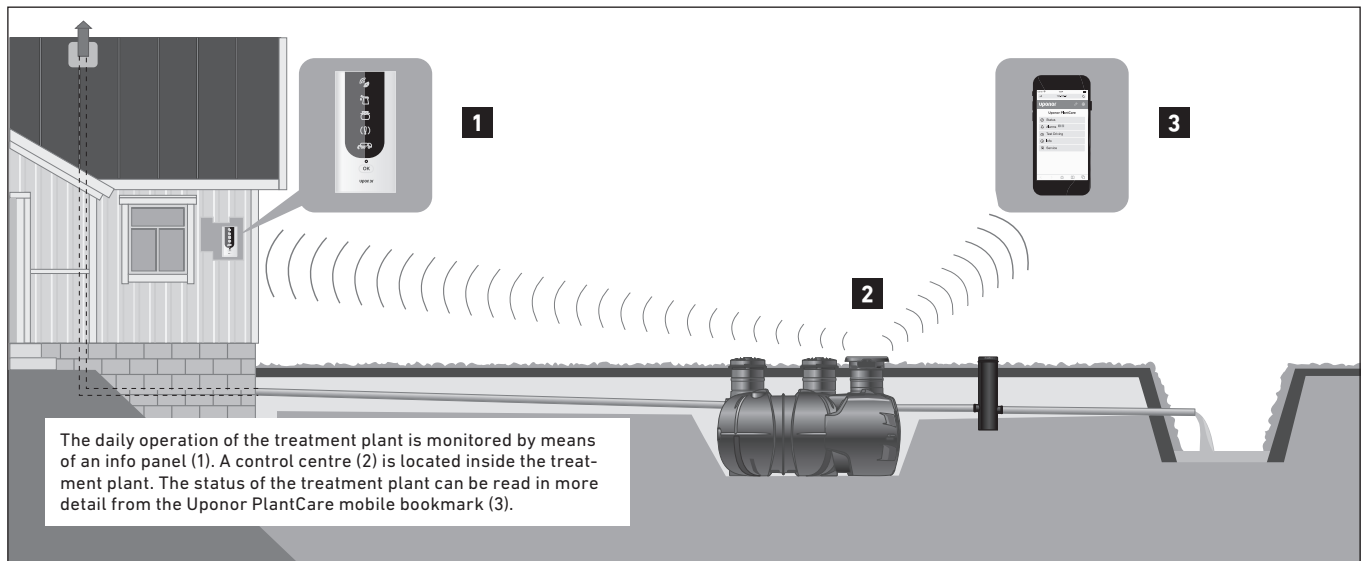

## Info panel

The Info panel and the treatment plant control centre are connected wirelessly. The range of the wireless connection is 60 metres.

The Info panel has the following functions:

- Four alarm symbols
- Green OK light
- One reminder symbol
- OK/reset button

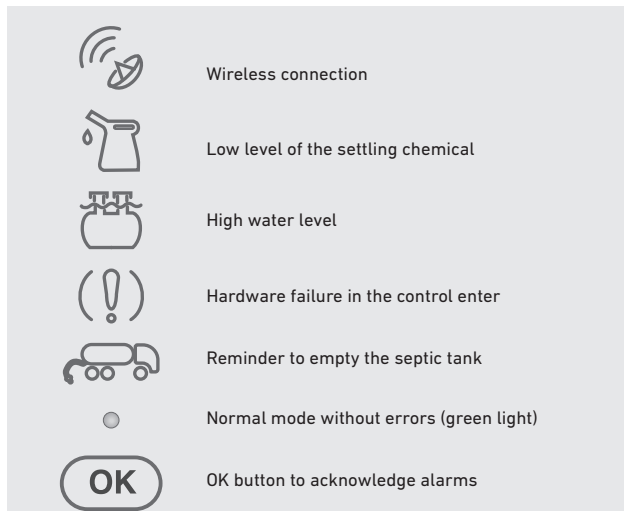

Info panel indicators.



1 Screw the Info panel wall bracket to a wall inside the property.



2 Plug the Info panel into an electrical outlet through the included AC adapter and mount it in a wall mount.



3 To detach the Info panel from the wall bracket, press on the top, for instance, with a screwdriver tip.

## The alarm function of the info panel

The display panel has four alarm functions that are activated in the event of a fault. With an activated alarm, the info panel works as follows:

1. The green OK light turns off.
2. The red fault indicator light will start flashing and the alarm will sound (the beeper will sound for 30 seconds per hour).
3. Press the OK button to acknowledge the alarm. The alarm light stops blinking and stays on. The signal beeping goes off.
4. When the fault has been rectified, the indicator light goes out and the green OK light comes on.

### The reminder function of the Info panel

Clean II has two kinds of reminder functions; service reminders and a sludge emptying reminder.

The Info panel indicates when it is time to make periodical service (1-year, 3-year or 6-year-service) and when it is time to empty the septic tank of the sludge. It is recommended to make service within 3 months of the reminder. Sludge emptying must be completed within one month of the reminder.

### Sludge emptying reminder works as follows:

1. The yellow sludge truck light will start to flash and the alarm signal will sound (the beeper will sound for 30 seconds per hour). The green OK light is on.
2. To clear the sludge emptying reminder, press the OK button, at which point the reminder light will stop flashing and remain on. The alarm sound goes off.
3. When the septic has been emptied, reset the reminder function by pressing the test button on the control centre. Press the test button for more than 10 seconds, and E000 is displayed on the control panel. The sludge truck light on the display panel goes off. The reminder can also be acknowledged using PlantCare.



### Service reminder works as follows:

1. The exclamation mark light starts to flash in yellow and the alarm signal will sound (the beeper will sound for 30 seconds per hour). Same time on the control unit display appears the error code E401, E402 or E403 depending on the reminder type.
2. To acknowledge the service reminder, press the OK button, at which point the reminder light will stop flashing and remain on. The alarm sound goes off.
3. After the service has been carried out, reset the reminder function by pressing the test button on the control centre when there is the error code of the reminder on the display. Press the test button for more than 5 seconds, and the error code flashes on the display and then disappears. The exclamation mark light on the Info panel goes off. The reminder can also be acknowledged using PlantCare.

### Info panel settings

There are three switches on the back of the info panel that can be used to set the following functions:

#### Switch 1. Alarm on/off

The upper toggle switch is used to select whether the signal sound is on or off in the event of an alarm.

#### Switch 2.

Not in use with Clean II.

#### Switch 3. Sludge emptying reminder

The lower dip switch is used to activate or deactivate the sludge emptying reminder. If the treatment plant is covered by regular municipal septic emptying, for example, the reminder function can be switched off.

## Control unit

The control unit is in the treatment plant under the cover of the process tank. The control unit has a display from which the batch counter value can be read, the status of the treatment plant can be checked and a possible error code can be read. Outside the control centre, there is a test button that can be used to activate the treatment plant status display, start a test program and reset the sludge emptying reminder

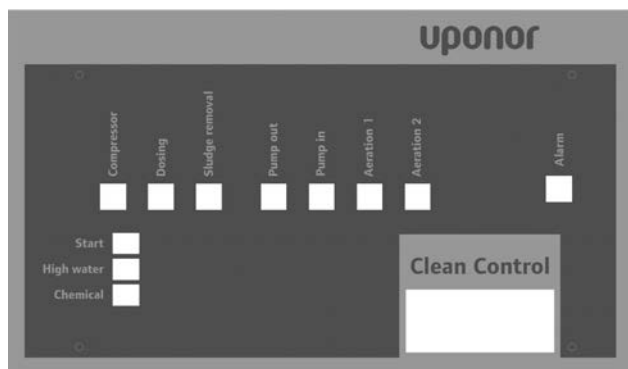

## Normal operation

In a normal situation, the display shows the batch counter value.

## Malfunction

The display alternates between the batch counter value and the error code. See page 21 for operation during a malfunction. If several faults are active at the same time, their error codes are displayed in sequence.

## Treatment plant status

The display shows the stage of the cleaning cycle in the treatment plant. The status display is initiated by briefly pressing the test button (for less than 5 seconds). The display shows S and a series of numbers. The code indicating the status of the treatment plant is displayed for 30 seconds, after which the display returns to the batch counter value.

## Test cycle

The treatment plant has a test cycle that can be used to check the operation of the various units in the treatment plant. In order to see in the tank before starting the test cycle, lift up switch cabinet and compressor unit out of their place. Be careful not to kink the air hoses below them.

See where each unit is located in the process tank. The test cycle is started by pressing the test button for longer than 5 seconds but less than 10 seconds. When the test button is fully pressed, the display will show the seconds: \_\_ \_1, \_\_ \_2, \_\_ \_3, \_\_ \_4, S \_\_5, S \_\_6, S \_\_7 etc. The test button is released when the display has reached a reading of S \_\_5.

When the test cycle has started, the display will show S400. The treatment plant then performs all pumping operations in sequence.

Function	Time	Display
1. Pump in	20s	S401
2. Sludge removal	20s	S402
3. Pump out	5s	S403
4. Chemical filling	90s	S404
5. Chemical dosing	10s	S405
6. Sedimentation (None of the components are on).	10s	S406
7. Aeration I	30s	S407
8. Aeration II	30s	S408

After the test period, the display returns to show the batch counter value. The cleaning process returns to normal.

# 9. Operating principles

## Treatment plant parts

The treatment plant main parts:

1. Septic tank
2. Process tank
3. Control centre and compressor II
4. Chemical vessel and dosing pump



### 1. Septic tank

The solids are separated by settling in a septic tank. Sludge accumulates in the septic tank and is removed by a sludge emptying truck. The treatment plant has an emptying reminder that indicates the need for emptying. The sludge is only emptied from the septic tank. Do not empty the process tank.

### 2. Process tank

The volume of the process tank is 2.2m<sup>3</sup>. All functional units for different uses are located in the tank. Each unit is connected to the control centre with air hoses of different colours.

### 3. Control centre

The main components of the control centre are:

5. Control unit
6. Test button
7. Valve package
8. Two compressors (other is located in a separate compressor unit)
9. Measurement unit of the water level

#### Control unit

The control unit controls the operation of the treatment plant. The cleaning process starts over from the beginning if it is started after stopping. The same thing happens after a power failure. The control unit has a display from which the status of the treatment plant and the error codes can be seen.

#### Compressors

Clean II has two 50-watt compressors. One provides pressure air for the various functions. Both compressors are used during aeration.

#### Starting level

The cleaning process starts when the water level in the process tank has risen to the starting level.

#### Alarm level

An overfill alarm is sent to the display panel if the water level in the septic tank rises to the alarm level or if the water level in the process tank does not drop during emptying.

### 4. Flocculation chemical storage vessel and dosing pump

There is a chemical storage vessel in the riser pipe of the settling tank. The vessel must be filled regularly. The filling cycle depends on the amount of wastewater entering the treatment plant.

The dosing pump is located on the bottom of the chemical vessel. The amount of one chemical dose is approximately 0.8dl/batch. On delivery, the dosing pump is set to this value. The Clean Flocculation chemical, an aluminium chloride solution, is the only approved chemical.

Before use, read the safety data sheet for the chemical. The flocculation chemical is an irritant, so it must be handled with protective gloves. If the chemical splashes on the skin, it should be rinsed off with clean water.

For more information on the Clean Flocculation chemical, see the safety data sheet. The data sheet is delivered with the treatment plant, and you can also find it on our website

[www.uponor.com](http://www.uponor.com)

## Functional units

More information on page 23.

### 1. Filling unit

With the air lead into the filling unit, the clarified wastewater is pumped from the septic tank into the process tank. The air hose of the filling unit is blue.

### 2. Aeration unit

The function of the aeration unit is to aerate the wastewater and mix the wastewater to provide good contact with microbes and the wastewater. The microbes necessary for the biodegradation of organic matter needs oxygen. Aeration unit is also used to mix the chemical. The addition of a flocculation chemical to the system guarantees a high treatment result and the precipitation of phosphorus from the wastewater. The color of the air hoses of the aeration units is grey.

### 3. Chemical dosage

The flocculation chemical dosing pump is located in the chemical storage vessel, which is in the riser pipe of the septic tank. The chemical is dosed into the treatment plant using compressed air. The air hose of the chemical dosing pump is yellow and the dosing hose is grey.

### 4. Sludge removal unit

After the first settling, the excess active sludge is pumped into the septic tank. The air hose of the sludge removal unit is brown.

### 5. Emptying unit

After the second settling, the purified water is pumped out of the treatment plant. The air hose of the pump-out unit is red.

### 6. Start level unit

The starting level is the level that the water in the process tank has to reach for the cleaning process to start. The air hose of the start level unit is green.

### 7. Alarm level unit

The alarm level unit gives an alarm if the water level in the septic tank exceeds the maximum level. The air hose of the alarm level unit is black.

## Operation of the cleaning process

The wastewater is pre-treated in the septic tank, where solids that are heavier and lighter than water are separated from the wastewater. The solids are stored in the septic tank.

The biochemical treatment of the wastewater takes place in the process tank.

### Steps in the cleaning process

#### 1. Filling of the process tank

The process tank is filled by pumping the pre-treated wastewater from the septic tank until the start level in the process tank is reached and the cleaning cycle starts.

#### 2. Aeration

Aeration keeps the active sludge in motion and ensures that the oxygen needed for microbial activity is available.

#### 3. Dosage and mixing of the chemical

The flocculation chemical is used to remove phosphorus from the wastewater. The flocculation chemical is mixed with the wastewater by a short aeration.

#### 4. Flocculation, sludge removal and settling

The solids are allowed to settle for about an hour. During settling, the flow of water in the process tank is stopped and the sludge settles to the bottom. The excess sludge is pumped into the septic tank between settling cycles. The level of active sludge in the process tank is kept constant, for it ensures the efficient operation of the biological process.

#### 5. Removal of purified water

After settling, the purified water is pumped out of the treatment plant.

#### 6. Waiting and holiday cycle

If the start level in the process tank is not reached during pumping, the treatment plant enters the waiting cycle.

The waiting cycle keeps biological activity alive.

The Uponor Clean II treatment plant has a holiday automation function. If the start level is not reached for three days, the treatment plant will move into the holiday cycle. During the holiday maintenance cycle, the active sludge is kept alive even for a long break (max. 3 months).

When the start limit is reached during the waiting or holiday cycle, a new cleaning cycle will start.



# 10. Maintenance

## Maintenance performed by the property owner

To ensure trouble-free operation, the treatment plant must undergo a few maintenance and inspection measures at regular intervals. Wear protective gloves and follow instructions when performing maintenance. After the procedure, lock the lids of the septic tank and the control centre and wash the hands thoroughly.

## Key maintenance procedures

The need for chemical refilling may vary, in normal use the chemical should be added 2-3 times a year. The consumption of the chemical depends on the amount of wastewater entering the treatment plant.

The septic tank must be emptied after a sludge emptying reminder or at least once a year.

The operation of the treatment plant is monitored from an Info panel inside the house. In addition, the formation of batches from the batch counter, the odour of the process tank and the quality of the exiting water must be monitored.

Activity can be tracked using the PlantCare mobile application.

The chemical vessel tank is located in the septic tank under the second cover. Do not lift the chemical vessel to the ground when filling it with the chemical. The capacity of the chemical vessel is 35 litres. Protective gloves and goggles must be worn when handling the flocculation chemical. Before handling the chemical, read the safety data sheet at the end of the manual at [www.uponor.com](http://www.uponor.com)

Only the Clean Flocculation chemical is used in the treatment plant. When the chemical is depleted, an alarm will appear on the Info panel and on the control centre.

If there is mark of sedimentation of chemical in the vessel, flush the tank and chemical pump with water. Pour the liquid into the septic tank. Always use safety goggles and gloves.

If there is sediment in the canister, don't fill it into the chemical vessel.

The sludge is only emptied from the septic tank under the first cover, the process tank is not emptied. Check the functional units of the process tank for dirt regularly, for example twice a year. If necessary, flush the units with a garden hose.

Record all maintenance operations, such as inspections, chemical vessel fillings, sludge emptying, repairs and alterations, in the logbook.

## Service agreement

It is recommended to sign a service agreement with an Uponor authorized service provider.

**NOTE!** Regular inspections and emptying ensure the operation and longevity of the treatment plant.

## Useful information

Biological purification is particularly sensitive to various toxic substances, such as oils, strong acids and bases. Do not flush into the drain the following:

- household and other waste (potato or fruit peels, food scraps, coffee grounds, cigarette butts)
- wrapping or newsprint, paper towels
- textiles, e.g., tights
- diapers, tampons, cotton swabs, bandages or condoms
- outdated or unused medicines
- sand or construction waste
- grease, oil or substances that form toxic gases
- petrol, solvents, paints or other flammable or explosive substances

## Hardware failure situations

There is no immediate emergency in the event of an error: the water drains from the treatment plant as an overflow and receives at least a septic tank treatment.

If the Info panel gives an alarm, check the following before calling for service:

- Error codes displayed on the control centre or error code reported by the PlantCare monitoring system.
- Water levels in the septic tank and process tank
- Whether water can escape freely from the treatment plant (e.g., the discharge point is not frozen or blocked) and no water is flowing from the discharge point towards the treatment plant.

# 11. Instructions for sludge emptying

Driving over the tank with a sludge truck is not allowed. Sludge emptying must occur min. 5m from the tank side.

The Info panel reminds you to empty the sludge. If necessary, the sludge can be emptied earlier.

Only the septic tank is emptied in the Uponor Clean II treatment plant (see the pictures).

Empty the septic tank completely. After emptying, it is recommended to fill the septic tank with clean water. Finish the work by locking the cover. Record the emptying event and the batch counter value in the logbook. Reset the sludge emptying reminder counter.

## Resetting the sludge emptying reminder

The sludge emptying reminder is reset by holding down the green test button on the control centre for more than 10 seconds. When the button is pressed to the bottom, the display reads the seconds. Release the button after 10 seconds when the display shows E000.

The sludge emptying reminder can also be reset with Plant-Care.

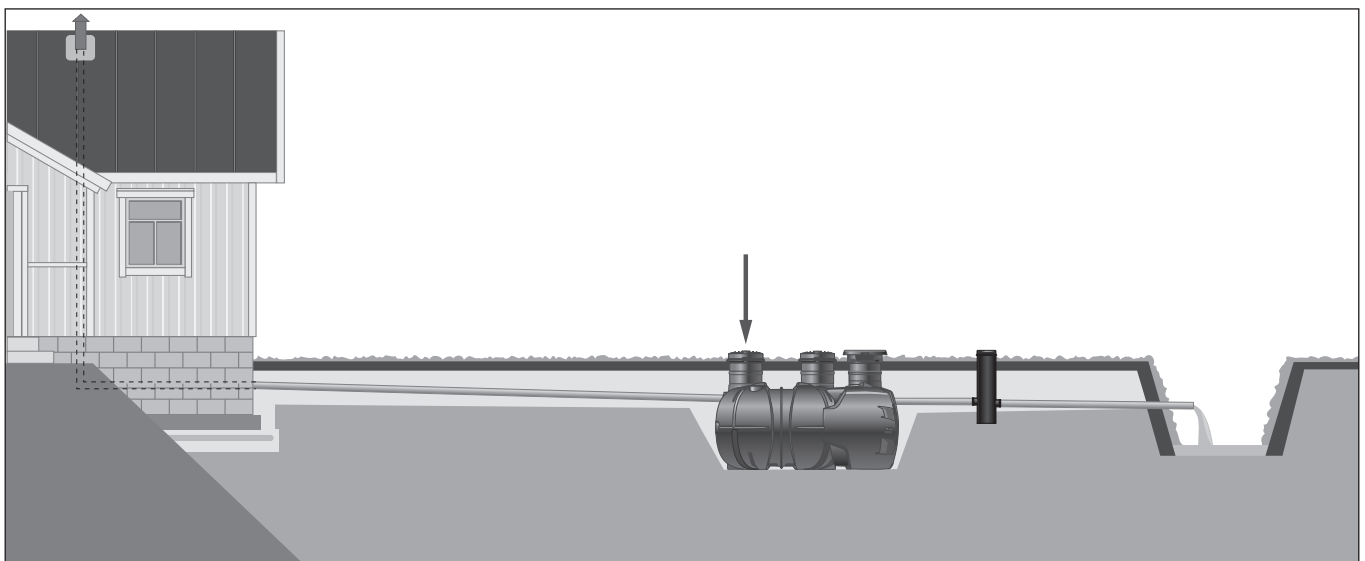
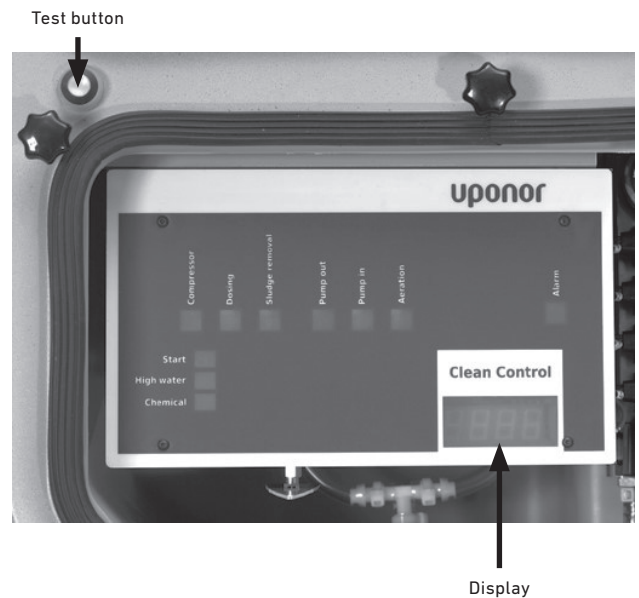
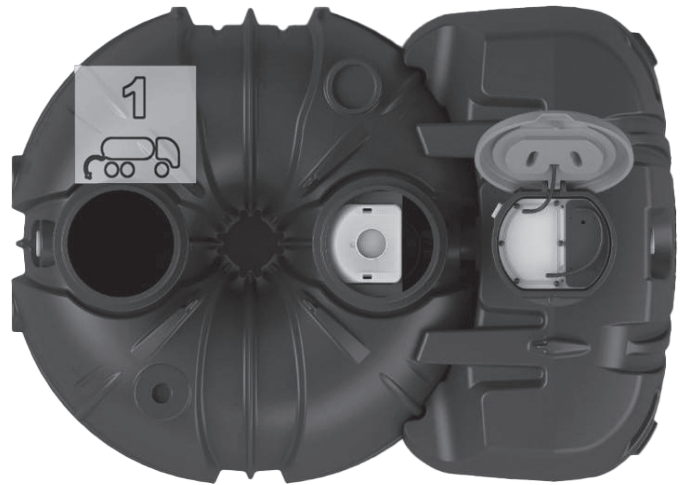

# 12. Sampling

Alternatives for sampling locations (see the picture):

1. Process tank
2. Sampling chamber
3. Discharge pipe

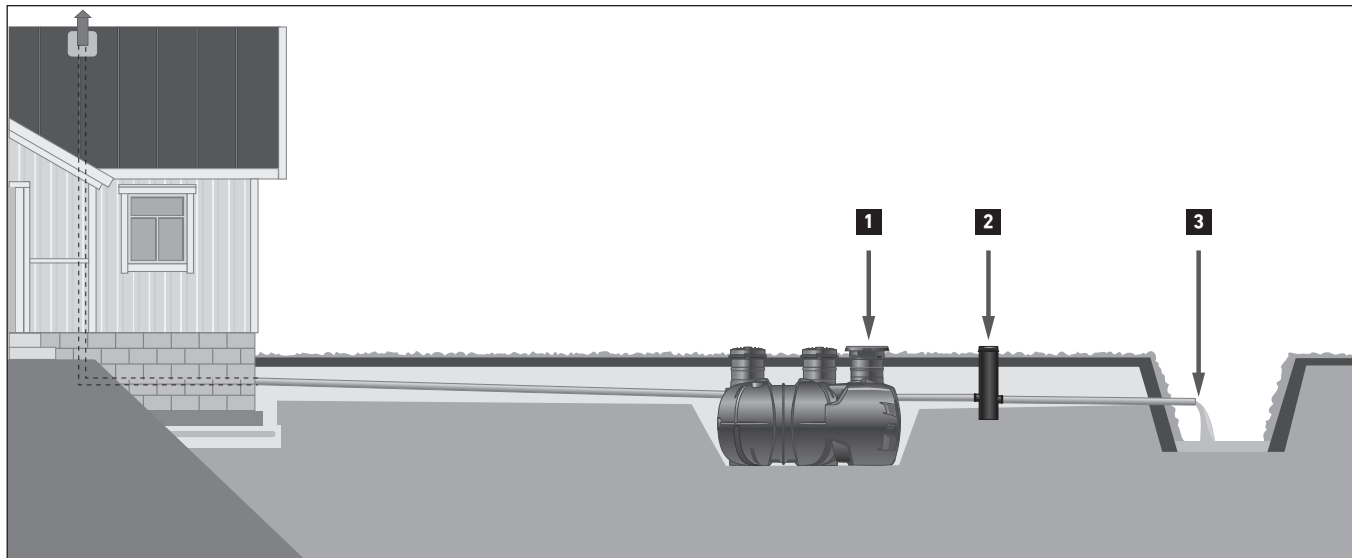

## 1. Process tank

A sample can be taken from the process tank during a cleaning cycle on phase SEDIMENTATION 2. Start sampling preparations by starting manually a cleaning cycle. This is done by turning the power off and back on in the switch cabinet (disconnect and connect back the power plug). SEDIMENTATION 2 starts in 2h 30 min from this power-on. You have 15 min time to take the sample. Before sampling please check by pressing the test button shortly that the display shows S108. This is to secure that process is in the phase SEDIMENTATION 2.

Sample shall be taken from just below the water surface (2–4cm). Be careful that the sampling vessel does not touch the tank walls, modules or air-hoses. There can be solids accumulated on the surfaces.

## 2. Sampling chamber

A sample can be taken at any time from a sampling chamber. In order to get a representative sample the sampling chamber needs to be clean. Be careful when taking the sample so that the sampling vessel doesn't touch the chamber walls. There can be solids accumulated on the surfaces.

## 3. Discharge pipe

If the discharge pipe is visible, the sample can be taken by placing a vessel under the pipe. In order to get the sample on a wanted time the cleaning cycle shall be started manually. This can be done by turning the power off and back on in the switch cabinet (disconnect and connect back the power plug). The cleaning cycle lasts for 3 hours after which the sampling vessel can be collected.

**Note 1!** If there is a high-water alarm on, you shouldn't take a sample.







**Note 2!** If the water level in the septic tank reaches alarm height during the cleaning cycle, the cleaning cycle is shortened and SEDIMENTATION 2 starts earlier than 2 h 30 min after power-on. In that case you have to repeat the sampling procedure later.

Use protective equipment when taking the sample, and take care of hygiene after taking the sample. Carefully follow the instructions of the laboratory analyzing the sample regarding handling, storage and temperature of the water sample.

# 13. Malfunction

The Info panel alerts you to a malfunction in the treatment plant by switching off the green OK light. In addition, the display panel sounds an alarm with a 30-second beep once an hour and indicates an active alarm with a flashing red light.

To acknowledge the alarm, press the OK button, after which the active alarm light stays on and the signal beep turns off. In the event of an alarm, follow the instructions in the table. After the procedure, the alarm light goes out and the OK light comes on. The error code is read from the display on the control centre.

Alarm	Error code	Reason	Consequences	Measures
<b>Wireless connection</b> 	E011	Power failure on the display panel	The display panel does not work	Check the AC adapter
		No connection	The display panel does not work	Activate the connection
		Recurring connection issues	The display panel does not work	Change the location of the display panel
		Power failure in the control centre	The treatment plant is not working	Check the electrical connection
<b>Small amount of the flocculation chemical</b> 	E021	The amount of flocculation chemical in the vessel is small	Phosphorus removal is deteriorating	Fill the vessel with the flocculation chemical
<b>High water level</b> 	E031	Pump-in module blockage	High water level, sludge accumulation	Clean the blockage in the pump-in module
		Excessive water use	Temporary overload	Monitor water usage
	E032	Unloading site/pipe blockage	The treatment plant cannot remove water	Open/defrost the discharge point
		Pump-out blockage	Decreased cleaning power	Clear the pump-out module
	E034	High water level pump well. Used when installed pump well. Pump and/or level switch does not work.	The transfer of waste water to treatment plant failed	Contact Service for repair
	<b>Hardware failure in the control cabinet</b> 	E040	Fault in the compressor	The treatment plant is not working
E041		Fault in the solenoid valve for chemical addition	Phosphorus removal is deteriorating	Contact Service for repair
E042		Fault in the solenoid valve of the sludge removal	Sludge recovery does not work	Contact Service for repair
E043		Fault in the solenoid valve of the pump-out	Pump-out does not work, alarm E032 is activated	Contact Service for repair
E044		Fault in the solenoid valve of the pump-in	The pump-in does not work, alarm E031 is activated	Contact Service for repair
E045		Fault in the solenoid valve for aeration	Disturbance in the cleaning process	Contact Service for repair
E046		Fault in the blower 2 (Clean II)	Disturbance in the cleaning process	Contact Service for repair
E047		Software error	The treatment plant is not working	Contact Service for repair
E048		Dip switch error	The treatment plant is not working	Contact Service for repair
<b>Service reminder</b> 	E401	1-year-service reminder		Order service
	E402	3-year-service reminder		Order service
	E403	6-year-service reminder		Order service
<b>Sludge emptying reminder</b> 	E051	Septic tank filling with sludge	Disturbance in the cleaning process	Empty the septic tank and reset the counter, see instructions on page 15. Press the multifunction button for more than 10 seconds to acknowledge the reminder

## Opening blockages in functional units

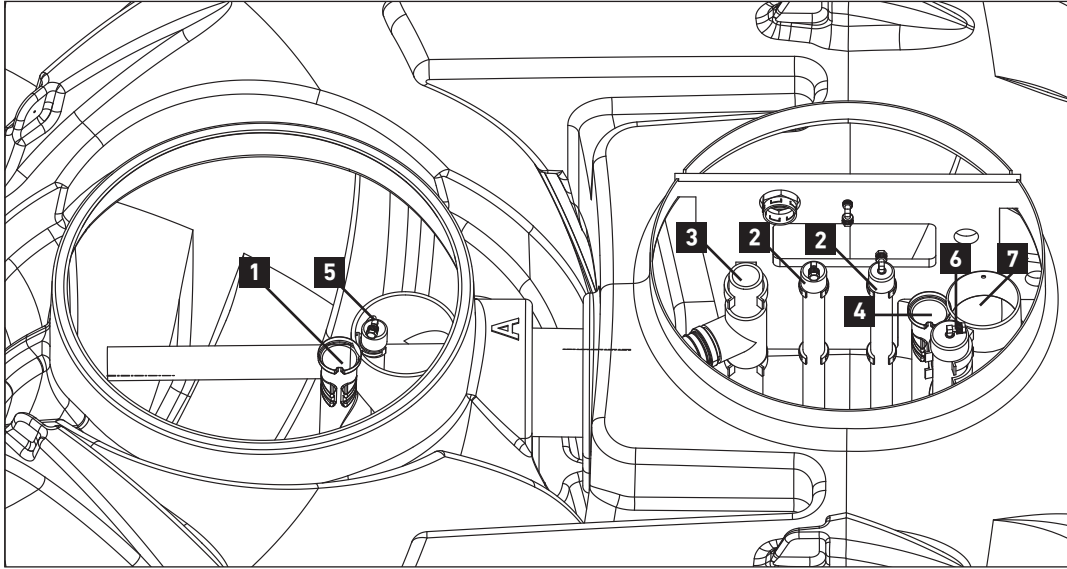

### Filling, sludge removal or emptying unit

If one of the functional units of the treatment plant becomes clogged, the blockage is opened by rinsing with water or compressed air. The flushing hose is inserted into the flushing opening of the clogged functional unit. In the event of a blockage, it should also be checked that no flow obstructions have formed in the discharge pipe or discharge point.

When flushing with compressed air, disconnect the air hose of the flushing unit from the bottom of the control centre. Blow compressed air (max. 4 bar) into the air hose using a separate compressor.

The same method can also be used to test the operation of the unit. Finally, secure the hose in place.

### Alarm and start level unit

If the alarm or start level unit becomes clogged, the blockage can be opened by blowing compressed air into the unit's air hose. Start the test cycle after the procedure, see page 16.

### The functional units of the Uponor Clean II treatment plant

	Functional unit	Air hose colour
1.	The flushing opening of the pump-in unit	Blue
2.	Aeration unit	Gray
3.	Sludge removal unit	Brown
4.	The flushing opening of the pump-out unit	Red
5.	Alarm level unit	Black
6.	Start level unit	Green
7.	The flushing opening of the outlet pipe	-

## DECLARATION OF PERFORMANCE

CPR-5-IWW-1000006

**1. Unique identification code of the product-type:**

*Clean I, small sewage treatment plant, product number 1048256*

*Clean II, small sewage treatment plant, product number 1133828*

**2. Type, batch or serial number or any other element allowing identification of the construction product as required pursuant to Article 11(4):**

*n/a*

**3. Intended use or uses of the construction product, in accordance with the applicable harmonised technical specification, as foreseen by the manufacturer:**

*Domestic wastewater treatment for one and two households.*

**4. Name, registered trade name or registered trademark and contact address of the manufacturer as required pursuant to Article 11(5):**

*Uponor Infra AB, Industrivägen 11, 513 32 Fristad, Sweden*

**5. Where applicable, name and contact address of the authorised representative whose mandate covers the tasks specified in Article 12(2):**

*Uponor Infra Oy, FIN-15561 Nastola, Finland*

*Uponor Infra A/S, DK-4450 Jyderup, Denmark*

*Uponor Infra AS, N-0195 Oslo, Norway*

*Uponor Infra AS, 13811 Tallinn, Estonia*

*Uponor Latvia SIA, LV-1045 Riga, Latvia*

*Uponor UAB, LT-06115 Vilnius, Lithuania*

**6. System or systems of assessment and verification of constancy of performance of the construction product as set out in Annex V:**

*System 3*

**7. In case of the declaration of performance concerning a construction product covered by a harmonized standard:**

*EN 12566-3: 2005+A2:2013*

*Initial type testing of product under system 3 performed by:*

- *SP, Box 857, 50115 Borås, Sweden, Notified Body No. 0402  
Test reports: P 901876-01, P 901876-02 and P 901876-03*
- *Finnish Environment Institute (SYKE), Box 140 Helsinki, Finland, Notified Body No. 1762  
Test reports: SYKE-2004-A-3-A4/34EN, Collected results of EN-testing (SYKE-2004-A-3-A4/31, SYKE-2004 A-3-A4/26)*
- *Eurofins, Box 47, FI-02151 Espoo, Finland, Notified Body No. 0809  
Test report: EUFI29-21004088-T1*

**8. In case of the declaration of performance concerning a construction product for which a European Technical Assessment has been issued:**

*n/a*

### 9. Declared performance

 13			
Essential characteristics	Performance	Harmonized technical specification	
<b>Effectiveness of treatment expressed as:</b>		EN 12566-3:2005+A2:2013	
Treatment efficiency	COD: 95 % BOD7: 98 % SS: 98 % Total nitrogen: 50 % Total phosphorus: 96 % Tested organic daily load 0,2kg BOD <sub>7</sub> /d		
<b>Treatment capacity</b>	<b>Clean I</b>		<b>Clean II</b>
Nominal organic daily load	0,42 kg/d		0,60 kg/d
Nominal hydraulic daily flow	0,84 m <sup>3</sup> /d		1,80 m <sup>3</sup> /d
Max hydraulic daily flow	1,05 m <sup>3</sup> /d		2,10 m <sup>3</sup> /d
Nominal designation	7 pe		12 pe
<b>Power consumption</b>	0,9 kWh/d		1,6 kWh/d
<b>Watertightness</b>	Pass (Water test)		
<b>Crushing resistance</b>			
Load bearing capacity	Height of backfill 1,0 m, WET 1,3 m		
<b>Durability</b>	Pass (PE)		
<b>Reaction to fire</b>	NPD		
<b>Release of dangerous substance</b>	NPD		

10. The performance of the product identified in point 1 is in conformity with the declared performance in point 9.

This declaration of performance is issued under the sole responsibility of the manufacturer identified in point 4.

Signed for and on behalf of the manufacturer by:



**Niila Tast**  
**Application Manager IWW**  
Date: 2025-04-07

# Contact information

System Owner	
Name	System installation date
Address	
	System activation date

System Designer	
Name	Phone
Address	
	E-mail

System Vendor	
Name	Phone
Address	
	E-mail

System Installer	
Name	Phone
Address	
	E-mail

Service Company	
Name	Phone
Address	
	E-mail

Building Authority	
Name	Phone
Address	
	E-mail

Environmental Authority	
Name	Phone
Address	
	E-mail

SAFETY DATA SHEET

## CLEAN FLOCCULATION CHEMICAL

### SECTION 1: Identification of the substance/mixture and of the company/undertaking

1.1. Product identifier

Trade name

CLEAN FLOCCULATION CHEMICAL

Unique formula identifier (UFI)

YDDN-2VKH-5205-QV4S

1.2. Relevant identified uses of the substance or mixture and uses advised against

Relevant identified uses of the substance or mixture

Water treatment agent., Flocculant

Uses advised against

None known.

1.3. Details of the supplier of the safety data sheet

Company and address

**UPONOR INFRA AB**

Industrivägen 11

51332 Fristad

Sweden

+46 33-172500

www.uponor.se

E-mail

info@uponor.com

Revision

04/06/2024

SDS Version

1.0

1.4. Emergency telephone number

In case of emergency dial 112 and ask for Poison Information both day and night.

For less urgent questions dial 010-456 6700 both day and night.

### SECTION 2: Hazards identification

Classified according to Regulation (EC) No. 1272/2008 (CLP).

2.1. Classification of the substance or mixture

Met. Corr. 1; H290, May be corrosive to metals.

Eye Dam. 1; H318, Causes serious eye damage.

2.2. Label elements

Hazard pictogram(s)



Signal word

Danger

Hazard statement(s)

May be corrosive to metals. (H290)

Causes serious eye damage. (H318)

Precautionary statement(s)

General

If medical advice is needed, have product container or label at hand. (P101)

Keep out of reach of children. (P102)

Prevention

Keep only in original packaging. (P234)

Wear eye protection/protective gloves/protective clothing. (P280)

Response

IF IN EYES: Rinse cautiously with water for several minutes. Remove contact lenses, if present and easy to do. Continue rinsing. (P305+P351+P338)  
 Immediately call a POISON CENTER/doctor. (P310)  
 Absorb spillage to prevent material damage. (P390)

Storage

-

Disposal

Dispose of contents/container in accordance with national regulation / in accordance with local regulation (P501)

Hazardous substances

Aluminium chloride, basic / Polyaluminium chloride

Additional labelling

UFI: YDDN-2VKH-5205-QV4S

2.3. Other hazards

Additional warnings

This mixture/product does not contain any substances known to fulfil the criteria for PBT and vPvB classification. This product does not contain any substances considered to be endocrine disruptors in accordance with the criteria set out in Commission Delegated Regulation (EU) 2017/2100 or Commission Regulation (EU) 2018/605.

### SECTION 3: Composition/information on ingredients

3.1. Substances

Not applicable. This product is a mixture.

3.2. Mixtures

Product/substance	Identifiers	% w/w	Classification	Note
Aluminium chloride, basic / Polyaluminium chloride	CAS No.: 1327-41-9 EC No.: 215-477-2 REACH: 01-2119531563-43 Index No.:	25 - 50%	Met. Corr. 1, H290 Eye Dam. 1, H318	

See full text of H-phrases in section 16. Occupational exposure limits are listed in section 8, if these are available.

Other information

-

### SECTION 4: First aid measures

4.1. Description of first aid measures

General information

In the case of accident: Contact a doctor or casualty department – take the label or this safety data sheet. Contact a doctor if in doubt about the injured person's condition or if the symptoms persist. Never give an unconscious person water or other drink.

Inhalation

Upon breathing difficulties or irritation of the respiratory tract: Bring the person into fresh air and stay with him/her.

Skin contact

Upon irritation: rinse with water. In the event of continued irritation, seek medical assistance.

Eye contact

If in eyes: Flush eyes with plenty of water or salt water (20-30 °C) for at least 30 minutes and continue until irritation stops. Remove contact lenses. Make sure you flush under the upper and lower eyelids. Seek medical assistance immediately and continue flushing during transport.

Ingestion

If the person is conscious, rinse the mouth with water and stay with the person. Never give the person anything to drink.

In case of malaise, seek medical advice immediately and bring the safety data sheet or label from the product. Do not induce vomiting, unless recommended by the doctor. Have the person lean forward with head down to avoid inhalation of or choking on vomited material.

Burns

Not applicable.

4.2. Most important symptoms and effects, both acute and delayed

The product contains substances that cause serious eye damage. Contact with these substances can cause irreversible effects on the eye / serious eye damage.

4.3. Indication of any immediate medical attention and special treatment needed

IF exposed or concerned:

Get immediate medical advice/attention.

Information to medics

Bring this safety data sheet or the label from this product.

## SECTION 5: Firefighting measures

5.1. Extinguishing media

Suitable extinguishing media: Alcohol-resistant foam, carbon dioxide, powder, water mist.

Unsuitable extinguishing media: Waterjets should not be used, since they can spread the fire.

5.2. Special hazards arising from the substance or mixture

Fire will result in dense smoke. Exposure to combustion products may harm your health. Closed containers, which are exposed to fire, should be cooled with water. Do not allow fire-extinguishing water to enter the sewage system and nearby surface waters.

5.3. Advice for firefighters

Wear self-contained breathing apparatus and protective clothing to prevent contact. Upon direct exposure contact the National Poisons Information Centre (NPIC) on +353 (0) 1 809 256 (24 h service) in order to obtain further advice.

## SECTION 6: Accidental release measures

6.1. Personal precautions, protective equipment and emergency procedures

Avoid direct contact with spilled substances.

Contaminated areas may be slippery.

6.2. Environmental precautions

Avoid discharge to lakes, streams, sewers, etc.

Keep unauthorized persons away from the spill

6.3. Methods and material for containment and cleaning up

Contain and collect spillage with non-combustible, absorbent material e.g. sand, earth, vermiculite or diatomaceous earth and place in container for disposal according to local regulations.

Wherever possible cleaning should be performed with normal cleaning agents. Avoid use of solvents.

6.4. Reference to other sections

See section 13 "Disposal considerations" on handling of waste.

See section 8 "Exposure controls/personal protection" for protective measures.

## SECTION 7: Handling and storage

7.1. Precautions for safe handling

Avoid direct contact with the product.

Smoking, drinking and consumption of food is not allowed in the work area.

See section 8 "Exposure controls/personal protection" for information on personal protection.

7.2. Conditions for safe storage, including any incompatibilities

Containers that have been opened must be carefully resealed and kept upright to prevent leakage.

Store in a container with a resistant inner liner.

Recommended storage material

Plastic

Keep only in original packaging.

Storage conditions

0 - 30°C

Incompatible materials

Bases

7.3. Specific end use(s)

This product should only be used for applications quoted in section 1.2.

## SECTION 8: Exposure controls/personal protection

8.1. Control parameters

No substances are listed in the "List of Chemical Agents and Occupational Exposure Limit Values" with an occupational exposure limit.

DNEL

Aluminium chloride, basic / Polyaluminium chloride

Duration:	Route of exposure:	DNEL:
Long term – Systemic effects - General population	Dermal	2.32 mg/kg bw/day
Long term – Systemic effects - Workers	Dermal	4.6 mg/kg bw/day
Long term – Systemic effects - General population	Inhalation	4 mg/m <sup>3</sup>
Long term – Systemic effects - Workers	Inhalation	16.4 mg/m <sup>3</sup>
Long term – Systemic effects - General population	Oral	2.3 mg/kg bw/day

PNEC

No data available.

8.2. Exposure controls

Apply general control to prevent unnecessary exposure

General recommendations

Smoking, drinking and consumption of food is not allowed in the work area.

Exposure scenarios

There are no exposure scenarios implemented for this product.

Exposure limits

Occupational exposure limits have not been defined for the substances in this product.

Appropriate technical measures

Ensure that eyewash stations and safety showers are located within easy reach.

Apply standard precautions during use of the product. Avoid inhalation of vapours.

Hygiene measures

In between use of the product and at the end of the working day all exposed areas of the body must be washed thoroughly. Pay special attention to hands, forearms and face.

Measures to avoid environmental exposure

No specific requirements.

Individual protection measures, such as personal protective equipment

Generally

Use only CE marked protective equipment.



Respiratory Equipment

Type	Class	Colour	Standards	
NR	P2	White	EN143	

Skin protection

Recommended	Type/Category	Standards	
Dedicated work clothing should be worn. Wear a protective suit in the event of prolonged periods of work with the product.	-	-	

Hand protection

Material	Glove thickness (mm)	Breakthrough time (min.)	Standards	
Vinyl/PVC	0,5	> 480	EN374-3, EN388	
Neoprene (Neoprene)	0,6	> 480	EN374-2, EN374-3, EN388	

Eye protection

Type	Standards	
Safety glasses	EN166	

## SECTION 9: Physical and chemical properties

### 9.1. Information on basic physical and chemical properties

Physical state

Liquid

Colour

Yellowish

Odour / Odour threshold

Mild

pH

~ 1,5

Density (g/cm<sup>3</sup>)

1,28 - 1,34

Kinematic viscosity

No data available

Dynamic viscosity

10 - 30 mPa.s (23 °C)

Particle characteristics

Not applicable - product is a liquid

Phase changes

Melting point/Freezing point (°C)

~ 30

Softening point/range (waxes and pastes) (°C)

Does not apply to liquids.

Boiling point (°C)

100 - 120

Vapour pressure

Not applicable

Relative vapour density

Not applicable

Decomposition temperature (°C)

> 200

Data on fire and explosion hazards

Flash point (°C)

Not applicable

Flammability (°C)

Not applicable

Auto-ignition temperature (°C)

Not applicable

Lower and upper explosion limit (% v/v)

Testing not relevant or not possible due to the nature of the product.

Solubility

Solubility in water

Completely soluble

n-octanol/water coefficient (LogKow)

Not applicable - inorganic material

Solubility in fat (g/L)

Not applicable

### 9.2. Other information

Evaporation rate (n-butylacetate = 100)

No data available

Other physical and chemical parameters

No data available.

Oxidizing properties

Not applicable

## SECTION 10: Stability and reactivity

### 10.1. Reactivity

No data available.

10.2. Chemical stability

The product is stable under the conditions, noted in section 7 "Handling and storage".

10.3. Possibility of hazardous reactions

None known.

10.4. Conditions to avoid

Frost

Extremes of temperature

10.5. Incompatible materials

Bases

10.6. Hazardous decomposition products

The product is not degraded when used as specified in section 1.

SECTION 11: Toxicological information

11.1. Information on hazard classes as defined in Regulation (EC) No 1272/2008

Acute toxicity

Product/substance	Aluminium chloride, basic / Polyaluminium chloride
Test method:	OECD 401
Species:	Rat
Route of exposure:	Oral
Result:	> 2000 mg/kg

Product/substance	Aluminium chloride, basic / Polyaluminium chloride
Test method:	OECD 403
Species:	Rat
Route of exposure:	Inhalation
Test:	LC50
Result:	> 5 mg/L

Product/substance	Aluminium chloride, basic / Polyaluminium chloride
Test method:	OECD 402
Species:	Rat
Route of exposure:	Dermal
Test:	LC50
Result:	> 2000 mg/kg

Skin corrosion/irritation

Based on available data, the classification criteria are not met.

Serious eye damage/irritation

Causes serious eye damage.

Respiratory sensitisation

Based on available data, the classification criteria are not met.

Skin sensitisation

Based on available data, the classification criteria are not met.

Germ cell mutagenicity

Based on available data, the classification criteria are not met.

Carcinogenicity

Based on available data, the classification criteria are not met.

Reproductive toxicity

Based on available data, the classification criteria are not met.

STOT-single exposure

Based on available data, the classification criteria are not met.

STOT-repeated exposure

Based on available data, the classification criteria are not met.

Aspiration hazard

Based on available data, the classification criteria are not met.

11.2. Information on other hazards

Long term effects

The product contains substances that cause serious eye damage. Contact with these substances can cause irreversible effects on the eye / serious eye damage.

Endocrine disrupting properties

This mixture/product does not contain any substances known to have hormone-disrupting properties in relation to health.

Other information

None known.

## SECTION 12: Ecological information

### 12.1. Toxicity

Product/substance Aluminium chloride, basic / Polyaluminium chloride  
 Test method: OECD 203  
 Species: Fish, Danio rerio  
 Duration: 96 hours  
 Result: > 1000 mg/L

Product/substance Aluminium chloride, basic / Polyaluminium chloride  
 Test method: OECD 202  
 Species: Daphnia, Daphnia magna  
 Test: EC50  
 Result: 98 mg/L

Product/substance Aluminium chloride, basic / Polyaluminium chloride  
 Test method: OECD 201  
 Species: Algae, Pseudokirchneriella subcapitata  
 Duration: 72 hours  
 Test: EC50  
 Result: 14 mg/L  
 Other information: Read-across (Analogy)

Product/substance Aluminium chloride, basic / Polyaluminium chloride  
 Test method: OECD 202  
 Species: Algae, Pseudokirchneriella subcapitata  
 Duration: 72 hours  
 Test: EC50  
 Result: 0.24 mg/L

Product/substance Aluminium chloride, basic / Polyaluminium chloride  
 Test method: OECD 201  
 Species: Algae, Pseudokirchneriella subcapitata  
 Duration: 72 hours  
 Test: NOEC  
 Result: 1 mg/L

Product/substance Aluminium chloride, basic / Polyaluminium chloride  
 Test method: OECD 201  
 Species: Algae, Pseudokirchneriella subcapitata  
 Duration: 72 hours  
 Test: NOEC  
 Result: < 0.02 mg/L

### 12.2. Persistence and degradability

Based on available data, the classification criteria are not met.

### 12.3. Bioaccumulative potential

Product/substance Aluminium chloride, basic / Polyaluminium chloride  
 Conclusion: No potential for bioaccumulation

### 12.4. Mobility in soil

No data available.

### 12.5. Results of PBT and vPvB assessment

This mixture/product does not contain any substances known to fulfil the criteria for PBT and vPvB classification.

### 12.6. Endocrine disrupting properties

This mixture/product does not contain any substances considered to have endocrine-disrupting properties in relation to the environment.

### 12.7. Other adverse effects

None known.

## SECTION 13: Disposal considerations

### 13.1. Waste treatment methods

Product is covered by the regulations on hazardous waste.  
 HP 4 - Irritant (skin irritation and eye damage)

Commission Regulation (EU) No 1357/2014 of 18 December 2014 on waste.



EWC code

Not applicable.

Contaminated packing

Packaging containing residues of the product must be disposed of similarly to the product.

## SECTION 14: Transport information

	14.1 UN / ID	14.2 UN proper shipping name	14.3 Hazard class(es)	14.4 PG*	14.5 Env**	Other information:
ADR	UN3264	CORROSIVE LIQUID, ACIDIC, INORGANIC, N.O.S. (Polyaluminium chloride)	Transport hazard class: 8 Label: 8 Classification code: C1 	III	No	Limited quantities: 5 L Tunnel restriction code: (E) See below for additional information.
IMDG	UN3264	CORROSIVE LIQUID, ACIDIC, INORGANIC, N.O.S. (Polyaluminium chloride)	Transport hazard class: 8 Label: 8 Classification code: C1 	III	No	Limited quantities: 5 L EmS: F-A S-B See below for additional information.
IATA	UN3264	CORROSIVE LIQUID, ACIDIC, INORGANIC, N.O.S. (Polyaluminium chloride)	Transport hazard class: 8 Label: 8 Classification code: C1 	III	No	See below for additional information.

\* Packing group

\*\* Environmental hazards

Additional information

ADR / See Table A, section 3.2.1 for any information on special provisions, requirements, or warnings in connection with transport. See section 5.4.3, for instructions in writing regarding mitigation of damages in relation to incidents or accidents during transport.

IMDG / See section 3.2.1, for any information on special provisions, requirements, or warnings in connection with transport.

IATA / See Table 4.2 for any information on special provisions, requirements, or warnings in connection with transport.

This product is within scope of the regulations of transport of dangerous goods.

14.6. Special precautions for user

Not applicable.

14.7. Maritime transport in bulk according to IMO instruments

No data available.

## SECTION 15: Regulatory information

15.1. Safety, health and environmental regulations/legislation specific for the substance or mixture

Restrictions for application

No special.

Demands for specific education

No specific requirements.

SEVESO - Categories / dangerous substances

Not applicable.

Additional information

Not applicable.

Sources

Protection of Young Persons (Employment) Act, 1996

Commission Regulation (EU) No 1357/2014 of 18 December 2014 on waste.

Regulation (EC) No 1272/2008 of the European Parliament and of the Council of 16 December 2008 on classification, labelling and packaging of substances and mixtures (CLP).

Regulation (EC) No 1907/2006 of the European Parliament and of the Council of 18 December 2006 concerning the Registration, Evaluation, Authorisation and Restriction of Chemicals (REACH).

15.2. Chemical safety assessment

No

## SECTION 16: Other information

Full text of H-phrases as mentioned in section 3

H290, May be corrosive to metals.

H318, Causes serious eye damage.

Abbreviations and acronyms

ADN = European Provisions concerning the International Carriage of Dangerous Goods by Inland Waterway

ADR = The European Agreement concerning the International Carriage of Dangerous Goods by Road

ATE = Acute Toxicity Estimate

BCF = Bioconcentration Factor

CAS = Chemical Abstracts Service

CE = Conformité Européenne (European conformity)

CLP = Classification, Labelling and Packaging Regulation [Regulation (EC) No. 1272/2008]

CSA = Chemical Safety Assessment

CSR = Chemical Safety Report

DMEL = Derived Minimal Effect Level

DNEL = Derived No Effect Level

EINECS = European Inventory of Existing Commercial chemical Substances

ES = Exposure Scenario

EUH statement = CLP-specific Hazard statement

EuPCS = European Product Categorisation System

EWC = European Waste Catalogue

GHS = Globally Harmonized System of Classification and Labelling of Chemicals

GWP = Global warming potential

IARC = International Agency for Research on Cancer (IARC)

IATA = International Air Transport Association

IBC = Intermediate Bulk Container

IMDG = International Maritime Dangerous Goods

LogPow = logarithm of the octanol/water partition coefficient

MARPOL = International Convention for the Prevention of Pollution From Ships, 1973 as modified by the Protocol of 1978. ("Marpol" = marine pollution)

OECD = Organisation for Economic Co-operation and Development

PBT = Persistent, Bioaccumulative and Toxic

PNEC = Predicted No Effect Concentration

RID = The Regulations concerning the International Carriage of Dangerous Goods by Rail

RRN = REACH Registration Number

SCL = A specific concentration limit

SVHC = Substances of Very High Concern

STOT-RE = Specific Target Organ Toxicity - Repeated Exposure

STOT-SE = Specific Target Organ Toxicity - Single Exposure

TWA = Time weighted average

UN = United Nations

UVBC = Unknown or variable composition, complex reaction products or of biological materials

VOC = Volatile Organic Compound

vPvB = Very Persistent and Very Bioaccumulative

Additional information

The classification of the mixture in regard of health hazards is in accordance with the calculation methods given by Regulation (EC) No. 1272/2008 (CLP).

The safety data sheet is validated by

Uponor Infra AB

Other

A change (in proportion to the last essential change (first cipher in SDS version, see section 1)) is marked with a triangle.

The information in this safety data sheet applies only to this specific product (mentioned in section 1) and is not necessarily correct for use with other chemicals/products.

It is recommended to hand over this safety data sheet to the actual user of the product. Information in this safety

data sheet cannot be used as a product specification.  
Country-language: IE-en





**Uponor Infra Ltd**

Industrivägen 11

513 32 Fristad

T +46 33 172 500

E kundtjanst.infra@uponor.com

We reserve the right to make changes.

30716-EN-06-25\_062025

**[www.uponor.com](http://www.uponor.com)**