

BIOCAT KS 5000-S
BIOCAT KS 5500-S
BIOCAT KS 6500-S
BIOCAT KS 7000-S



BIOCAT KS 5000-S



BIOCAT KS 7000-S

Operating instructions

FailSafe

EN

Table of contents

1	Foreword	4
1.1	Notes to the operating instructions	4
1.2	Safety instructions	4
1.3	Intended use	5
1.4	Warranty	6
1.5	Duty of care of the operator	6
2	Structure and function	8
2.1	Scope of supply and device setup	8
2.2	Description of function	9
2.3	Control and monitoring module	10
3	Technical data	11
4	Installation dimensions	12
5	Installation and Commissioning	13
5.1	Safety instructions and installation conditions	13
5.2	Installation	14
5.3	Installation diagram	15
5.4	Commissioning	18
5.5	Mounting the cover hood	19
6	BCT signal contact (optional accessory)	20
7	Operating modes and indicators	21
7.1	Operating States	22
7.2	Normal operation - water treatment	22
7.3	Thermal disinfection (TD)	23
7.4	Backflushing	25
7.5	Self-test	26
7.6	Battery test	26
7.7	Error messages / malfunctions	27
7.8	Service	29
8	Maintenance	30

1 Foreword

1.1 Notes to the Operating instructions

These operating instructions contain all the important information you will need for the proper operation of the device described. Observing these instructions helps avoid dangers, reduce repair costs and downtime, and increase the reliability and service life of the device.

The operating instructions must always be available at the place of use.

The manufacturer accepts no liability for damage caused by failure to comply with these operating instructions, the applicable regulations or improper use. The risk is borne solely by the user / operator.

For more information or for problems that are not dealt with in detail in these operating instructions, please place a request directly with WATERCryst customer service.

WATERCryst customer service: kundendienst@watercryst.com
AT +43 5232 20602 - 204
DE +49 2129 3475755 - 204

1.2 Safety instructions

The symbols in the operating instructions have the following meaning:



Warning

This symbol indicates information that must be observed to avoid the possibility of extensive property damage. The safety instructions must be followed!



Note

This symbol indicates information regarding the use of the device. Failure to follow this instruction can lead to malfunctions.



Instruction

This symbol indicates a measure that must be observed to ensure correct installation and commissioning.

WATERCryst disclaims all liability if users disregard the notices marked on the equipment and/or in the operating instructions!

1.3 Intended use



BIOCAT KS 5000-S

The BIOCAT KS 5000-S, KS 5500-S, KS 6500-S and KS 7000-S limescale conditioners sustainably reduce limescale build-up in potable water systems and sanitation facilities. The underlying principle of the biomineralisation process protects against limescale build-up without using chemical additives or the electrolytic decomposition of water.

The units are designed to be installed in the main connection of the potable water system of single- and multi-family homes, hospitals, hotels, schools, and other public buildings.

Unit selection and sizing are carried out according to WATERCryst planning documents and design specifications.

The devices are designed exclusively for permanent operation.



The device is not suitable for:

- technical installations for which complete or partial desalination is necessary or prescribed by the manufacturer.
- process water that does not correspond to TVW in its composition.
- water which is highly undersaturated with respect to lime (aggressive to lime) in the area of the treatment unit.
- an operating pressure of the plant greater than 8 bar or less than 2 bar.

The manufacturer accepts no liability for damage caused by failure to comply with these operating instructions, the applicable regulations or improper use. The risk is borne solely by the user / operator.

1.4 Warranty

The warranty is honoured in the sense of our General Terms of Sale and Delivery only if:

- the device is installed by a qualified professional,
- the device is used in accordance with the instructions of this operating manual,
- the device is properly deployed,
- repairs are carried out exclusively by authorised and qualified personnel,
- no unauthorised changes are made to the device.

1.5 Duty of care of the operator

The BIOCAT limescale conditioning system was designed and built under careful observance of harmonised standards and other technical specifications.

The system is thus state of the art and allows maximum safety during all operational states.

The system's safety can only be implemented in practice if all necessary measures are taken. As per the due diligence obligation borne by the operating company, these measures must be planned and their execution controlled.

In particular, the operating company must ensure that

- the system is used only for its intended purpose,
- the system is operated only in a perfectly functioning state, and the safety devices, in particular, are checked regularly for proper functioning,
- the required personal protective equipment is available to and worn by the operational, maintenance and repair personnel,
- the operating manual is always available at the installation site of the device/system, in legible condition and in full,
- only qualified and authorised personnel operate, maintain and repair the system,
- these personnel are regularly instructed in all relevant occupational safety and environmental protection issues and are familiar with the operating instructions and particularly the safety instructions contained therein,
- all safety and warning notices attached to the system remain attached and legible,
- changes to the system are made by authorised and expert personnel only.

2 Structure and function

2.1 Scope of supply and device setup

The units are supplied ready for mounting with a mounting bracket for wall mounting and a cover.

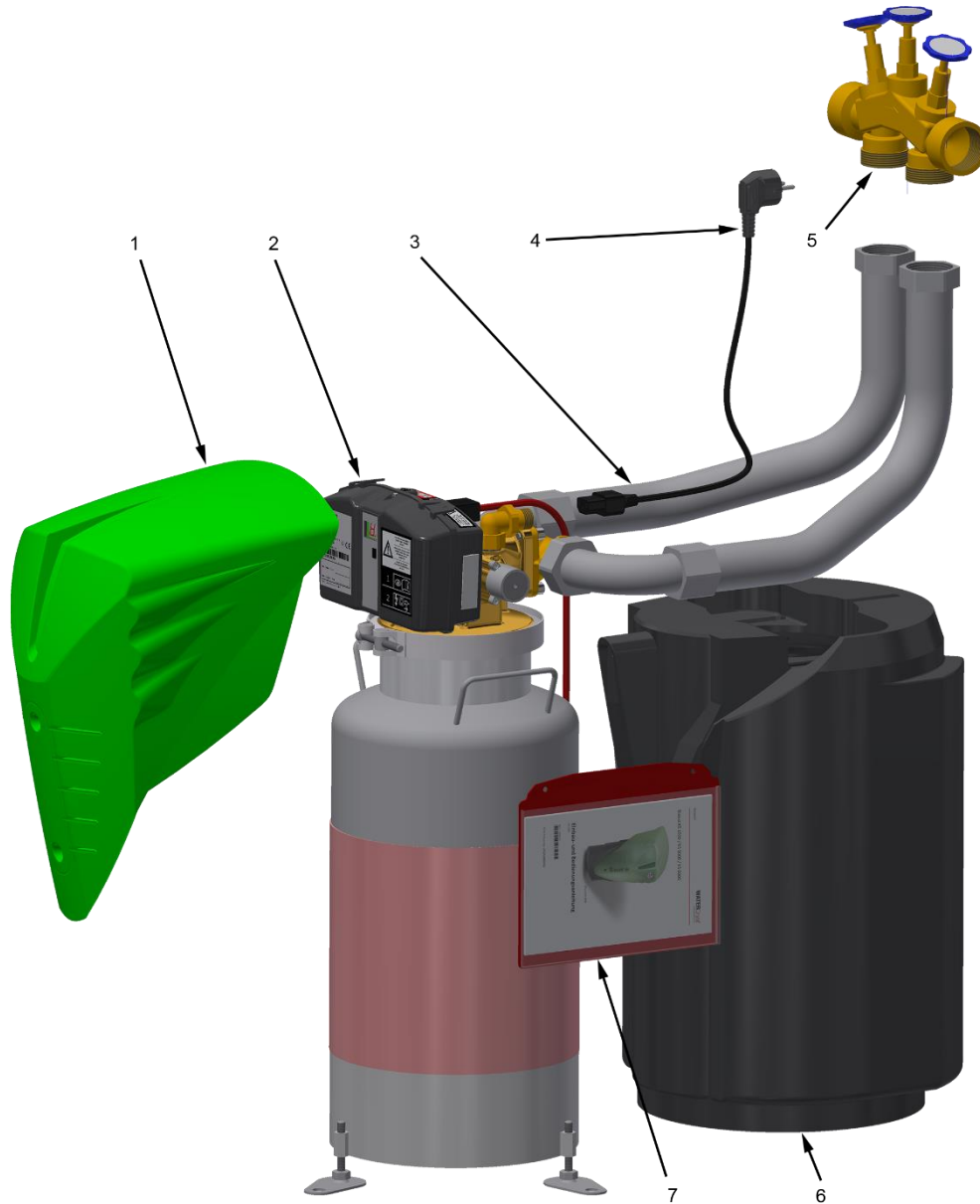

1. Cover bonnet
2. BIOCAT unit
3. Stainless steel connection hoses
4. Mains cable (supplied on commissioning)
5. Bypass fitting
6. Thermal insulation
7. Operating instructions

2.2 Description of function

The functioning of the BIOCAT limescale conditioners is based on the patented WATERCryst catalyst technology. This leaves the valuable minerals in the potable water and does not alter its natural composition.

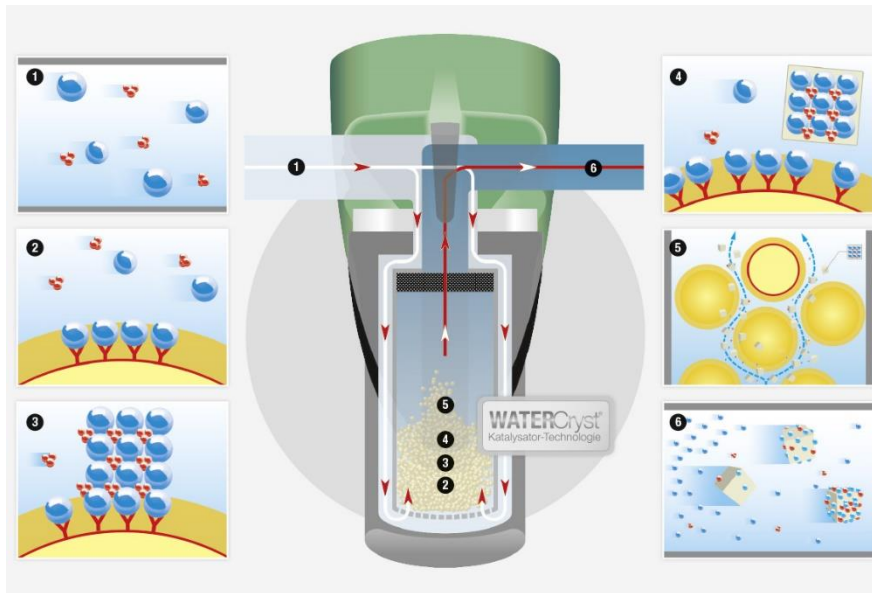

1. Lime (chemically: calcium carbonate CaCO_3) is present in drinking water dissolved in calcium (Ca^{2+}) and carbonate ions (CO_3^{2-}).
2. The BIOCAT lime protection devices include the WATERCryst catalyst granulate, with docking points for calcium and carbonate ions on a specially developed surface.
3. The calcium and carbonate ions are captured by docking points of the granulate and joined together to form the smallest lime crystals. This process takes place independently, without energy or the addition of chemicals. The docking points significantly reduce the activation energy for the formation of lime crystals.
4. When the lime crystals reach a certain size (size reference 10,000ths of a millimetre), they are released from the surface of the granulate by the water flow.
5. The docking points are now free again to build up a new lime crystal from the passing water (the docking points and the granulate do not consume each other and therefore act continuously as a catalyst for the formation of lime crystals). Lime crystals are rinsed inside the BIOCAT limescale protection system with every water withdrawal from the tank and then distributed throughout the drinking water pipe system and the water heaters.
6. The lime crystals now serve as docking points for the excess calcium and carbonate ions in cold and warm water. During tapping, these are finally rinsed out via the fittings. This significantly reduces the formation of lime deposits in pipes and hot water tanks. The water hardness remains unchanged.



BIOCAT limescale conditioners leave the valuable minerals in the potable water. Once the water evaporates from tiles, fittings or shower walls, the minerals are left behind and build up corresponding residues.

Your bathroom and sanitary facilities must therefore be regularly maintained and cleaned. Important information plus tips and tricks can be found on the WATERCryst website www.watercryst.com

2.3 Control and monitoring module

The control and monitoring module provides the following functions:

- Self-test and automatic commissioning
- Monitoring the functioning of the device components
 - Multi-chamber valve position control
 - Heating relay and heating current monitoring of the TD module
 - Temperature monitoring WT, TD and BF
 - Motor function for multi-chamber valve drive
 - Fail-safe (automatic bypass switch during a power failure)
- Status display and alarm output
 - Double-digit display
 - Green, yellow and red light
 - Acoustic alarm
 - Potential-free alarm contact for integration into the building control technology (BCT)
- Operating hours counter
 - Display on service request (granulate replacement after five years)
- Operating elements
 - 'M' and '+' buttons
 - PC interface via USB
- Control elements
 - TD module heating element
 - Temperature sensor
 - Heating-current monitoring
 - Position transducer
 - Battery pack for fail-safe function



3 Technical data

Hydraulic		KS 5000-S	KS 5500-S	KS 6500-S	KS 7000-S
Continuous flow Q_D	[l/h]	125	176	264	375
Nominal flow Q_N	[l/h]	3.800	4.200	5.800	7.000
Nominal pressure	[bar]	PN10			
Operating pressure	[bar]	2-8			
Differential pressure at nominal flow	[bar]	0,245	0,4	0,4	0,45
Max. water temperature	[°C]	25			
Backflushing flow rate (4 bar)	[l/min]	6			
Flushing volume flow rate	[l]	30		39	

Electrical		KS 5000-S	KS 5500-S	KS 6500-S	KS 7000-S
Input power in the treatment mode	[W]	2			
TDI input power	[W]	1.202			
Mains connection	[V/Hz]	230/50			
Plug type		Schuko plug type EF; 2.5m cable length			
Max. ambient temperature	[°C]	25			
Protection class		I			
Protection type		IP20			



Note

The layout of the BIOCAT limescale conditioners must, in principle, adhere to the planning recommendations of WATERCryst. The relevant documents and planning information can be found in our planner documentation.

4 Installation dimensions

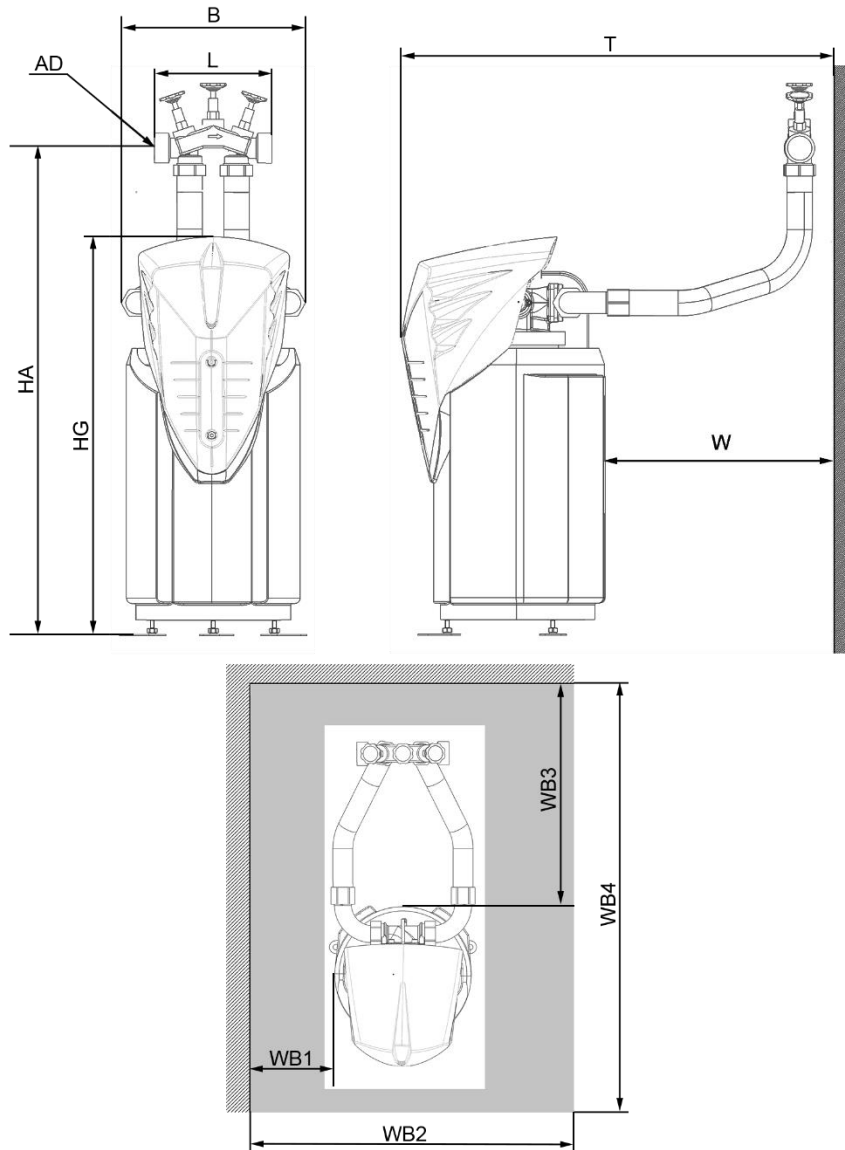

Dimensions		Unit	KS 5000-S	KS 5500-S	KS 6500-S	KS 7000-S
Unit width	B		375		380	
Connection length	L	[mm]	216			
Connection dimension	AD	DN	40 (1 ½")			
Connection height	HA	[mm]	900		1.060	
Unit height	HG	[mm]	725		870	
Depth	T	[mm]	640		675	
Wall distance	W=WB3	[mm]	300			
Maintenance area 1	WB1	[mm]	150			
Maintenance area 2	WB2	[mm]	min. 680			
Maintenance area 4	WB4	[mm]	min. 750			
Weight water filled		[kg]	43	46	53	53
Connection dimension flushing pipe		DN	15 (1/2")			
Discharge dimension		DN	50			

5 Installation and Commissioning

5.1 Safety instructions and installation conditions

Attention!

- When used in potable water installations, note and adhere to all (local) installation regulations, general guidelines and standards for the supply of potable water and heated potable water (TrinkwV, DIN2000, DIN2001, DIN50930, DIN1988, DVGW; ÖVGW or SVGW standards).
- Use the device in proper working condition and for its intended use and in full awareness of safety concerns and possible dangers.
- Observe the installation and operating instructions.
- Faults that can affect safety must be rectified immediately by a specialist.
- Installations and repairs that authorised professionals do not undertake, technical modifications to the device that are not approved in writing by the manufacturer, and the use of non-original spare parts will void the warranty and product liability of the manufacturer.
- The system is designed for a nominal pressure of 10 bar. For the system to function correctly, the operating pressure must be set between a min. of 2 bar and a max. of 8 bar with a commercially available pressure regulating valve.
- The device must be connected to properly installed, grounded and secure single-phase mains electricity (230 V / 50 HZ).
- Insert the plug only after assembly is complete.
- The system must not be exposed to direct moisture. In particular, water dripping from above must be prevented.
- Check the tightness and proper functioning of the system regularly and comply scrupulously with the prescribed inspection and maintenance intervals and the measures provided for this purpose.
- Before performing maintenance or repair work, bar access by unauthorised persons to the working area of the limescale conditioner.
 - Affix or put up an information board that draws attention to the maintenance or repair work.
 - Unplug the device, depressurise the system, and secure against restarting.
 - Before maintenance or repair work, ensure that all device and system parts have cooled down to room temperature.

The device contains a flushing line, which must be run out to a drain. The customer must ensure the unobstructed flow of the runoff water at all times.

Attention: Load-lifting equipment must be secured against power failure.

5.2 Installation



The operating pressure must be at least 2 bar and may not exceed 8 bar. If necessary, a pressure-reducing valve is to be installed upstream of the device.

In the case of a continuous water withdrawal (e. g. swimming pool filling, irrigation) a separate outlet must be provided upstream of the BIOCAT KS for this purpose!

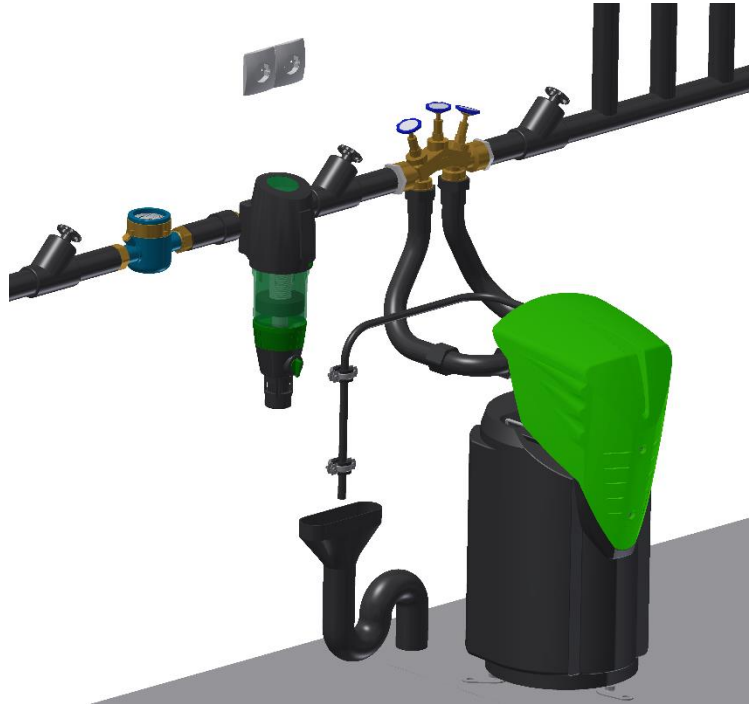

Installation example of a BIOCAT KS 5000-S in the cold water connection of a multi-residential building downstream of the water meter, filter, and pressure regulator.



Any other use of the device or use beyond what is specified is considered to be **IMPROPER USE!**

The manufacturer / supplier assumes no liability for damage caused by disregarding these operating instructions or the regulations or for damage caused by improper use. The user / operator bears sole risk.

5.3 Installation diagram

Installation is carried out on the cold water supply line.



The operating pressure must be at least 2 bar and may not exceed 8 bar. If necessary, a pressure-reducing valve is to be installed upstream of the device.

Option A: Protection of the entire drinking water installation

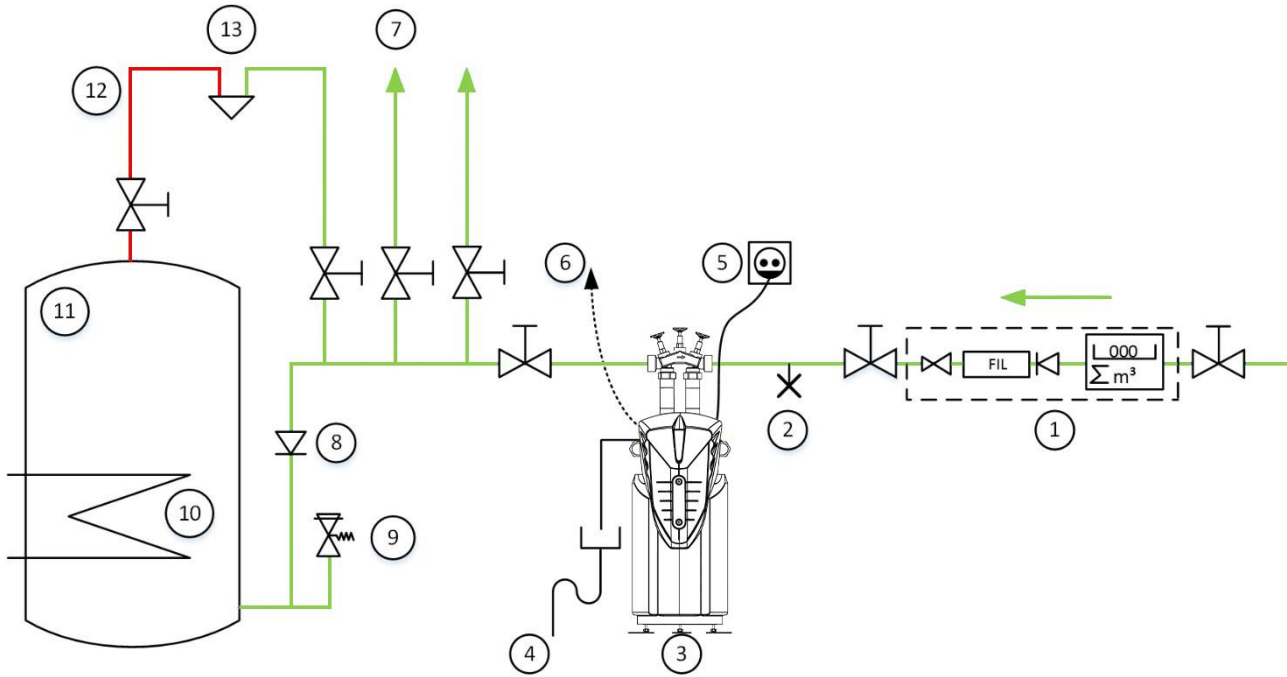

(1) Water meter + domestic water station; (2) Drain valve; (3) BIOCAT limescale conditioner; (4) Free outlet into drain; (5) Flushing line (temperature resistant 80°C); (6) Socket outlet; (7) Optional: integration into building routing technology using a signal contact; (8) check valve; (9) pressure relief valve; (10) Heat exchanger; (11) hot water tank; (12) hot water distributor with hot water riser; (13) wall-mounted mixer tap; (14) cold water distributor with cold water riser

Variant B: Protection for the hot water installation

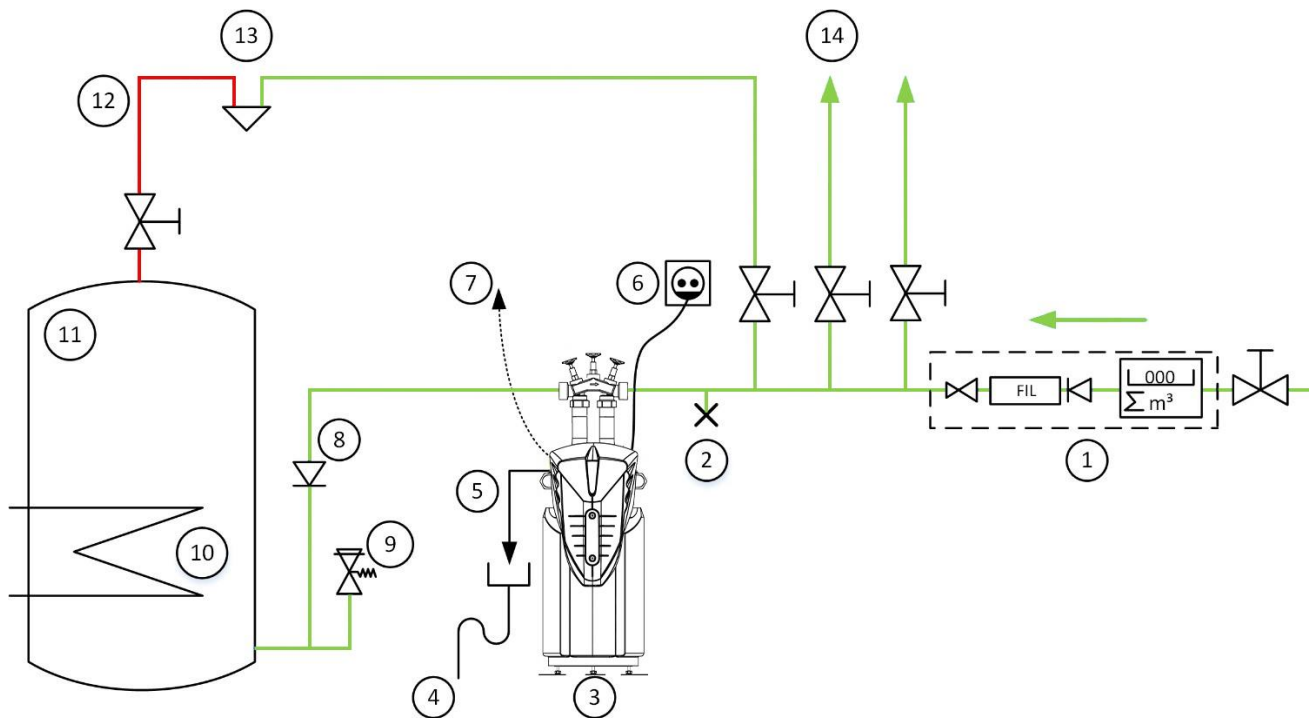

(1) Water meter + domestic water station; (2) Drain valve; (3) BIOCAT limescale conditioner; (4) Free outlet into drain; (5) Flushing line (temperature resistant 80°C); (6) Socket outlet; (7) Optional: integration into building routing technology using a signal contact; (8) check valve; (9) pressure relief valve; (10) Heat exchanger; (11) hot water tank; (12) hot water distributor with hot water riser; (13) wall-mounted mixer tap; (14) cold water distributor with cold water riser



The built-in schema does not contain all the shut-off and safety components required for professional assembly of the device, but only those components essential for the correct installation of the device. Applicable standards, particularly the DIN 1988 and local installation guidelines, must be observed.

Variant C: Protection of a drinking water reservoir and subsequent drinking water installation

Install the BIOCAT KS unit in the cold water inlet of a drinking water reservoir!

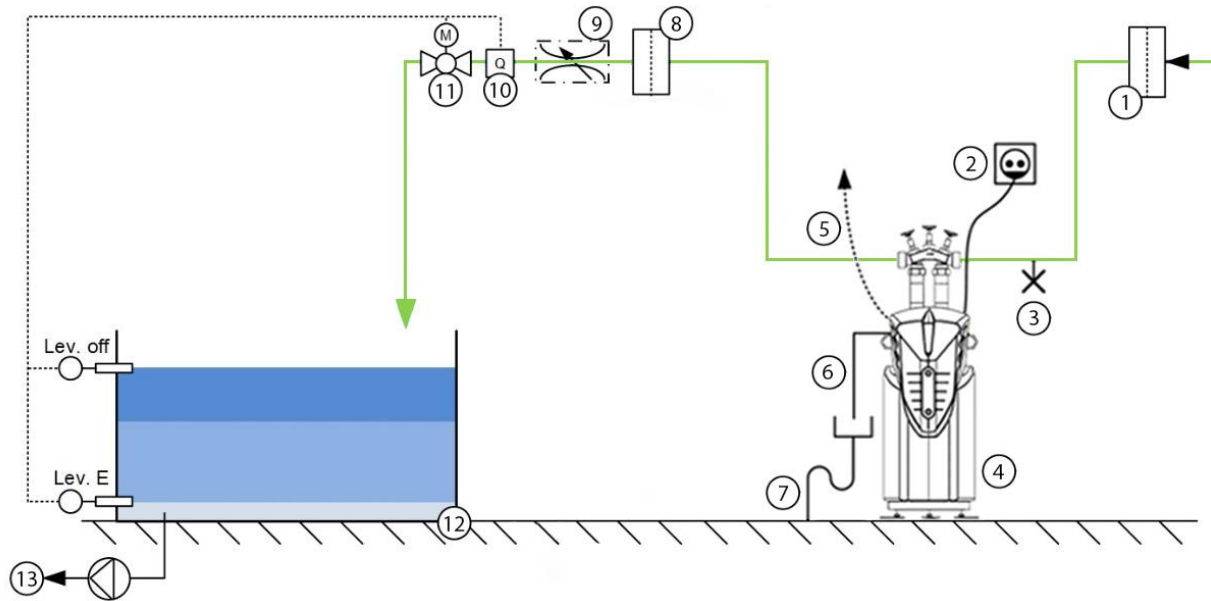

(1) pre-filter; (2) socket 230V 50Hz; (3) drain cock; (4) BIOCAT KS limescale protection device; (5) optional: integration into the building management system by means of signal contact; (6) backwash line (temperature resistant 80°C); (7) free outlet into drain; (8) fine filter; (9) flow limiter; (10) flow measurement; (11) shut-off unit; (12) drinking water reservoir; (13) consumer



The installation diagram does not contain all the shut-off and safety devices required for proper installation, but only the essential components for proper installation of the unit. Relevant standards, in particular DIN 1988 and local installation guidelines, must be observed.



The selection of the unit size is chosen according to the refill volume flow of the drinking water reservoir.
BIOCAT continuous flow rate $Q_D \geq$ refill volume flow Q_{Refill}
 The set value of the flow limiter must not exceed the continuous flow rate of the BIOCAT.

5.4 Commissioning



Commissioning is carried out exclusively by WATERCryst customer service. Otherwise, WATERCryst excludes any warranty and guarantee!

5.4.1 Preparation



Before commissioning, check all connections for proper fitting and tightness!

According to regulations, the flushing line from the unit to the drain must be installed.

Check whether there is a properly grounded and fused socket within reach of the supplied cable.

5.4.2 Putting the device into operation

1. Connect the water supply and open the maintenance valves upstream and downstream of the BIOCAT limescale conditioner

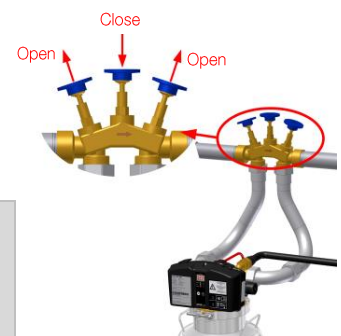

The bypass **MUST** be closed!
If it is not closed, the water treatment cannot be guaranteed!

2. Connect the heating plug (red cable) to the control system
3. Connect the mains cable to the control system and plug it into the power outlet



On inserting, a **battery test** starts automatically:

Status-No.: 05 (battery test)
LED: green



4. „Press the ‘M’ button, hold for **two seconds**, and release again.
→ *Count: Twenty-one, twenty-two*

The control system starts automatically with a commissioning routine.



press button for 2
seconds!

Status-No.: 04. / Selftest

→ Check the unit for leaks at the same time!

Decimal point on the display flashes

LED: green

Duration approx. 3-4 min.



INDICATION:

Please **DO NOT** leave the limescale conditioning system unattended, and **DO NOT** unplug it as long as the decimal point is flashing!

While the decimal point is flashing, the device is automatically filling up with water, and all the important functions are being checked:

5. Multi-chamber valve drive
6. Position indicator
7. The slider is moved into the backflushing position
→ the device is automatically aerated
8. Heating element for thermal disinfection
9. Check the dimensioning of the drain!
Flushing is repeated several times

After the self-test, a TD is automatically started.

Status no.: 02. / thermal disinfection

INDICATION:

Please **DO NOT** leave the limescale conditioning system unattended, and **DO NOT** unplug it as long as the decimal point is flashing!



-
10. Once the decimal point is no longer illuminated, the BIOCAT limescaling conditioner can be left unattended.

DONE!

The valve spool is now in the secure TD position, and a thermal disinfection is carried out.



5.5 Mounting the cover hood



Visual inspection for leaks!

Before mounting the cover hood, check the installation and device for leaks.

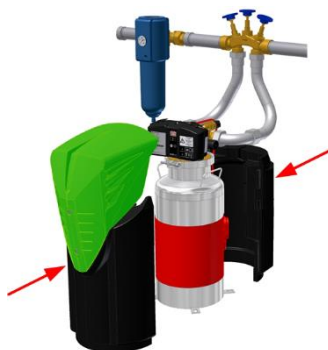

6 BCT signal contact (optional accessory)

	Article	Description	Art.-Nr.
	BCT signal contact including cable L=5m	Connector for integrating the BIOCAT limescale protection system into the building management system (BTC) Details see: → Electrical connection → BCT	12000122

Example circuit 1: with external signal lamp

Potential-free relay contact:
max. 24V 1A, max. 1 mm²

The contact is closed during malfunction-free operation.

During a malfunction or power failure, the contact is opened.

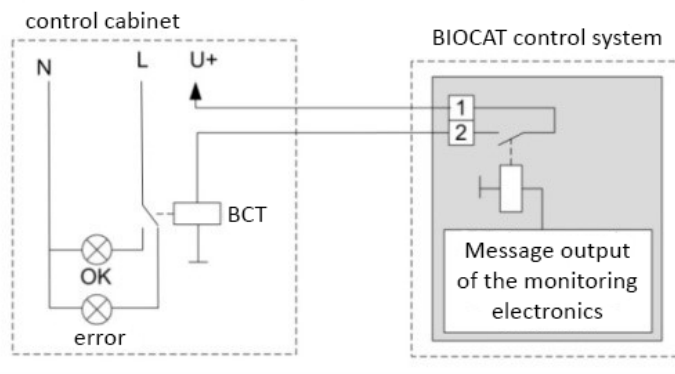

Example circuit 2: Integration into BCT (digital input)

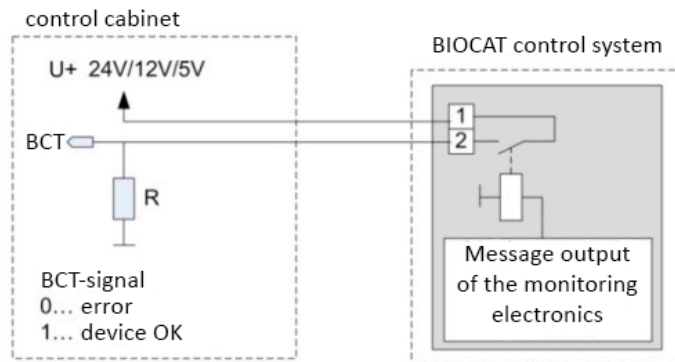

7 Operating modes and indicators



The control electronics indicates the respective operating conditions and malfunctions through a double-digit display, three LEDs and an acoustic signal transmitter (buzzer).

Display:

- displays the current operating mode or the error number



- ACTIVE
- CAT
- ERROR

Operating status lights:

- green „ACTIVE“ (malfunction-free operation)
- yellow „CAT“ (cartridge replacement required)
- red „Error“ (malfunction/error)

Legend

- Display – status number
- LED lights up
- LED flashes once per second
- LED is dark (unlit)

Acoustic alarm for:

- Errors
- Service request
- On plugging in



Legend

- Buzzer on
- Buzzer off

Signal contact (BCT)

BCT-Signal: 1

Legend

- BCT-Signal: 1 Contact closed
- BCT-Signal: 0 Contact open

7.1 Operating States

01	Green / ACTIVE	Water treatment active
02	Green / ACTIVE	Thermal disinfection active
03	Green / ACTIVE	Backflushing active
04	Green / ACTIVE	Self-test active
05	Green / ACTIVE	Battery test active
06	Red / ERROR blinks	Fail-safe active: no mains supply!
11		HW-test mode (for customer service only)

7.2 Normal operation - water treatment

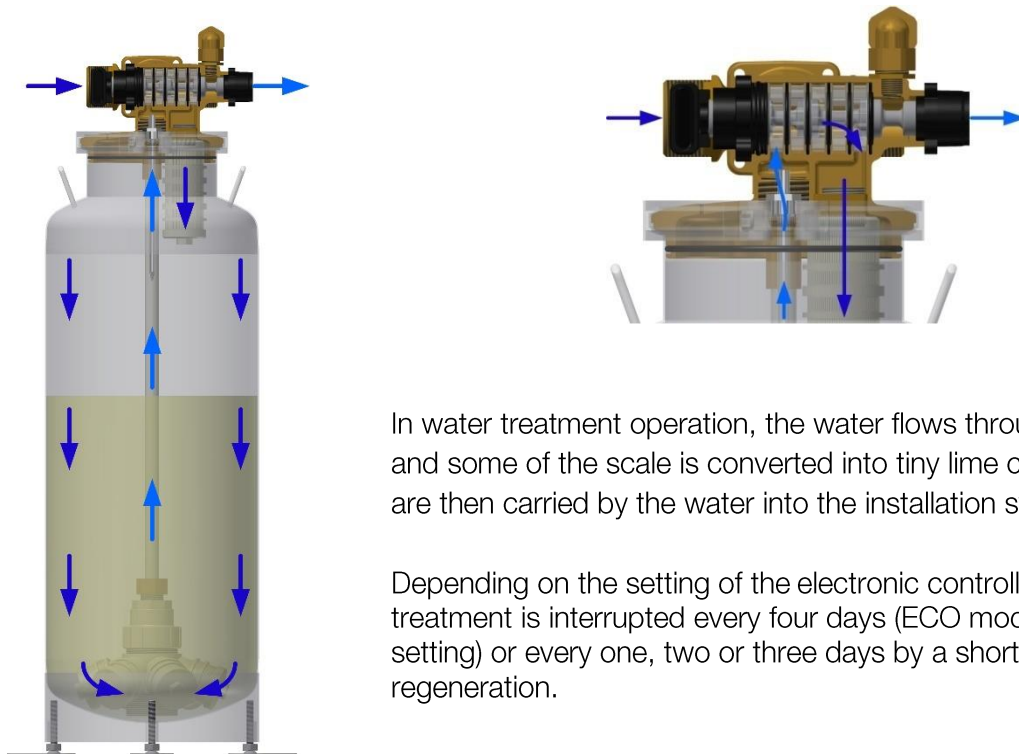

In water treatment operation, the water flows through the device and some of the scale is converted into tiny lime crystals, which are then carried by the water into the installation system.

Depending on the setting of the electronic controller, the water treatment is interrupted every four days (ECO mode; factory setting) or every one, two or three days by a short thermal regeneration.



Operating display:

Status: 01

Green LED: lights up

7.3 Thermal disinfection (TD)

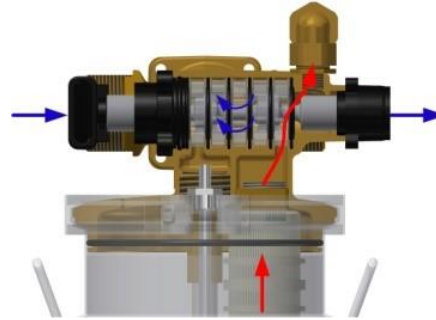
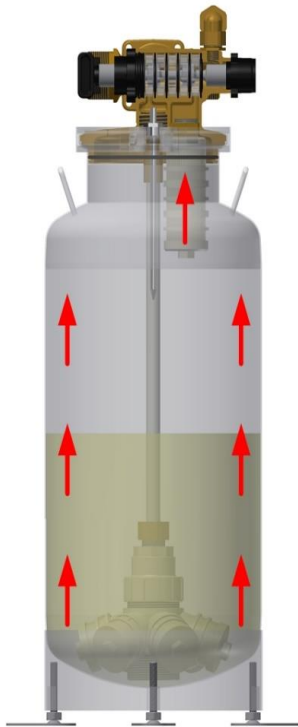

The first automatic TD is always run at 0:00 following commissioning or a power interruption. After this first TD, the next are run, depending on the settings, at regular four-day intervals in eco mode or every 1, 2 or 3 days.

The Multi-chamber valve separates the tank from the cold-water supply. During the heating process, the tank is unpressurised. The water enters via the bypass position of the Multi-chamber valve.

A filament heats the water in the tank for approx. 70 minutes to 80 °C and maintains the temperature for another approx. 90 minutes, thus ensuring uniform heating of the tank contents.



Operating display:

Status: 02

Green LED: lights up

7.3.1 Setting the thermal disinfection (TD) interval

During the initial start-up, commissioning must be started manually. The device automatically fills up with water:

1. Press and hold the  „M“-button for more than 7 seconds.

The display automatically switches to ‘d.1.’ or ‘d.2.’ or ‘d.3.’

Display: d._.

The second digit of the display flashes

2. By pressing the ‘+’ button, you can alter the interval of the thermal disinfection.
Example:

d.3. means: thermal disinfection is carried out every four days

d.1. means: thermal disinfection is carried out each day

Factory setting: d.3. (every four days)

3. Press the “M” button to accept the set value.
The current status number appears on the display once again.

Display: 01-05

LED: green

7.3.2 Manually activating thermal disinfection

Press and hold the  ‘M’ button for approx. two seconds.
(count: twenty-one, twenty-two)

The control system starts automatically with a commissioning routine.

Display: 04. / 02.

The decimal point on the display will flash until the valve spool has reached the secure TD position.

LED: green

NOTE:

- DO NOT leave the limescale conditioning system unattended while the decimal point is flashing
- DO NOT unplug the limescale conditioning system while the decimal point is flashing



After longer operational interruptions, a thermal disinfection must be activated manually as part of the commissioning.

7.4 Backflushing

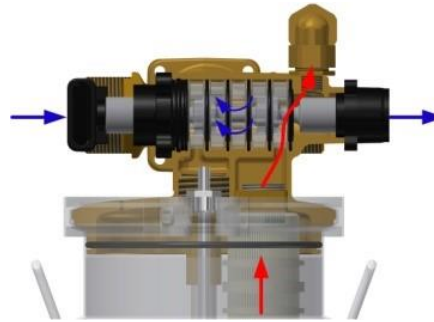
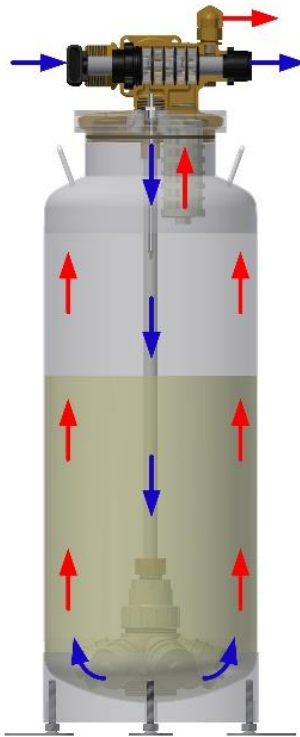

After the TD, hot water is flushed from the cartridge through the rinsing line. The Multi-chamber valve moves into the backflush position. Cold water flows into the cartridge and displaces the hot water, flowing through the rinsing pipe into the drain.

Once the cartridge is cooled, backflushing is terminated, and the unit reverts to normal operation.

In the event of a power failure during backwash operation, the flush flow is automatically interrupted by the integrated fail-safe function.



Operating display:

Status: 03

Green LED: lights up



Danger of scalding!

During backflushing, hot water (80 °C) comes out from the backflushing pipe following thermal regeneration!

7.5 Self-test

While the decimal point is flashing, the device is automatically filling up with water, and all the important functions are being checked:

1. Multi-chamber valve drive
2. Position indicator
3. The slider is moved into the backflushing position,
→ the device is automatically aerated
4. Heating element for thermal disinfection
5. **Check the dimensioning of the drain!**
Flushing is repeated several times



ACTIVE ●
CAT ○
ERROR ○

After the self-test, a TD is automatically started.
Status no.: 02. / thermal disinfection

NOTE:

Please DO NOT leave the limescale conditioning system unattended, and DO NOT unplug it as long as the decimal point is flashing!

7.6 Battery test

Battery test expires after the following points:

- at each insertion, after commissioning
 - after every 10 thermal disinfections
1. Discharge of the battery for about three minutes (corresponds to one revolution of the motor)
 2. Checking of the battery voltage during discharge.
 3. At a battery voltage of <3 V, the battery is recharged for 22 hours and tested again.
 - a. Battery voltage >3 V → 25 minutes of recharging
 - b. Battery voltage <3 V → defective battery / output error 80-82
 - c. Transition to WT or to the self-test (unless this was skipped during commissioning)



ACTIVE ●
CAT ○
ERROR ○

Operating display:
Status: 05
Green LED: lights up

7.7 Error messages / malfunctions



An error or a problem exists only if the red LED is continuously lit up. The error code is given on the display.
If the red LED is not lit up, the display indicates the current operating condition.
If the yellow LED lights up, a catalyst granulate change/cartridge replacement is necessary.

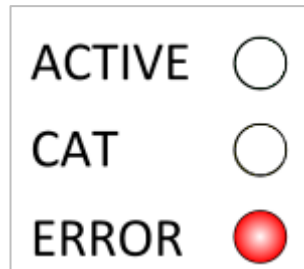

In the event of an operational malfunction, an audible alarm is sounded, and the red LED (ERROR) lights up. The BCT contact (signal contact) is opened (signal = 0).

The audible alarm can be acknowledged by pressing and holding the M button for three seconds.



Errors can be reset by unplugging and plugging in again.
Should an error persist, it will be displayed again during commissioning (→ see Commissioning).

If the self-test (04) returns an error, an attempt can be made to fix it based on the troubleshooting guide or by contacting factory customer service.

Please be sure to include the unit's serial number when notifying factory customer service.



Malfunction messages		
20	RTC (real-time clock) defective/communications with RTC not possible	Unplug and re-insert the plug, begin commissioning (see Commissioning Instructions) If the error recurs → inform factory customer service

30	WT POS not reached	Unplug and re-insert the plug, begin commissioning (see Commissioning Instructions) If the error recurs → inform factory customer service
31	TD POS not reached	
32	RS POS not reached	
33	TD POS not reached via timing control. Fail-safe not possible!	
34	TD POS not reached in fail-safe mode. Fail-safe not possible!	
35	Position switch 1 defective	
36	Position switch 2 defective	

40	Not in TD POS when heating switched on! Heating is not possible.	Review: Heater not correctly connected: → Plug in the heater STL triggered (check water supply → reset STL [Safety Temperature Limiter]) Unplug and re-insert the plug, begin commissioning (see Commissioning Instructions) If the error recurs or is not listed above → inform factory customer service.	
41	Heating current not in the specified range / no heating current/heater unplugged / STL activated, line interrupted / heater defective		
42	Impermissible heating current while heater is switched off!		
43	Heating relay defective! One relay contact is frozen		
44	Heating current disconnected / STL activated / line disrupted / heater defective		

Position of STL on back of the BIOCAT.

60	Temperature sensor defective / not connected / unrealistic measured temperature value	Inform factory customer service.
61	TD error: heat-up temperature not achieved	
62	TD error: maintenance temperature not reached	
63	RS error: cold-water temperature not achieved	Check water supply. Unplug and re-insert the plug, begin commissioning If the error recurs → inform factory customer service.

80	Battery defective! Battery voltage less than 3 V	Inform factory customer service.
81	No battery present.	
82	Battery voltage is less than 3 V in fail-safe mode. Fail-safe is not possible!	

7.8 Service

The yellow LED blinking indicates the upcoming change of the cartridge in the following combinations:

during operation: *in the event of an* Operating display:
Status 01-05 *error:*

Status 20-82 **Yellow LED flashes (SERVICE)**



Green LED error-free operation.
(Status 01-05)

Red LED fault present.
(Status 20-82)



Audible alarm from 07:00 to 22:00 (device does not change to daylight saving time! -> in the summer from 08:00 - 23:00)

8 Maintenance



Before carrying out maintenance or repair work, block access to the working area of the limescale protection device for unauthorised persons!

- Attach or erect a sign indicating that maintenance or repair work is being carried out.
- Unplug the device, depressurise the system and secure it against being switched on again.
- Before maintenance and repair work, ensure that all device and system parts have cooled down to room temperature.

Component	Exchange interval
Active unit	5 Years *1)
Multi-chamber valve	5 Years *2)
Seals and RV valve	10 Years *2)

*1): The lime protection unit must be renewed at intervals of 5 years, regardless of the water consumption. If the water is permanently treated chemically (e. g. B chlorinated) reduces the lifespan of the lime protection unit to 3 years.

*2): The multi-chamber valve must be replaced after 5 years, all other wearing parts such as valves and seals must be replaced after 10 years.

We recommend an annual inspection by a certified specialist.



Danger of scalding!

During thermal disinfection (TD) and subsequent backwashing (RS), there is hot water (80 °C) in the limescale protection unit of the BIOCAT.

It is essential to cool down the BIOCAT before starting maintenance work - or wait for TD and RS until the BIOCAT is in the operating mode water treatment (WT)!



Do not clean plastic parts and sealing elements with solvents!

The manufacturer accepts no liability for damage caused by failure to comply with these operating instructions, the applicable regulations or improper use. The risk is borne solely by the operator.



Service

When requesting service, please be sure to quote the BIOCAT serial number from the type plate and the error code from the device display!



WATERCryst Wassertechnik GmbH
Elsa-Brandström-Str. 31
DE-42781 Haan
+49 2129 3475 - 204

Branch Austria
Messerschmittweg 26
AT-6175 Kematen in Tirol
+43 5232 20602 - 204
office@watercryst.com, www.watercryst.com



WATERCryst in Denmark
WATERCryst Vandteknik ApS
Birk Centerpark 40 - C/O Innovatorium A/S
DK-7400 Herning
+45 89 88 07 63
denmark@watercryst.com, www.watercryst.dk



WATERCryst partner in Czechia and Slovakia
Duco Tech CZ s.r.o.
Polívkova 583/30
CZ-158 00 Praha 5 - Jinonice
+420 777 733 095
servis@ducotech.cz, www.ducotech.cz



WATERCryst partner in Switzerland
Georg Fischer JRG AG
Hauptstraße 130
CH-4450 Sissach
+41 61 975 23 77
tkd.jrg.ps@georgfischer.com, www.gfps.com

This document is translated from German

Technical changes, typesetting and printing errors reserved

Ident. Nr. 11013865_v3 / 02.25 / ©Georg Fischer JRG AG

BFS Code 1161579_v3_02_2025
Production: GF BFS / SDE