

# JRG

# +GF+

Montageanleitung  
Notice de montage  
Istruzioni per il montaggio  
Installation instructions  
Instrucciones de instalación

## JRGURED Combi

Hauswasserstation	DE	2 – 5
Station de réduction avec filtre	FR	7 – 10
Gruppo acqua combinato	IT	11 – 14
Domestic water station	EN	15 – 18
Estación de agua doméstica	ES	19 – 22

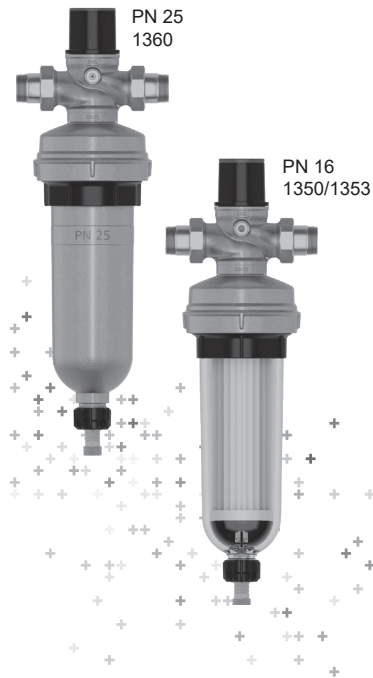

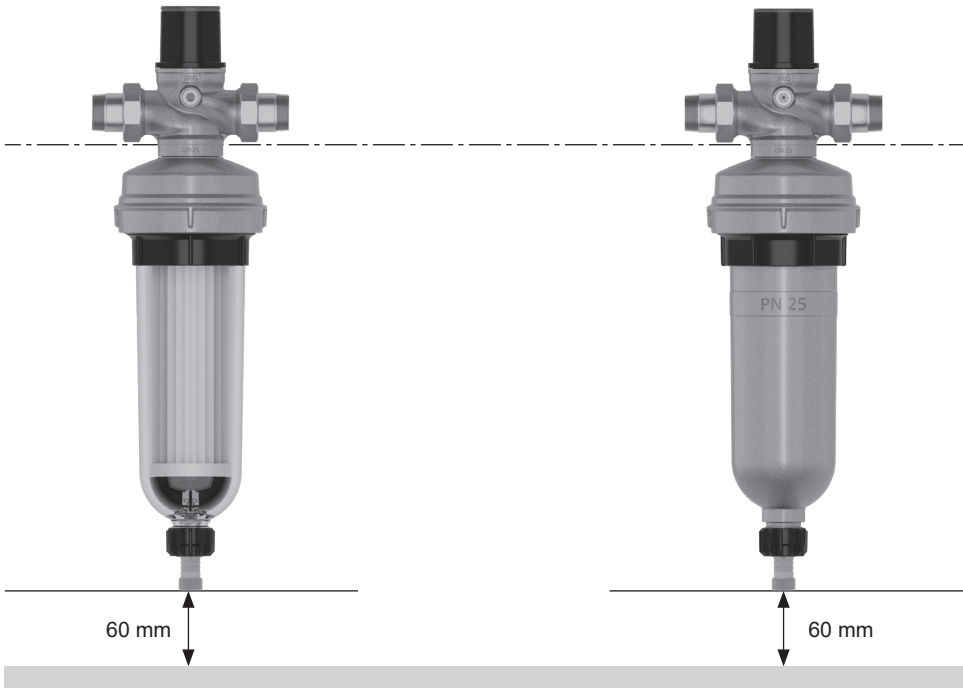

## Montageanleitung

Bitte lesen Sie die vorliegende Montageanleitung aufmerksam durch. Die eingesetzten Symbole bedeuten:



### Warnung

Dieses Symbol weist auf eine Information hin, deren Nichtbeachtung zu umfangreichen Sachschäden führen kann. Die Sicherheitshinweise sind zu beachten.



### Hinweis

Dieses Symbol weist auf eine Information hin, die wichtige Angaben hinsichtlich der Verwendung enthält. Das Nichtbefolgen kann zu Störungen führen.

## Allgemeines

Die Hauswasserstation **JRGURED Combi** ist eine kompakte Armaturenkombination für Wasserinstallationen\*, bestehend aus Feinfilter und Druckreduzierventil.

\* Andere Anwendungen auf Anfrage.

Der vor dem Druckreduzierventil eingesetzte Filtereinsatz dient lediglich dem Zurückhalten von eingespülten Schwebstoffen. Er ersetzt in keiner Weise eine gewünschte oder notwendige Wasseraufbereitung (Enthärtung, Entkeimung, etc.)!

## Einsatzbereich

Die Hauswasserstation **JRGURED Combi** ist für folgende Einsatzbereiche zugelassen:

JRG Code	PN kPa / bar	$p_{sec}^*$ kPa / bar	$t_{max}$ °C
1350 / 1353	1'600 / 16	200-600 / 2-6	30
1360	2'500 / 25	200-600 / 2-6	30**

\* Andere Einstelldrücke auf Anfrage

\*\* Bei JRG Code 1360 mit Filtereinsatz  
JRG Code 1839 bis 70°C

### Kennzeichnung

- 1-2 (GN/Ventilgrösse)
- JRG (Herstellerzeichen)
- Durchflusspfeile



AFM 34 Dichtungen dürfen nicht geölt oder gefettet werden!

### Werkseinstellung

Die Hauswasserstation **JRGURED Combi** ist werkseitig auf einen Sekundärdruck von 400 kPa / 4 bar eingestellt. Andere Einstelldrücke auf Anfrage.

### Installationsvorschriften



Beim Einbau der JRG Hauswasserstation **JRGURED Combi** sind die örtlich geltenden Vorschriften/ Normen einzuhalten.

### Montage



Die Hauswasserstation **JRGURED Combi** darf nur mit geeignetem Werkzeug montiert werden.

### Einbaulage



Die Hauswasserstation **JRGURED Combi** ist an einer gut zugänglichen Stelle, spannungsfrei in eine horizontale Leitung einzubauen.

Für die Filterwartung ist unter dem Entleerventil ein Mindestabstand von 60 mm einzuhalten (Abbildung Seite 2). Wird für die Entleerung ein Schlauch eingesetzt, ist dieses Mass entsprechend zu berücksichtigen.



Hauswasserstationen mit Klarsichtfilterbecher sind so zu montieren, dass sie vor intensiver UV-Strahlung geschützt sind. Bei Installationen in aggressiver Umgebung und/oder in Räumen mit unkontrollierbaren Umwelteinflüssen (wie Lösungs- oder Reinigungsmitteldämpfen etc.) muss der Klarsichtfilterbecher entsprechend geschützt oder gegen einen Rotgussfilterbecher ersetzt werden. Im Zweifelsfall beraten wir Sie gerne.

### Inbetriebnahme



Vor der Inbetriebnahme der Hauswasserstation **JRGURED Combi** ist die Zuleitung gründlich zu spülen. Für die Inbetriebnahme ist die separate Bedienungs- und Wartungsanleitung zu beachten.



An der Hauswasserstation **JRGURED Combi** dürfen keine Reparaturen vorgenommen werden.

### Umstellung des Druckreduzierventils



Ein Umstellen der Werkseinstellung erfolgt ausschliesslich auf Verantwortung des Ausführenden. Für das Umstellen beachten Sie bitte die separate Bedienungs- und Wartungsanleitung.

### Wartung



Für die Wartung des Feinfilters ist die separate Bedienungs- und Wartungsanleitung zu beachten. Diese ist bei der Übergabe der Anlage dem Hauseigentümer bzw. Anlagebetreiber abzugeben.





## Notice de montage

Veuillez lire attentivement la présente notice de montage. Voici la signification des symboles utilisés:



### Avertissement

Ce symbole rappelle une information dont le non-respect peut entraîner des dommages considérables. Suivre les consignes de sécurité.



### Remarque

Ce symbole signale une information qui comprend des indications importantes portant sur l'utilisation. Le non-respect peut se traduire par des pannes.

## Généralités

La station **JRGURED Combi** constitue une combinaison compacte de robinetterie, destinée aux installations de distribution d'eau\*. Elle se compose d'un filtre fin et d'un réducteur de pression.

\* Autres applications sur demande.

Le cartouche filtrante montée dans la station **JRGURED Combi** sert uniquement à retenir les particules en suspension. Elle ne remplace en aucun cas une installation souhaitée ou indispensable de traitement de l'eau (déméralisation, décontamination, etc.)!

## Domaine d'utilisation

La station **JRGURED Combi** est homologuée pour les domaines d'utilisation suivants:

JRG Code	PN kPa / bar	$p_{sec}^*$ kPa / bar	$t_{max}$ °C
1350 / 1353	1'600 / 16	200-600 / 2-6	30
1360	2'500 / 25	200-600 / 2-6	30**

\* Autres valeurs de consigne sur demande

\*\* JRG Code 1360 avec cartouche filtrante JRG Code 1839 jusqu'à 70°C

### Repérage

- 1, 1¼, 1½, 2 (GN/grandeur de vanne)
- JRG (nom du fabricant)
- Flèches de débit



Ne jamais graisser ni huiler les joints plats en fibrine AFM 34.

### Pression de consigne

Départ usines, la pression secondaire des stations **JRGURED Combi** est ajustée sur 400 kPa (4 bars).

### Prescription de pose



Lors du montage de la station **JRGURED Combi**, les prescriptions ainsi que les normes de montage locale sont à respecter.

### Montage



La station **JRGURED Combi** ne doit être montée qu'avec l'outillage approprié.

### Position de montage



La station **JRGURED Combi** ne doit être montée que dans des conduites horizontales, en un endroit facilement accessible. Pour assurer l'entretien du filtre fin, il convient de ménager une distance minimale de 60 mm sous le robinet de vidange (illustration page 2). Lorsque la vidange s'effectue au moyen d'un tuyau, il convient d'augmenter la distance ci-dessus.



Les stations **JRGURED Combi**, équipées d'une cuve transparente ne doivent pas être exposées au rayonnement ultraviolet intense. Sur des installations dans un entourage agressif et/ou à des endroits avec des influences ambiantes non contrôlables (comme des vapeurs de dissolvant ou de produits de nettoyage etc.) la cuve transparente doit être protégée contre l'environnement, ou échangée contre une cuve en fonte rouge. Nous vous conseillons volontiers en cas d'incertitude.

### Mise en service



Avant la mise en service de la station **JRGURED Combi**, il convient de rincer soigneusement la conduite. Pour la mise en service, il convient de respecter les instructions d'utilisation et de maintenance séparées.



Il n'est pas permis d'entreprendre des réparations aux stations **JRGURED Combi**.

### Modification de la valeur de consigne du réducteur de pression



Une modification de la valeur réglée en usine se fait sous l'entière responsabilité de l'exécutant. Pour modifier la valeur de consigne, veuillez s.v.p. observer les indications de la notice d'utilisation et d'entretien séparée.

### Entretien



L'entretien du filtre fin s'effectue en suivant les indications de la notice séparée d'utilisation et d'entretien. Cette notice sera donnée au propriétaire ou l'exploitant de l'installation lors de la remise de l'installation.

# JRG

Istruzioni per il montaggio

# +GF+

## JRGURED Combi

Gruppo acqua combinato

IT 11-14

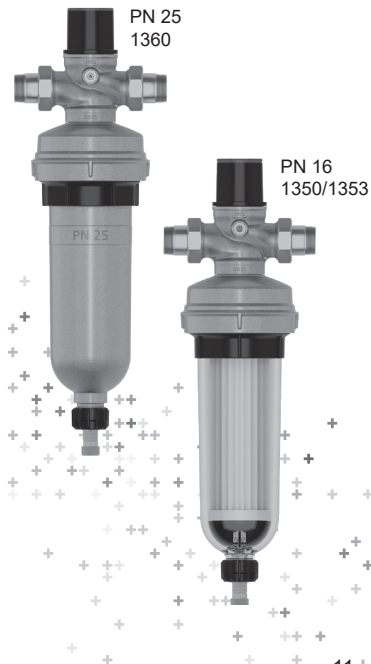

## Istruzioni per il montaggio

Leggere attentamente le seguenti istruzioni per il montaggio.

Significato dei simboli:



### Attenzione

Questo simbolo indica un'informazione il cui mancato rispetto potrebbe causare dei danni materiali consistenti. Osservare attentamente le informazioni sulla sicurezza.



### Avvertenza

Questo simbolo fornisce importanti indicazioni concernenti l'utilizzo. Il loro mancato rispetto potrebbe causare dei guasti..

## Generalità

Il gruppo acqua combinato **JRGURED Combi** è un raccordo multiplo per installazioni idrauliche\*, composto da un filtro a maglia fine e da un riduttore di pressione.

che\*, composto da un filtro a maglia fine e da un riduttore di pressione.

\* Altre applicazioni su richiesta.

Il parte filtrante impiegata nel **JRGURED Combi** serve soltanto a trattenere l'affluire di sostanze galleggianti. Non rimpiazza in nessun caso un trattamento d'acqua desiderato o necessario (decalcificazione, disinfezione, ecc.).

## Campo d'impiego

Il gruppo acqua combinato **JRGURED Combi** è omologato per i seguenti campi d'impiego:

JRG Code	PN kPa / bar	$p_{sec}^*$ kPa / bar	$t_{max}^{\circ C}$
1350 / 1353	1'600 / 16	200-600 / 2-6	30
1360	2'500 / 25	200-600 / 2-6	30**

\* Altre regolazioni di pressione su richiesta

\*\* JRG Code 1360 con parte filtrante  
JRG Code 1839 fino 70°C

### Identificativo

- 1, 1¼, 1½, 2 (GN/Misura della valvola)
- JRG (marchio di fabbricazione)
- Frecce di indicazione del flusso



Le guarnizioni AFM 34 non devono essere né oliate né ingrassate.

### Regolazione da fabbrica

Il gruppo acqua combinato **JRGURED Combi** è regolato da fabbrica ad una pressione secondaria di 400 kPa (4 bar).

### Istruzioni per il montaggio



Per il montaggio del gruppo acqua combinato **JRGURED Combi**, bisogna attenersi alle direttive e alle prescrizioni locali.

### Montaggio



L' **JRGURED Combi** deve essere montato solo con attrezzi idonei.

### Posizione di montaggio



Il gruppo acqua combinato deve essere montato solo su condotte orizzontali e facilmente accessibile.

Per la manutenzione del filtro bisogna osservare una distanza minima di 60 mm sotto il rubinetto di scarico (illustrazione a pagina 2). Se per lo scarico si impiega un questa distanza deve essere aumentata di conseguenza.



I gruppi acqua combinati **JRGURED Combi** con tazza trasparente devono essere montati protetti dai raggi ultravioletti. Installazioni in un ambiente aggressivo e/o in locali con influssi ambientali non controllabili (come solventi o vapori di detersivi ecc.) la tazza del filtro deve essere protetta o sostituita con una tazza in bronzo. In caso di dubbi siamo a vostra disposizione per consigli in merito.

### Messa in funzione



Prima della posa in opera di **JRGURED Combi** bisogna pulire le tubazioni in modo da eliminare ogni residuo. Per la messa in funzione, è necessario osservare le istruzioni per l'uso e la manutenzione separate.



Il gruppo acqua combinato **JRGURED Combi non** deve essere sottoposto a nessuna riparazione.

### Modifica delle regolazioni



La modifica delle regolazioni avviene sotto la responsabilità esclusiva di chi le effettua. Per procedere alle modifiche, attenersi alle istruzioni per l'uso e la manutenzione separate.

### Manutenzione



Per la manutenzione del filtro a maglia fine bisogna osservare le avvertenze d'uso e di manutenzione specifiche. Queste devono essere fornite al proprietario o al gestore dell'impianto dello stabile al momento della consegna dell'impianto.

# JRG

Installation instructions

# +GF+

## JRGURED Combi

Domestic water station

E 15–18

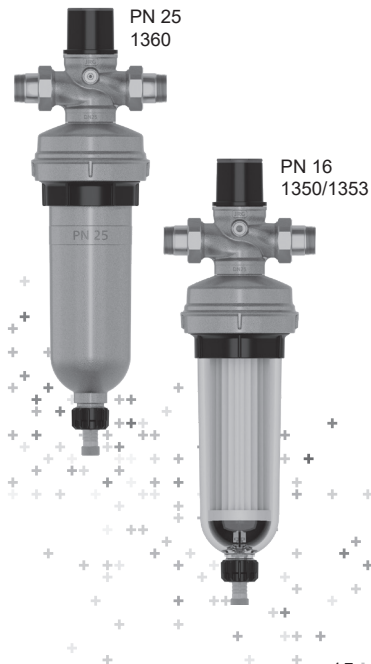

## Installation instructions

Please read carefully the installation instructions. The used symbols mean:



### Warning

This symbol point out a information, ignoring of it can cause extensive material damage. The security information has to be observed.



### Note

This symbol point out a information, which indicate important details concerning the use. Ignoring of it can result in trouble.

## General

The **JRGURED Combi** domestic water station is a multiple fitting for water systems\*, consisting of a fine filter and a pressure reducing valve.

\* Other applications on request.

The filter element employed in the **JRGURED Combi** is only for retaining ingested suspended particles. It in no way replaces any desired or necessary water treatment (softening, sterilization, etc.).

## Operating range

The **JRGURED Combi** domestic water station is authorized for the following operating ranges:

JRG Code	PN kPa / bar	$p_{sec}^*$ kPa / bar	$t_{max}$ °C
1350 / 1353	1'600 / 16	200-600 / 2-6	30
1360	2'500 / 25	200-600 / 2-6	30**

\* Other pressure settings to order

\*\* JRG Code 1360 with filter element  
JRG Code 1839 to 70°C

### Identification

- 1, 1¼, 1½, 2 (DN/valve size)
- JRG (manufacturer)
- Flow direction arrow



Seals made of **AFM 34** should **never** be used with grease or oil.  
(AFM = Asbestos Free Material).

### Factory setting

The **JRGURED Combi** domestic water station is factory set to a secondary pressure of 400 kPa (4 bar).

### Installation requirements



During the installation of the **JRGURED Combi**, domestic water station, relevant regulations of the local water supply utility must be observed.

### Installation



The **JRGURED Combi** domestic water station must be fitted only with suitable tools.

### Mounted position



The **JRGURED Combi** domestic water station must be mounted in a horizontal pipe, and easily accessible.

A minimum space of 60 mm must be allowed under the filter so that it can be dismantled for maintenance (figure page 2). If a hose is used for drainage, this distance must be increased accordingly.



**JRGURED Combi** domestic water stations with a clear plastic filter cup must not be exposed to continuous strong sunlight. If the filter is installed in an aggressive vicinity or in rooms with uncontrollable environment (solvents and/or cleaning agent vapors etc.) the transparent filter cup must be protected accordingly or replaced by a gunmetal filter cup. We will be pleased to advise you in cases of doubt.

### Commissioning



Before putting the **JRGURED Combi** domestic water station into operation, thoroughly flush the in feed pipe.

### Resetting the pressure reducing valve



Any change to the factory pressure setting is carried out exclusively on the responsibility of the person doing so. For resetting the pressure, please refer to the separate operating- and maintenance instructions.

### Maintenance



The fine filter must be maintained according to the separate operating and maintenance instructions. These are to be given to the building owner or plant operator when handing over the installation.



Repairs to the **JRGURED Combi** domestic water station must not be attempted.

# JRG

Instrucciones de instalación

# +GF+

## JRGURED Combi

Estación de agua doméstica ES 19 – 22

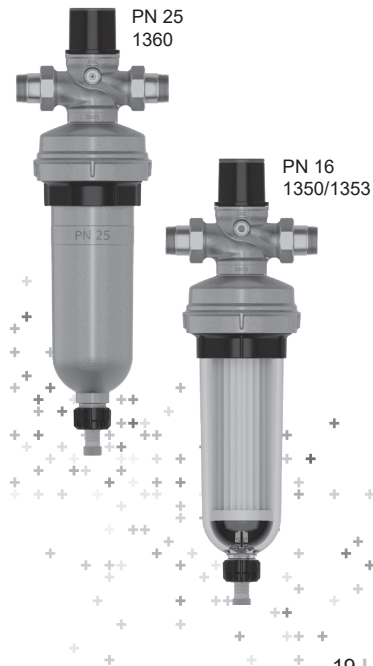

## Instrucciones de instalación

Lea detenidamente las instrucciones de instalación. Significado de los símbolos utilizados:



### Advertencia

Este símbolo indica información, ignorarlo puede dañar gravemente el material. Se debe cumplir la información de seguridad.



### Nota

Este símbolo indica información con datos importantes relacionados con el uso de la válvula. Ignorarlo puede derivar en un problema.

## Cuestiones generales

La válvula reductora de presión **JRGURED Combi** es un componente compacto para sistemas de agua\*, que consiste en un filtro de malla y en una válvula reductora de presión.

\* Otras aplicaciones bajo petición.

El elemento filtrante empleado en el JRGURED Combi sólo sirve para retener las partículas en suspensión. En ningún caso sustituye a los tratamientos deseado o necesario (descalcificación, esterilización, etc.).

## Rango de funcionamiento

La válvula reductora de presión **JRGURED** es compatible con los siguientes rangos de funcionamiento:

JRG Code	PN kPa / bar	$p_{sec}^*$ kPa / bar	$t_{max}^{\circ C}$
1350 / 1353	1'600 / 16	200-600 / 2-6	30
1360	2'500 / 25	200-600 / 2-6	30**

\* Otros ajustes de presión bajo pedido

\*\* JRG Code 1360 con elemento filtrante JRG Código 1839 a 70°C

### Identificación

- 1-2 (DN/tamaño de válvula)
- JRG (marca comercial del fabricante)
- Flechas de sentido de flujo



Las juntas de AFM 34 no pueden ser aceitadas o engrasadas.

### Ajuste de fábrica

La estación de agua sanitaria **JRGURED Combi** viene ajustada de fábrica a una presión secundaria de 400 kPa (4 bar).

### Requisitos previos a la instalación



Se aplica la normativa de servicio de agua local para la instalación de las válvulas reductoras de presión **JRGURED Combi**.

### Instalación



La válvula reductora de presión **JRGURED Combi** solo debe instalarse aplicando las posiciones adecuadas.

### Posición de instalación



Debe instalarse en un lugar de la tubería fácilmente accesible.

Para el mantenimiento del filtro puede dejar una pequeña holgura de 60 mm (ilustración página 2). Si se utiliza una manguera para el vaciado, deberá tenerse en cuenta esta dimensión.



Las estaciones de agua sanitaria con vasos filtrantes transparentes deben instalarse de forma que estén protegidas de la radiación UV intensa. Para instalaciones en entornos agresivos y/o en salas con influencias ambientales incontrolables (como vapores de disolventes o productos de limpieza, etc.), la copa de filtro transparente debe protegerse adecuadamente o sustituirse por una copa de filtro de fundición. En caso de duda, estaremos encantados de asesorarle.

### Puesta en marcha



Antes de poner en marcha el JRGURED Combi, la tubería de entrada tiene que estar completamente purgada.

Para la puesta en marcha, diríjase a las instrucciones de mantenimiento y funcionamiento individuales.

### Reajustar la válvula reductora de presión



La responsabilidad de llevar a cabo cualquier modificación en los ajustes de presión de fábrica recaerá exclusivamente en la persona que los realice. Para reajustar la presión, diríjase a las instrucciones de mantenimiento y funcionamiento individuales.

### Mantenimiento



Para el mantenimiento del filtro fino diríjase a las instrucciones de mantenimiento y funcionamiento

individuales. Estas se deben entregar al dueño del edificio u operador de planta cuando se vaya a llevar a cabo la instalación.



No intente reparar la válvula reductora de presión **JRGURED Combi**.



## **Georg Fischer JRG AG**

Hauptstrasse 130, CH-4450 Sissach

Phone +41 (0)61 975 22 22, Fax +41 (0)61 975 22 00

[www.jrg.ch](http://www.jrg.ch), [info.jrg.ps@georgfischer.com](mailto:info.jrg.ps@georgfischer.com)

**[www.gfps.com](http://www.gfps.com)**

Ident. Nr. 350 945 919 / ©Georg Fischer JRG AG

BFS Code 1161451\_v3\_09\_2025

Production: GF BFS / SDE

# **JRG**

# **+GF+**