

JRG

+GF+

JRG Valves

JRGUMAT

Thermostatic Mixing Valve



JRGUMAT – Mixed water temperature without auxiliary energy

The proven JRGUMAT thermoblen­ding valves are thermostatically regulating mixing valves, which are used everywhere where a constant mixed water temperature of high control accuracy is desired or required.

+ Properties

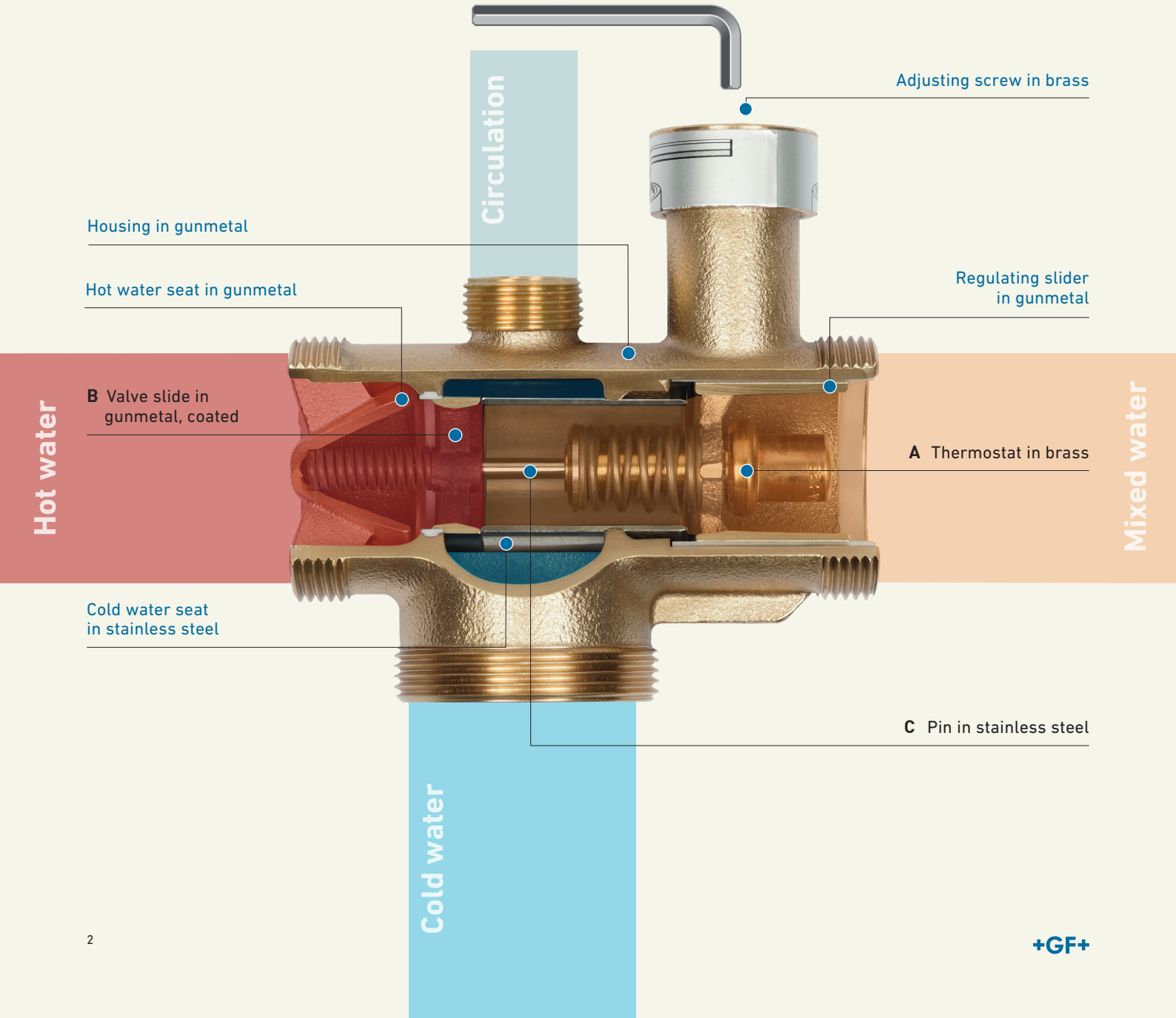

The JRGUMAT thermostatic mixing valve is a three-way valve made of gunmetal, which proportionally regulates the mixed water temperature without the need for auxiliary energy.

The mixed water temperature is transferred to thermostat **A**, which compares it with the set target value. If the water temperature does not match the target value, a volume change is triggered in thermostat **A**. Valve slide **B** is now moved by pin **C** until the temperature of the mixed water matches the target value. The JRGUMAT valve is also used as a thermal switch.

For safe operation and maintenance, the valves as shown in the installation examples below are required.

Fields of Application

The well-proven JRGUMAT thermostatic mixing valves are thermostatically controlled mixing valves which are used whenever a constant mixed water temperature and high control accuracy are desired or required, e.g. as central mixing valve in detached houses and apartment buildings, hospitals, nursing homes, hotels, barracks, shower rooms of sports facilities, industrial and commercial buildings.

JRGUMAT thermostatic mixing valves also serve as excess temperature protection in systems using alternative forms of energy such as solar systems, firewood heating, wood chip furnaces, pellet heating, etc. Thanks to their high control accuracy, JRGUMAT thermostatic mixing valves can also be used for special applications, e.g. as controller for high-temperature maintenance.

Hot water temperature

To ensure proper function of the JRGUMAT thermostatic mixing valve, the hot water temperature should be at least 5K higher than the desired mixed water temperature. Furthermore, identical hydraulic conditions at the hot and cold water inlets are crucial for the mixing valve to function properly. This is ensured by installing the mixing valve in the water heater circuit in accordance with our installation examples.

+ Advantages

- Delivers mixed water at constant temperature
- High control accuracy
- Operates without auxiliary energy
- Protects from scalding
- Saves energy
- Increases comfort and safety in the hot water system

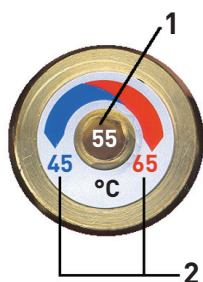

1 Factory settings Default temperature °C	2 Mixed water Adjustment ranges °C	Adjustment of the mixed water temperature per full turn of the key		
		GN ½ -1 DN 15-25	GN 1¼ -2 DN 32-50	DN 65/80
25	20-30			
40	30-45			
55	45-65	ca. 6 K	ca. 4 K	ca. 2 K
70*	60-80			

* only available as type 3400

Nomogram for JRGUMAT thermostatic mixing valves 3400 and 3410

The determined pipe dimension is also considered nominal width DN for the JRGUMAT thermostatic mixing valve. Relations of volume flow, nominal width and pressure drop may also be determined with the help of this nomogram. The greyshaded area provides optimal operating conditions.

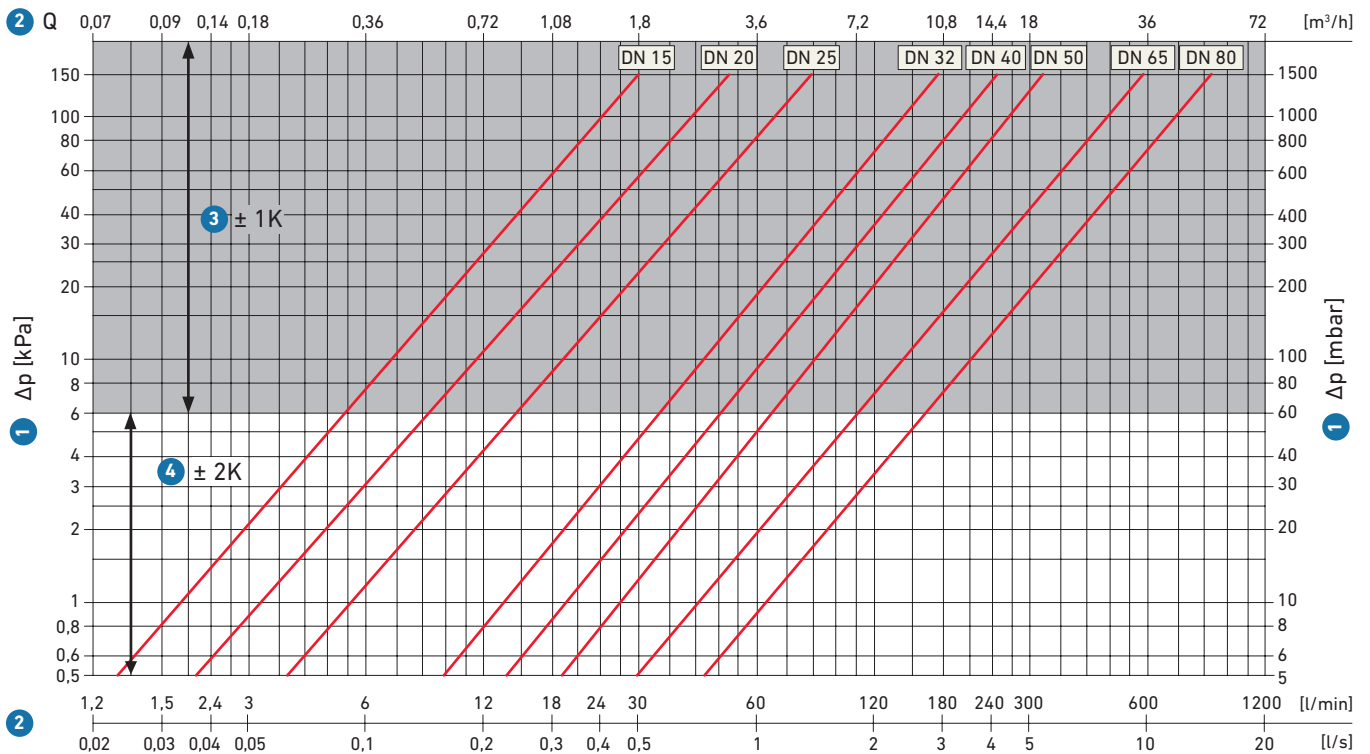

- ① Pressure drop
- ② Flow rate
- ③ Setpoint tolerance $\pm 1\text{K}$
- ④ Setpoint tolerance $\pm 2\text{K}$

Noise behaviour

Dimensions	GN ½	DN 15	GN ¾-1¼	DN 20-32
Valve group	I		II	

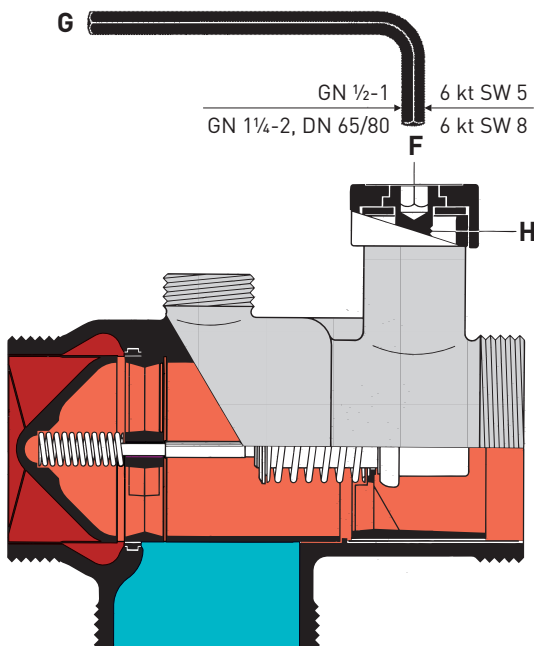

Factory settings/Adjustment

JRGUMAT thermostatic mixing valves come with a thermostat whose temperature is factory-set at a default value which can be taken from the temperature plate **F** on the valve and on the packaging. This default temperature may only be changed within the limits of the assigned temperature range.

The procedure is as follows:

Use the Allen key **G** to pierce the temperature plate **F** in the middle. Turn the screw **H** clockwise to increase and counter-clockwise to decrease the temperature of the mixed water. The volume flow must be within the greyshaded area "Setpoint tolerance $\pm 1\text{K}$ " (see nomogram).



Installation Instructions/ Maintenance/Transport Packaging

Installation instructions

Follow the installation examples and observe local standards and guidelines when installing your JRGUMAT valve. The JRGUMAT thermostatic mixing valve can be mounted in any position.

Install only valves (Y-valves, back flow preventers, etc.) with low pressure drop. Thoroughly flush the supply line before installing the JRGUMAT thermostatic mixing valve.

To prevent the mixing valve from malfunctioning, install it side by side with the heater and provide it with a 15 cm high thermosiphon. The unions listed on page 11 are obligatory. Do not use unions sealing in the thread (e.g. hemp). AFM 34 gaskets must not be oiled or greased.

Back flow prevention

Install only low pressure drop check valves 1610 to 1615 and 1650, swing check valve 1682 and lockable back flow preventers 5262 to 5284.

Soldered union

During soldering, the solder-joint unions must be separated from the mixing valve, as the thermostat and the gaskets may otherwise be damaged.

Maintenance

- JRGUMAT thermostatic mixing valves are virtually maintenance-free.
- The installation and operating instructions are to be handed over to the building owner or plant operator on delivery.
- In case of trouble please check your installation with the help of the installation diagrams in this brochure.
- Replace the mixing valve in case of malfunctions due to clogging or calcification of the valve.

Transport packaging

After installing and adjusting the valve, the transport packaging of the JRGUMAT thermostatic mixing valve is used as thermal insulation and can be delivered as spare parts.

- Thermal conductivity $\lambda_D = 0.033 \text{ W/mK}$
- Fire behaviour (BKZ) 5.1/B1
- Application temperature $\leq 90^\circ\text{C}$

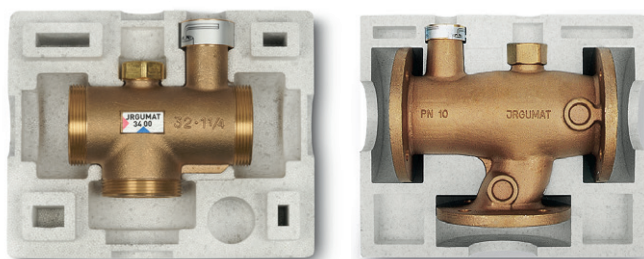

Overview of circulation valves used in building services

Static Circulation Valves



6310
Regulation socket

Dynamic Circulation Valves



6320 JRGUTHERM
Thermostatic circulation valves



6335
Needle valve































6325 JRGUTHERM 2T
Double thermostatic circulation valve for regulated normal and disinfection operation



Hycleen Automation System
9900 Hycleen Automation Master
9910 JRG LegioTherm 2T
Circulation controller for automatic, logged hydraulic balancing and thermal disinfection

Installation Examples with JRGUMAT Thermostatic Mixing Valves

Legend

JRG Code		Text	EN 806-1
-		PWC potable water, cold	
-		PWH potable water, hot	
-		PWH-C potable water, hot, circulation	
-		PWH-M potable water, hot, mixed water	
3400/3410		JRGUMAT thermostatic mixing valve	
1300-1310		Pressure reducing valve	
1350-1360		Pressure reducing valve with filter	
5200-5234		Shut-off valve	
1610-1615		Back flow preventer (controllable)	
5262-5284		Shut-off valve with integrated back flow preventer (controllable)	
1025/1028		Spring loaded safety valve	
6310-6325		Circulation valve	
-		Liquid pump with mechanical drive	
6000-6013		Ball valve	
1812		Mechanical filter	
-		Driven by electric motor	
-		Driven by electric solenoid (currentless open)	
-		Timer	
-		Regulated speed	

Notes

- 1-8** The installation examples are recommendations; we do not assume any responsibility for their completeness. Adhere to local standards and guidelines when installing safety devices, equipment and valves. These installation examples serve as guidelines only and should not be relied upon as a substitute for professional advice.
- 2-5+7** Flow path A = to avoid overheating, regulation socket 6310
Flow path B = to cover the heat loss, JRGUTHERM 6320
- 5** Thermal and proportional distribution of the flow rates. Control of the flow rates for the flow paths A and B with JRGUMAT. Size of the circulation valve as a function of circulation losses.
- 6+7** To ensure thermal disinfection, each tapping point must be flushed.
For thermal disinfection sufficient hot water must be available.
Please note: Scalding hazard during thermal disinfection. Thermal disinfection is possible only with a JRGUTHERM 2T circulation valve or with the Master Hycleen Automation JRG LegioTherm 2T.

Installation Examples with JRGUMAT Thermostatic Mixing Valves

1

Observe legend/notes!

Mixed water installation with circulation

*option

Option: Hot water outlet

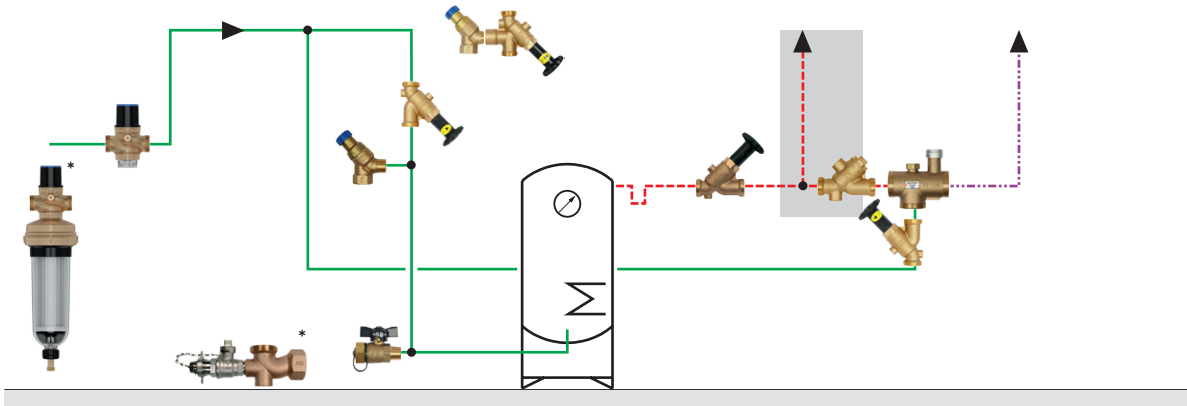

2

Observe legend/notes!

Mixed water installation with circulation
(Flow path A via cold water inlet of the mixing valve)

*option

Option: Hot water outlet

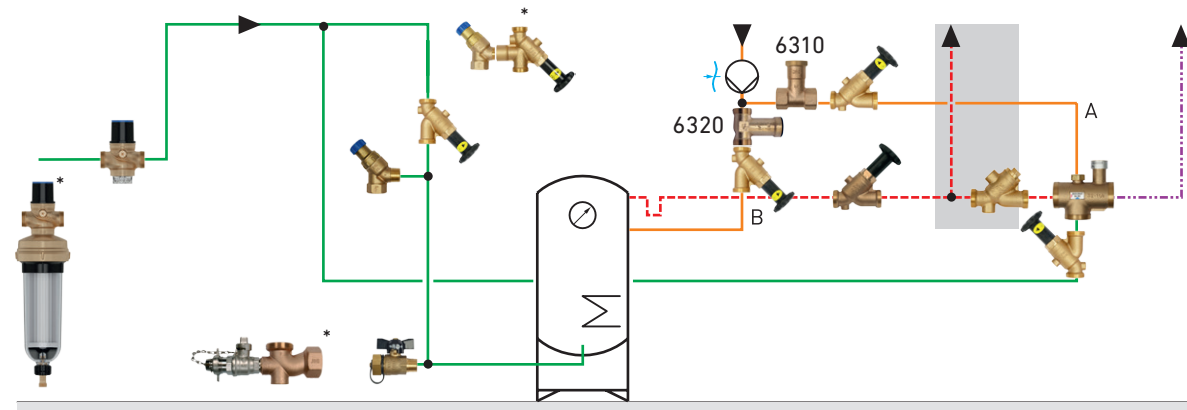

3

Observe legend/notes!

Mixed water installation with two circuits

*option

Option: Hot water outlet with circulation

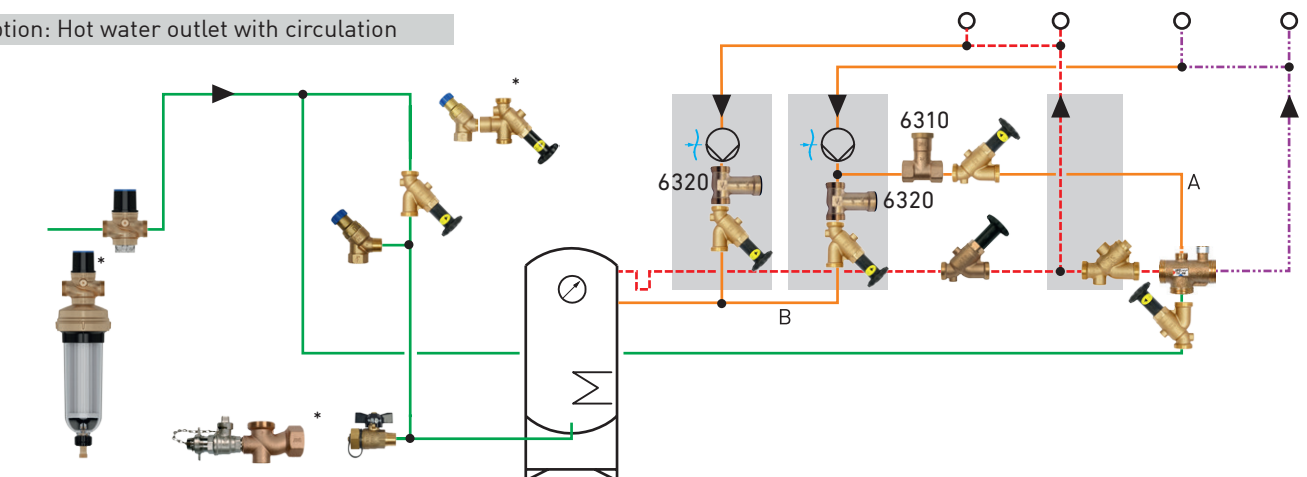

Installation Examples with JRGUMAT Thermostatic Mixing Valves

4 Observe legend/notes!

Mixed water installation with circulation pipe $\geq 3/4''$ *option

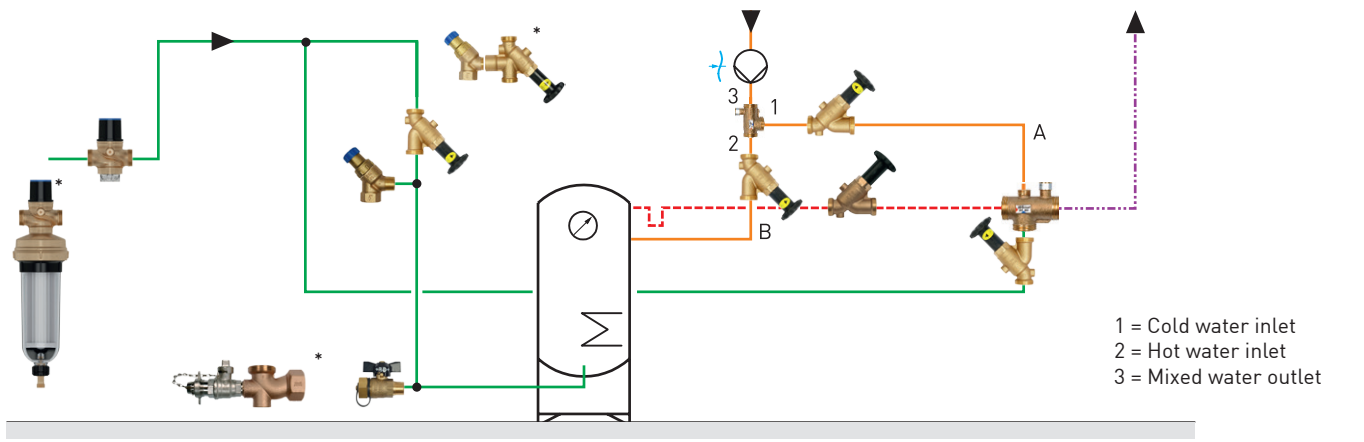

5 Observe legend/notes!

Mixed water installation with thermal disinfection *option

Option: Hot water outlet

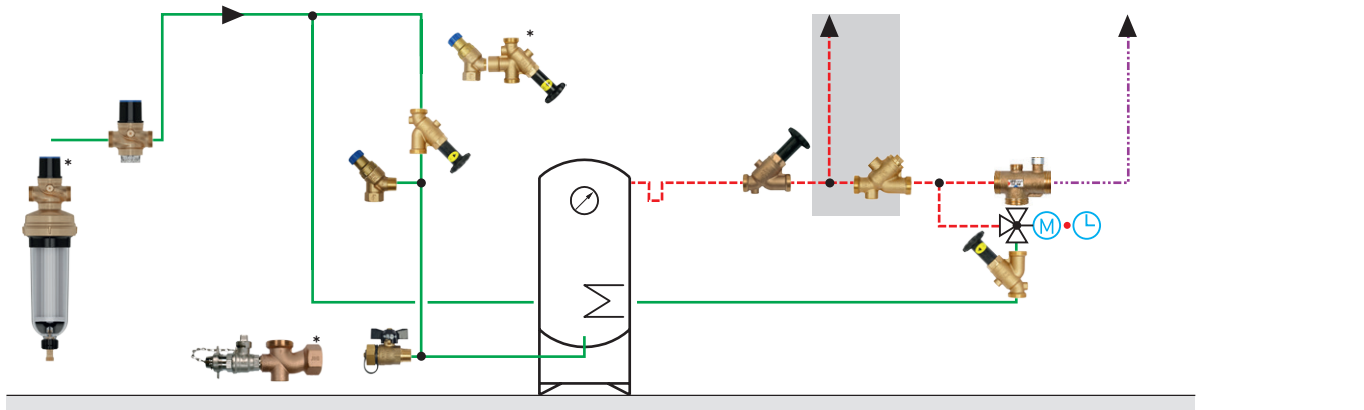

6 Observe legend/notes!

Mixed water installation with circulation and thermal disinfection *option

Option: Hot water outlet

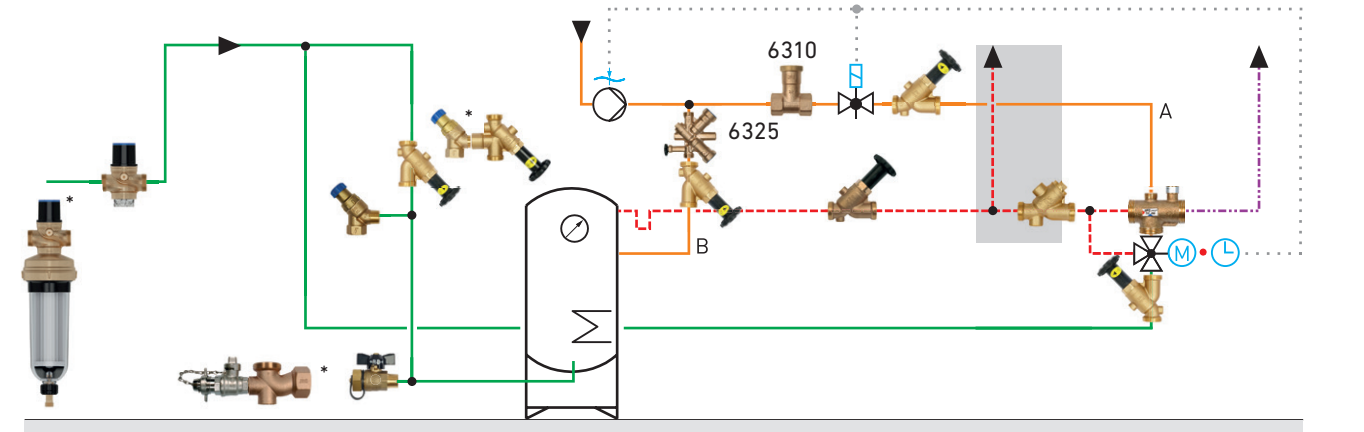

Installation Examples with JRGUMAT Thermostatic Mixing Valves

7 Observe legend/notes!

Regulating the storage capacity with JRGUMAT

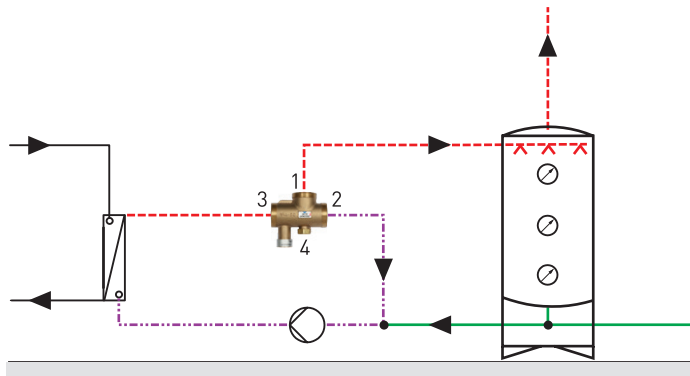

8 Observe legend/notes!

Fixed setpoint control at constant temperature (heating)

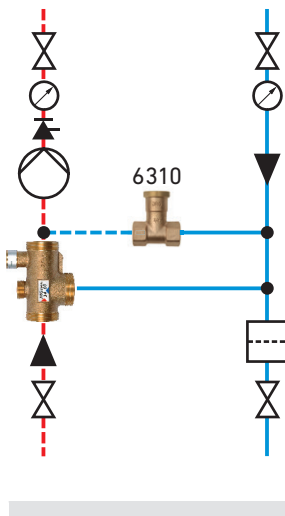

Overview Unions for JRGUMAT Thermostatic Mixing Valve 3400

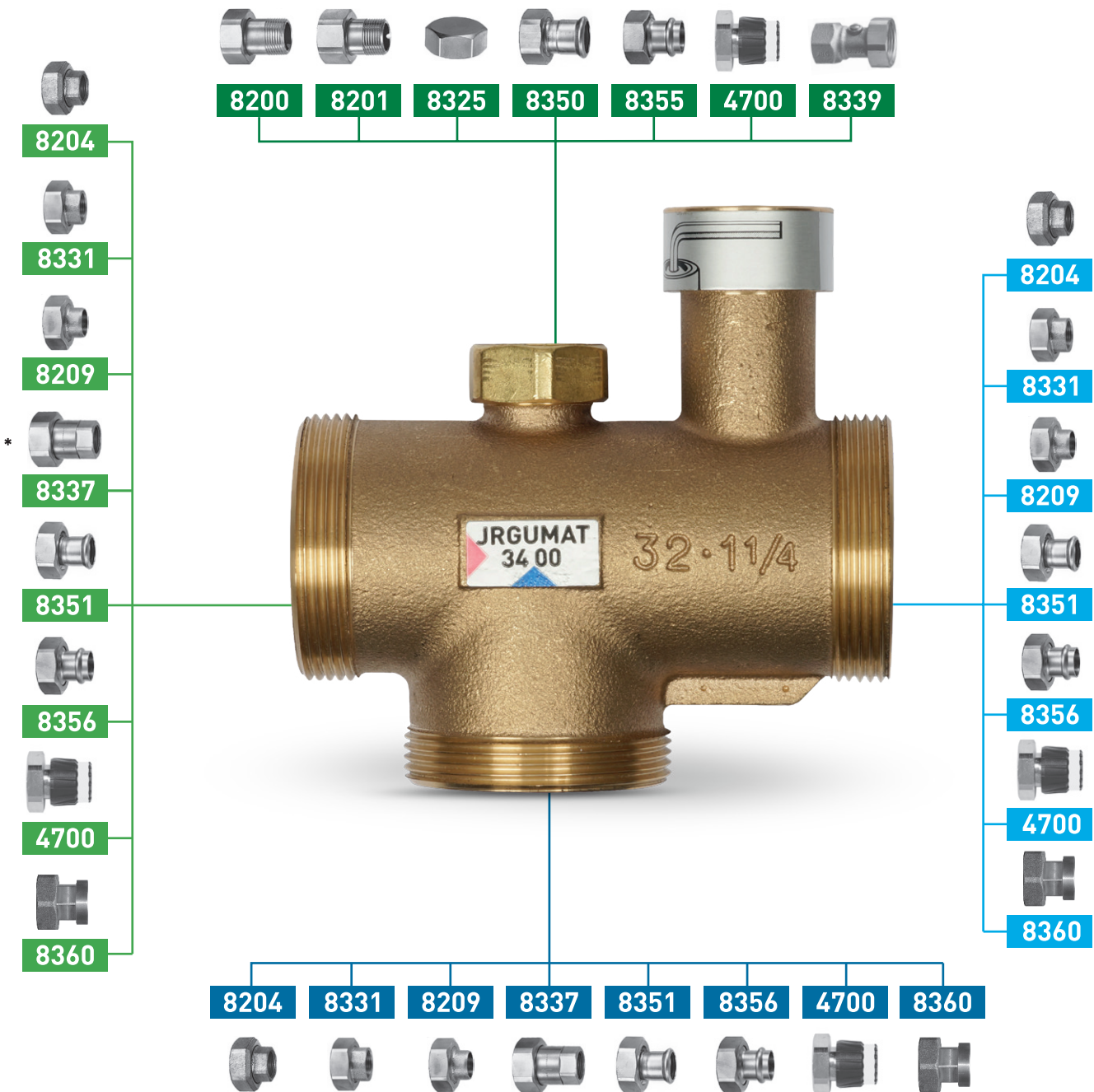

Use only the unions listed below.
AFM 34 gaskets must not be oiled or greased.

* Union 8337 with check valve only for
GN ½ (DN 15), or GN 15 (DN12) and
GN ¾ (DN 20), or GN 22 (DN 20).

Installation example

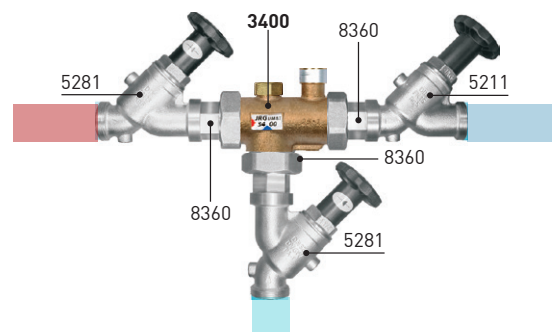

Overview Unions for JRGUMAT Thermostatic Mixing Valves 3410

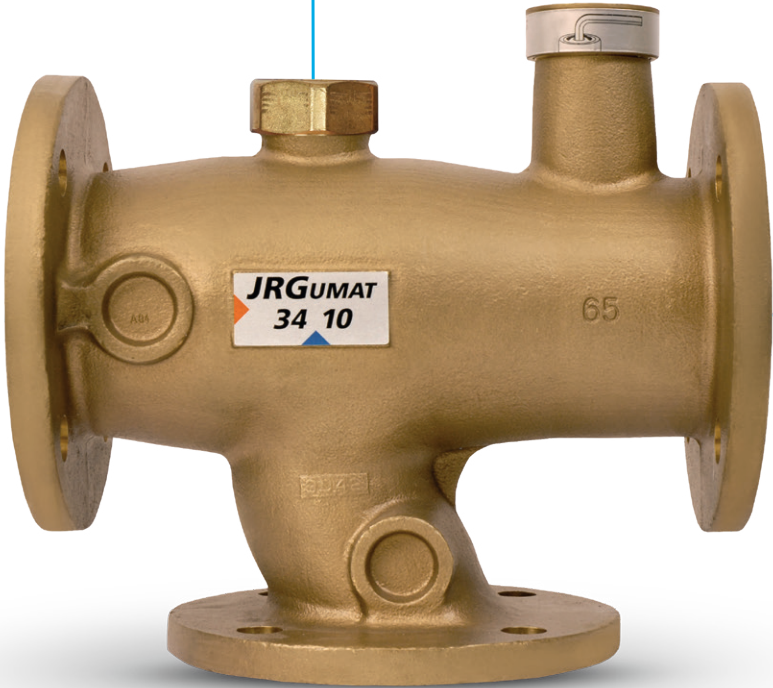
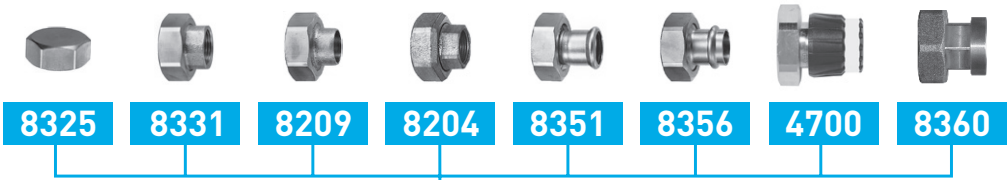

JRGUMAT 3400

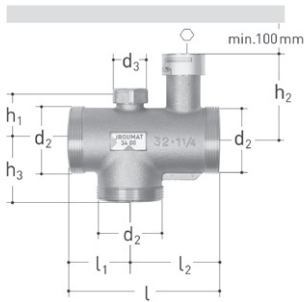

JRGUMAT Thermostatic mixing valve gunmetal

- Temperature: max. 90°C
 - Factory setting: 25 / 40 / 48 / 55 / 70°C (adjustable)
 - Material: gunmetal
 - Connection: male thread
- *as long as stock last

	DN (mm)	Thread Type	Size (inch)	range (°C)	Temperature (°C)	JRG Code	GF Code	Weight (kg)
	15	GN	1/2	20 - 30	25	3400.910	350 760 511	0.530
	15	GN	1/2	30 - 45	40	3400.912	350 760 512	0.530
*	15	GN	1/2	36 - 53	48	3400.914	350 760 517	0.530
	15	GN	1/2	45 - 65	55	3400.916	350 760 513	0.530
	15	GN	1/2	60 - 80	70	3400.918	350 760 514	0.530
	20	GN	3/4	20 - 30	25	3400.920	350 760 411	0.700
	20	GN	3/4	30 - 45	40	3400.922	350 760 412	0.700
*	20	GN	3/4	36 - 53	48	3400.924	350 760 417	0.670
	20	GN	3/4	45 - 65	55	3400.926	350 760 413	0.700
	20	GN	3/4	60 - 80	70	3400.928	350 760 414	0.701
	25	GN	1	20 - 30	25	3400.930	350 760 311	0.910
	25	GN	1	30 - 45	40	3400.932	350 760 312	0.910
*	25	GN	1	36 - 53	48	3400.934	350 760 317	0.910
	25	GN	1	45 - 65	55	3400.936	350 760 313	0.910
	25	GN	1	60 - 80	70	3400.938	350 760 314	0.910
	32	GN	1 1/4	20 - 30	25	3400.940	350 760 211	1.630
	32	GN	1 1/4	30 - 45	40	3400.942	350 760 212	1.630
*	32	GN	1 1/4	36 - 53	48	3400.944	350 760 217	1.590
	32	GN	1 1/4	45 - 65	55	3400.946	350 760 213	1.630
	32	GN	1 1/4	60 - 80	70	3400.948	350 760 214	1.590
	40	GN	1 1/2	20 - 30	25	3400.950	350 760 111	2.140
	40	GN	1 1/2	30 - 45	40	3400.952	350 760 112	2.140
*	40	GN	1 1/2	36 - 53	48	3400.954	350 760 117	2.140
	40	GN	1 1/2	45 - 65	55	3400.956	350 760 113	2.140
	40	GN	1 1/2	60 - 80	70	3400.958	350 760 114	2.100
	50	GN	2	20 - 30	25	3400.960	350 760 011	3.510
	50	GN	2	30 - 45	40	3400.962	350 760 012	3.510
*	50	GN	2	36 - 53	48	3400.964	350 760 017	3.510
	50	GN	2	45 - 65	55	3400.966	350 760 013	3.510
	50	GN	2	60 - 80	70	3400.968	350 760 014	3.510



JRGUMAT 3400

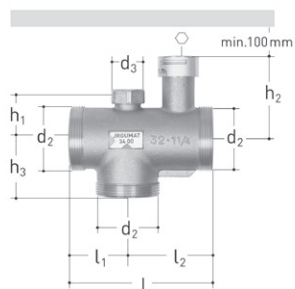

DN (mm)	Thread Type	d2 G (inch)	d3 G (inch)	h1 (mm)	h2 (mm)	h3 (mm)	l (mm)	l1 (mm)	l2 (mm)	PN (bar)	⊕ (mm)
15	GN	1 1/8			47	35	90	35	55	10	5
15	GN	1 1/8			47	35	90	35	55	10	5
* 15	GN	1 1/8			47	35	90	35	55	10	5
15	GN	1 1/8			47	35	90	35	55	10	5
15	GN	1 1/8			47	35	90	35	55	10	5
20	GN	1 1/4	1/2	32	49	40	100	40	60	10	5
20	GN	1 1/4	1/2	32	49	40	100	40	60	10	5
* 20	GN	1 1/4	1/2	32	49	40	100	40	60	10	5
20	GN	1 1/4	1/2	32	49	40	100	40	60	10	5
20	GN	1 1/4	1/2	32	49	40	100	40	60	10	5
20	GN	1 1/4	1/2	32	49	40	100	40	60	10	5
25	GN	1 1/2	3/4	36	51	43	110	43	67	10	5
25	GN	1 1/2	3/4	36	51	43	110	43	67	10	5
* 25	GN	1 1/2	3/4	36	51	43	110	43	67	10	5
25	GN	1 1/2	3/4	36	51	43	110	43	67	10	5
25	GN	1 1/2	3/4	36	51	43	110	43	67	10	5
32	GN	2	3/4	41	75	52	130	52	78	10	8
32	GN	2	3/4	41	75	52	130	52	78	10	8
* 32	GN	2	3/4	41	75	52	130	52	78	10	8
32	GN	2	3/4	41	75	52	130	52	78	10	8
32	GN	2	3/4	41	75	52	130	52	78	10	8
40	GN	2 1/4	3/4	50	77	58	150	58	92	10	8
40	GN	2 1/4	3/4	50	77	58	150	58	92	10	8
* 40	GN	2 1/4	3/4	50	77	58	150	58	92	10	8
40	GN	2 1/4	3/4	50	77	58	150	58	92	10	8
40	GN	2 1/4	3/4	50	77	58	150	58	92	10	8
50	GN	2 3/4	3/4	60	85	70	180	70	110	10	8
50	GN	2 3/4	3/4	60	85	70	180	70	110	10	8
* 50	GN	2 3/4	3/4	60	85	70	180	70	110	10	8
50	GN	2 3/4	3/4	60	85	70	180	70	110	10	8
50	GN	2 3/4	3/4	60	85	70	180	70	110	10	8

JRGUMAT 3410

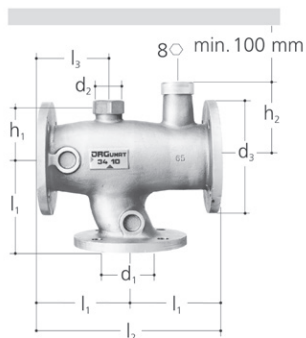

JRGUMAT Thermostatic mixing valve gunmetal Flanged

- Temperature: max. 90°C
 - Factory setting: 25 / 40 / 48 / 55°C (adjustable)
 - Material: gunmetal
 - Connection: flange
- *as long as stock last

	DN (mm)	d (mm)	range (°C)	Temperature (°C)	JRG Code	GF Code	Weight (kg)
	65	65	20 - 30	25	3410.601	350 767 214	22.500
	65	65	30 - 45	40	3410.605	350 767 215	22.500
*	65	65	36 - 53	48	3410.606	350 767 218	22.680
	65	65	45 - 65	55	3410.608	350 767 216	22.500
	80	80	20 - 30	25	3410.801	350 767 414	27.500
	80	80	30 - 45	40	3410.805	350 767 415	27.500
*	80	80	36 - 53	48	3410.806	350 767 418	27.734
	80	80	45 - 65	55	3410.808	350 767 416	27.500

	DN (mm)	d1 (mm)	d2 G (inch)	d3 (mm)	h1 (mm)	h2 (mm)	l1 (mm)	l2 (mm)	l3 (mm)	○ (mm)	◇ (mm)	PN (bar)
	65	65	1 ½	185	82	121	145	290	112	4	8	10
	65	65	1 ½	185	82	121	145	290	112	4	8	10
*	65	65	1 ½	185	82	121	145	290	112	4	8	10
	65	65	1 ½	185	82	121	145	290	112	4	8	10
	80	80	2	200	92	127	155	310	124	8	8	10
	80	80	2	200	92	127	155	310	124	8	8	10
*	80	80	2	200	92	127	155	310	124	8	8	10
	80	80	2	200	92	127	155	310	124	8	8	10

Unions

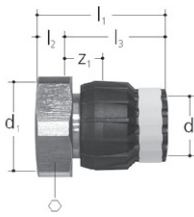

JRG Sanipex MT Transition union gunmetal

- Description: for JRG Sanipex d16/20, JRG Sanipex MT Pipes
 - Material: gunmetal, plastic
 - Connection: JRG Sanipex MT
- Not suitable for direct connection to water meters, as replacement only possible with JRG Sanipex MT ratchet torque wrench.

d (mm)	GN (inch)	JRG Code	GF Code	Weight (kg)	d1 G (inch)	l1 (mm)	l2 (mm)	l3 (mm)	z1 (mm)	⊙
16	½	4700.096	351 616 992	0.068	½	43.0	6.0	37.0	16.5	27
20	½	4700.098	351 620 968	0.071	½	50.0	6.0	44.0	17.5	27
16	¾	4700.102	351 616 994	0.066	¾	39.0	6.0	33.0	14.5	32
20	¾	4700.104	351 620 992	0.070	¾	44.0	6.0	38.0	15.5	32
26	¾	4700.106	351 626 919	0.100	¾	57.0	6.0	49.0	20.0	32
16	1 ¼	4700.120	351 616 996	0.130	1 ¼	41.0	8.0	33.0	14.5	46
20	1 ¼	4700.122	351 620 994	0.130	1 ¼	46.0	8.0	38.0	15.5	46
26	1 ¼	4700.124	351 626 995	0.150	1 ¼	55.5	8.0	47.5	18.5	46
32	1 ¼	4700.126	351 632 995	0.200	1 ¼	65.5	8.0	57.5	19.5	46
26	1 ½	4700.128	351 626 996	0.200	1 ½	56.5	9.0	47.5	18.5	54
32	1 ½	4700.130	351 632 996	0.260	1 ½	66.5	9.0	57.5	19.5	54
40	1 ½	4700.132	351 640 995	0.330	1 ½	77.5	9.0	68.5	23.5	55
40	2	4700.136	351 640 996	0.420	2	82.5	13.5	69.0	24.5	67
50	2 ¼	4700.138	351 650 996	0.667	2 ¼	82.5	11.0	71.5	34.0	72
63	2 ¾	4700.142	351 663 996	1.050	2 ¾	100.0	13.5	86.5	40.0	89

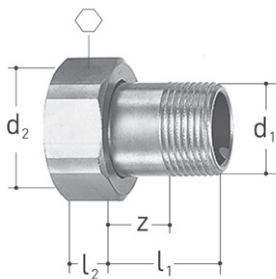

JRG Union brass

- Description: to 1684, 3400
- Material: brass
- Connection: female thread, male thread

GN (inch)	DN (mm)	JRG Code	GF Code	Weight (kg)	d1 R (inch)	d2 G (inch)	l1 (mm)	l2 (mm)
¾	10	8200.160	350 278 401	0.040	¾	½	22	6

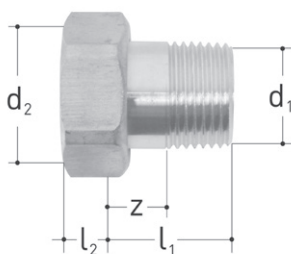

JRG Union brass

- Description: to 1300-1333, 1350-1363, 2100-2110, 2113, 2130-2140, 2143, 8201.402, 9601.040, 9603.040, 9606.040, 9695.480
- Material: brass
- Connection: male thread

GN (inch)	DN (mm)	JRG Code	GF Code	Weight (kg)	d1 R (inch)	d2 G (inch)	l1 (mm)	l2 (mm)	z
½	15	8201.240	350 331 701	0.060	½	¾	25	6	12
1 ¼	32	8201.480	350 332 001	0.290	1 ¼	1 ½	38	9	18

Unions

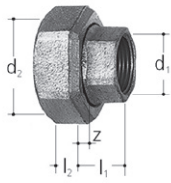

JRG Union malleable cast iron galvanized

- Description: to 1640, 1660-1663, 3400, 3410, 5130
- Material: malleable cast iron, galvanized
- Connection: female thread

GN (inch)	DN (mm)	JRG Code	GF Code	Weight (kg)	d1 Rp (inch)	d2 G (inch)	l1 (mm)	l2 (mm)	z (mm)
½	15	8204.240	350 485 601	0.150	½	1 ⅞	23	10	10
¾	20	8204.320	350 485 701	0.170	¾	1 ¼	24	11	9
1	25	8204.400	350 485 801	0.230	1	1 ½	27	11	10
1 ¼	32	8204.480	350 485 901	0.400	1 ¼	2	32	12	13
1 ½	40	8204.560	350 486 001	0.510	1 ½	2 ¼	34	13	15
2	50	8204.640	350 486 101	0.675	2	2 ¾	36	15	12

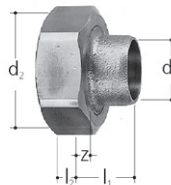

JRG Soldering union gunmetal

- Description: to 3400, 3410, 5120
- Material: gunmetal, brass
- * as long as stock last

d (mm)	DN (mm)	JRG Code	GF Code	Weight (kg)	d1 (mm)	d2 G (inch)	l1 (mm)	l2 (mm)	z (mm)
*	18	8209.018	350 484 102	0.120	18	1 ⅞	23	8	8
	22	8209.022	350 484 201	0.175	22	1 ¼	24	8	7
	22	8209.122	355 630 901	0.250	22	1 ½	24	9	7
	28	8209.028	350 484 301	0.260	28	1 ½	26	9	6
	35	8209.035	350 484 401	0.380	35	2	33	9	8
	42	8209.042	350 484 601	0.500	42	2 ¼	37	11	8
	54	8209.054	350 484 801	0.730	54	2 ¾	42	14	8

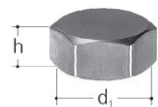

JRG Cap brass

- Description: to 3400, 3410
- Material: brass

DN (mm)	Size (inch)	PN (bar)	GN (inch)	JRG Code	GF Code	Weight (kg)	d1 G (inch)	h (mm)
15	½	10	½	8325.240	350 756 701	0.034	½	9
20	¾	10	¾	8325.320	350 756 801	0.040	¾	9
40	1 ½	10	1 ½	8325.560	350 769 801	0.190	1 ½	11
50	2	10	2	8325.640	350 769 901	0.230	2	11

Unions

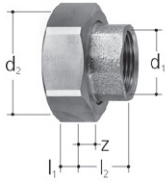

JRG Union gunmetal

- Description: to 3400, 3410, 5120
- Material: gunmetal
- Connection: female thread

GN (inch)	DN (mm)	JRG Code	GF Code	Weight (kg)	d1 Rp (inch)	d2 G (inch)	l1 (mm)	l2 (mm)	z (mm)
½	15	8331.240	350 217 101	0.150	½	1 ¼	8	23	10
¾	20	8331.320	350 253 301	0.150	¾	1 ¼	8	23	8
1	25	8331.400	350 253 401	0.230	1	1 ½	9	27	10
1 ¼	32	8331.480	350 253 501	0.380	1 ¼	2	10	29	10
1 ½	40	8331.560	350 253 601	0.460	1 ½	2 ¼	11	33	14
2	50	8331.640	350 253 701	0.740	2	2 ¾	14	36	12

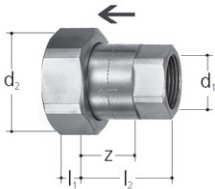

JRG Union gunmetal

- Description: to 3400
- Temperature: max. 90°C
- Material: gunmetal
- Connection: female thread
- Consisting of: back flow preventer, loose nut

GN (inch)	DN (mm)	JRG Code	GF Code	Weight (kg)	d1 Rp (inch)	d2 G (inch)	l1 (mm)	l2 (mm)	z (mm)	PN (bar)
½	15	8337.240	350 768 601	0.170	½	1 ⅝	8	39	26	10
¾	20	8337.320	350 768 801	0.235	¾	1 ¼	8	45	30	10

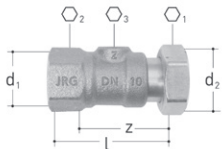

JRG union brass lead-free

- Description: 6320, 6325, 9910, 9920
- Temperature: max. 90°C
- Material: brass lead-free
- Connection: female thread
- Consisting of: ball valve, lockable, loose nut

GN (inch)	DN (mm)	JRG Code	Weight (kg)	GF Code	d1 Rp (inch)	d2 G (inch)	l (mm)	○1 (mm)	○2 (mm)	○3 (mm)	z (mm)	PN (bar)
½	15	8339.240	0.160	350 887 712	½	¾	58	30	27	5	47	16
¾	20	8339.320	0.250	350 887 912	¾	1	62	38	31	5	49	16

Unions

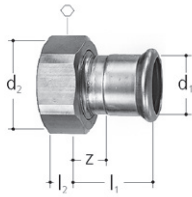

Mapress Union

- Description: to 1303, 1313, 1323, 1333, 1353, 1363, 1611, 1621, 2100-2140, 2161, 5010, 5015080, 5081, 5211, 5281, 6320, 9910, 9920
- Connection: Mapress
- Consisting of: loose nut, press-socket, flat sealed

d1 (mm)	DN (mm)	JRG Code	GF Code	Weight (kg)	d2 G (inch)	l1 (mm)	l2 (mm)	z (mm)	⊙
15	12	8350.015	355 600 201	0.080	¾	31	7	11	30
18	15	8350.018	355 600 207	0.100	¾	31	7	12	30

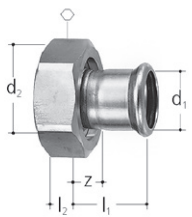

Mapress Union

- Description: to 1503, 1643, 1663, 2170, 3400, 5103, 5120, 5133, 5085, 5086
- Connection: Mapress
- Consisting of: loose nut, press-socket, flat sealed

d1 (mm)	DN (mm)	JRG Code	GF Code	Weight (kg)	d2 G (inch)	l1 (mm)	l2 (mm)	z (mm)	⊙
18	15	8351.018	355 600 407	0.157	1 ¼	39	8	18	46
22	20	8351.022	355 600 402	0.140	1 ¼	42	8	21	46
22	20	8351.122	355 600 408	0.208	1 ½	42	9	21	54
28	25	8351.028	355 600 403	0.210	1 ½	44	9	21	54
35	32	8351.035	355 600 404	0.350	2	49	11	23	66
42	40	8351.042	355 600 405	0.413	2 ¼	52	11	22	72
54	50	8351.054	355 600 406	0.610	2 ¾	57	14	22	89

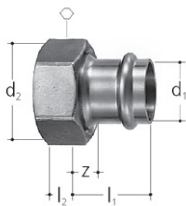

Optipress Union

- Description: to 1303, 1313, 1323, 1333, 1353, 1363, 1611, 1621, 2100-2140, 2161, 5010, 5015080, 5081, 5211, 5281, 6320, 9910, 9920
- Connection: Optipress / Sanpress
- Consisting of: loose nut, press-socket, flat sealed

d1 (mm)	DN (mm)	JRG Code	GF Code	Weight (kg)	d2 G (inch)	l1 (mm)	l2 (mm)	z (mm)	⊙
15	12	8355.015	355 600 601	0.100	¾	37	9	13	31
18	15	8355.018	355 600 602	0.080	¾	40	9	16	31
22	20	8355.022	355 600 603	0.110	1	39	9	15	37
28	25	8355.028	355 600 604	0.170	1 ¼	42	11	18	46
35	32	8355.035	355 600 605	0.210	1 ½	44	13	18	53
42	40	8355.042	355 600 606	0.360	1 ¾	61	13	20	60
54	50	8355.054	355 600 607	0.540	2 ¾	61	16	15	78

Unions

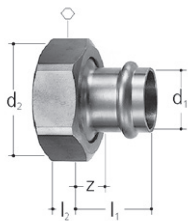

Optipress Union

- Description: to 1503, 1643, 1663, 2170, 3400, 5015, 5016, 5103, 5120, 5133, 5085, 5086
- Connection: Optipress / Sanpress
- Consisting of: loose nut, press-socket, flat sealed

d1 (mm)	DN (mm)	JRG Code	GF Code	Weight (kg)	d2 G (inch)	l1 (mm)	l2 (mm)	z (mm)	⊙
15	12	8356.015	355 600 801	0.132	1 1/8	39	10	15	42
18	15	8356.018	355 600 808	0.180	1 1/4	40	9	18	46
22	20	8356.022	355 600 802	0.250	1 1/4	36	11	12	50
22	20	8356.122	355 600 807	0.180	1 1/2	36	9	12	52
28	25	8356.028	355 600 803	0.190	1 1/2	38	12	14	52
35	32	8356.035	355 600 804	0.280	2	39	12	15	64
42	40	8356.042	355 600 805	0.580	2 1/4	48	12	12	73
54	50	8356.054	355 600 806	0.640	2 3/4	62	17	15	88

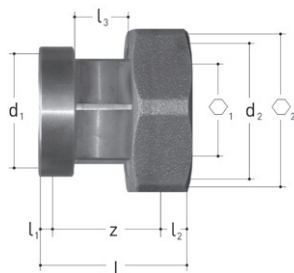

JRG Socket connection gunmetal

- Description: to 1611, 1631, 2191, 3400, 5120, 5211, 5281
- Material: gunmetal
- Connection: female thread
- Consisting of: loose nut, press-socket, flat sealed

Size (inch)	DN (mm)	PN (bar)	JRG Code	GF Code	Weight (kg)
1/2	15	16	8360.015	351 061 403	0.219
3/4	20	16	8360.020	351 061 413	0.300
1	25	16	8360.025	351 061 423	0.451
1 1/4	32	16	8360.032	351 061 433	0.670
1 1/2	40	16	8360.040	351 061 443	0.730
2	50	16	8360.050	351 061 453	1.170

d1 G (inch)	d2 G (inch)	l (mm)	l1 (mm)	l2 (mm)	l3 (mm)	⊙1	⊙2	z (mm)
3/4	1 1/8	56	6	8	22	22	41	42
1	1 1/4	57	7	8	22	27	46	42
1 1/4	1 1/2	61	8	9	22	32	54	44
1 1/2	2	65	9	9	22	41	66	47
1 3/4	2 1/4	68	10	11	22	48	72	48
2 3/4	2 3/4	74	11	14	22	58	89	49

Accessories

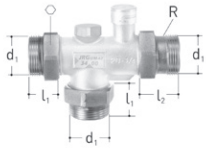

JRGUMAT change over set gunmetal

- Material: gunmetal
- Transition JRGUMAT 3350 to 3400
- R = DN 40 and 50 two half rings – see assembly instructions

DN (mm)	Thread Type	Size (inch)	JRG Code	GF Code	Weight (kg)	d1 G (inch)	L1 (mm)	L2 (mm)
20	GN	¾	3480.320	350 597 601	0.490	1 ¼	30.5	40.5
25	GN	1	3480.400	350 597 701	0.800	1 ½	38.0	34.0
32	GN	1 ¼	3480.480	350 597 801	1.050	2	39.5	33.5
40	GN	1 ½	3480.560	350 597 901	1.250	2 ¼	44.5	30.5
50	GN	2	3480.640	350 598 001	1.715	2 ¾	44.5	34.5

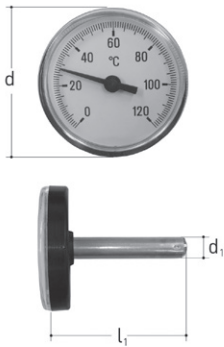

JRG Thermometer brass

- Description: to 8348.080
- Material: brass, plastic

d (mm)	JRG Code	GF Code	Weight (kg)	d1 (mm)	L1 (mm)
52	8348.001	350 830 194	0.030	9	62

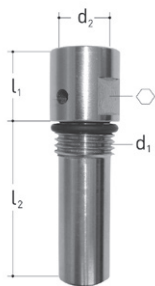

JRG Sleeve stainless steel

- Description: to 3500, 3510, 6325
- Material: stainless steel, EPDM

GN (inch)	DN (mm)	JRG Code	GF Code	Weight (kg)	d1 G (inch)	d2 (mm)	L1 (mm)	L2 (mm)	⊕
¼	8	8348.080	350 830 192	0.030	¼	9	15	35	13

Accessories

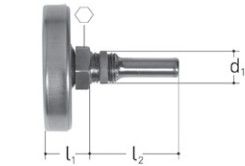
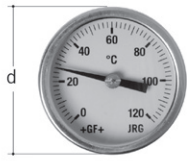

JRG Thermometer stainless steel

- Description: to 3500, 3510, 6325
- Material: stainless steel

GN (inch)	DN (mm)	JRG Code	GF Code	Weight (kg)	d (mm)	d1 (inch)	G (mm)	L1 (mm)	L2 (mm)	⊘
1/4	8	8349.080	350 830 191	0.080	52	1/4	19	35	17	

Spare Parts

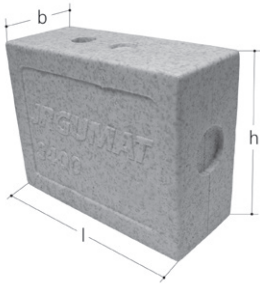

JRGUMAT Insulation box EPS

- Material: EPS

GN (inch)	DN (mm)	GF Code	Weight (kg)	l (mm)	b (mm)	h (mm)
½	15	350 762 301	0.043	170	74	140
¾	20	350 762 201	0.043	190	80	150
1	25	350 762 101	0.068	190	90	145
1 ¼	32	350 762 001	0.096	221	100	180
1 ½	40	350 761 901	0.110	250	104	195
2	50	350 761 801	0.210	290	125	220

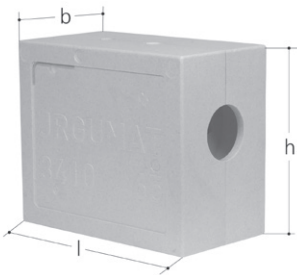

JRGUMAT Insulation box EPS

- Material: EPS

GN (inch)	DN (mm)	GF Code	Weight (kg)	l (mm)	b (mm)	h (mm)
2 ½	65	350 767 701	0.476	395	335	220
3	80	350 767 801	0.238	420	355	230



JRGUMAT Gasket set AFM34 For 3400

- Material: AFM34

GN (inch)	JRG Code	GF Code	Weight (kg)
½	3415.240	350 760 510	0.010
¾	3415.320	350 760 410	0.012
1	3415.400	350 760 310	0.015
1 ¼	3415.480	350 760 210	0.020
1 ½	3415.560	350 760 110	0.025
2	3415.640	350 760 010	0.028

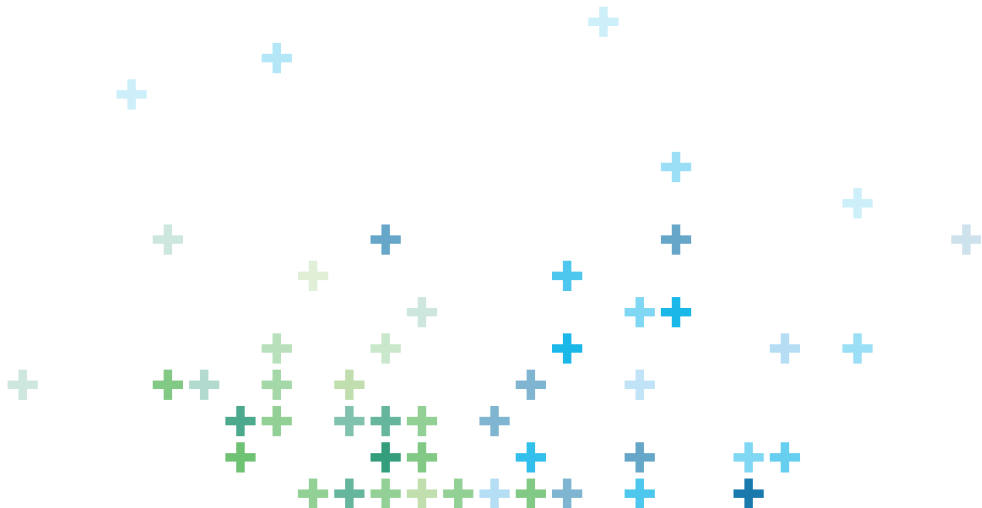

Local support around the world

Visit our webpage to get in touch with your local specialist:

www.gfps.com/our-locations



Ident. Nr. 3724262 / 02.25 / ©Georg Fischer JRG AG

BFS Code 1161617_v1_02_2025
Production: GF BFS / SDE

The information and technical data (altogether "Data") herein are not binding, unless explicitly confirmed in writing. The Data neither constitutes any expressed, implied or warranted characteristics, nor guaranteed properties or a guaranteed durability. All Data is subject to modification. The General Terms and Conditions of Sale of Georg Fischer Piping Systems apply.