

4

3

2

1

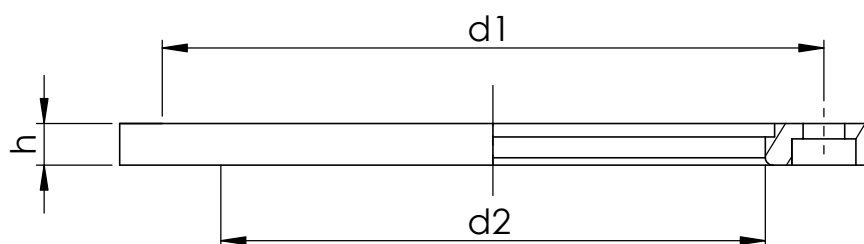
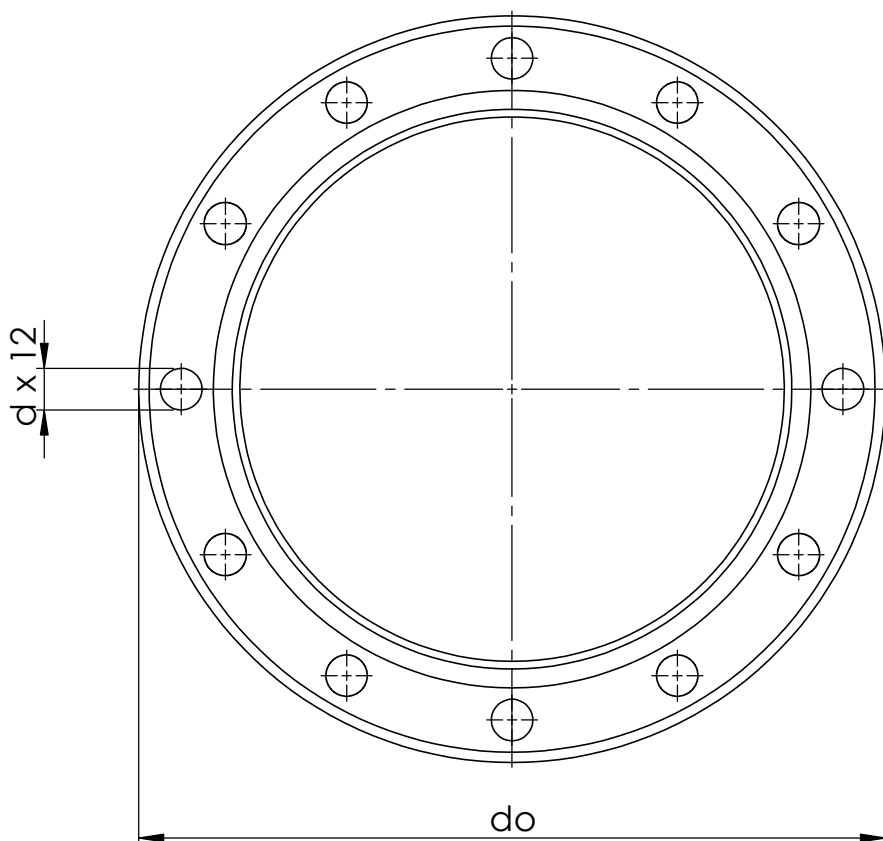

Item	Size (flange/collar)	d	Bolt size	d1	d2	do	h	Operating pressure (max)
1068666	250/250	22	M20	350	288	395	22	10

Uponor

Description

INFRA
Mounting dimensions
Pressure flange DN250-300 PN10 Epox
Flanges

Drawing number

Z_Pressure_flange_DN250_PN10_EPOX

Sheet: 1/1

