

Oil separator-PE-6-2,5 class 1		NS	6
Effective volume		l	3378
Sludge storage volume		l	2500
Oil storage volume		l	402
Bottom-Inlet		mm	1710
Bottom-Outlet		mm	1680
1.	Tank PE, Ø-	mm	1790
2.	Riser connection	DN	600
3.	Riser	DN	600
4.	Cover	mm	600
5.	Inlet	mm	160
6.	Outlet	mm	160
7.	Automatic closure	mm	160
8.	Coalescence unit	NS	6
9.	Cable connection	DN	50
10.	Sludge level sensor*	pc.	
11.	Oil level sensor*	pc.	
12.	High level sensor*	pc.	
13.	Alarm control unit	pc.	

* Sensor installation height available in mounting instructions.

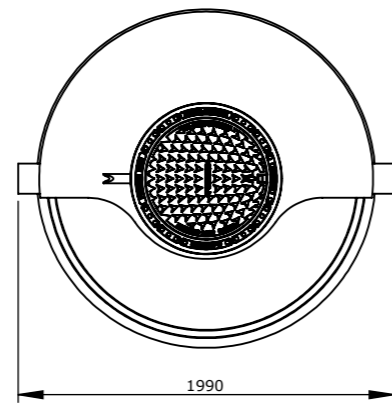

We reserve the right to changes.



City/Village	Block/Yard	Lot/Rno.	Notes from administrative authority	
Construction act			Drawing type	Number
Construction site: name and address			Qualifies	Scale
			Oil separator-PE-6-2,5 class 1	1:40
Designer: name, date and signature			Planning, work no. and drawing no.	Modification