

Installation manual

Clean Pump Chamber

Uponor

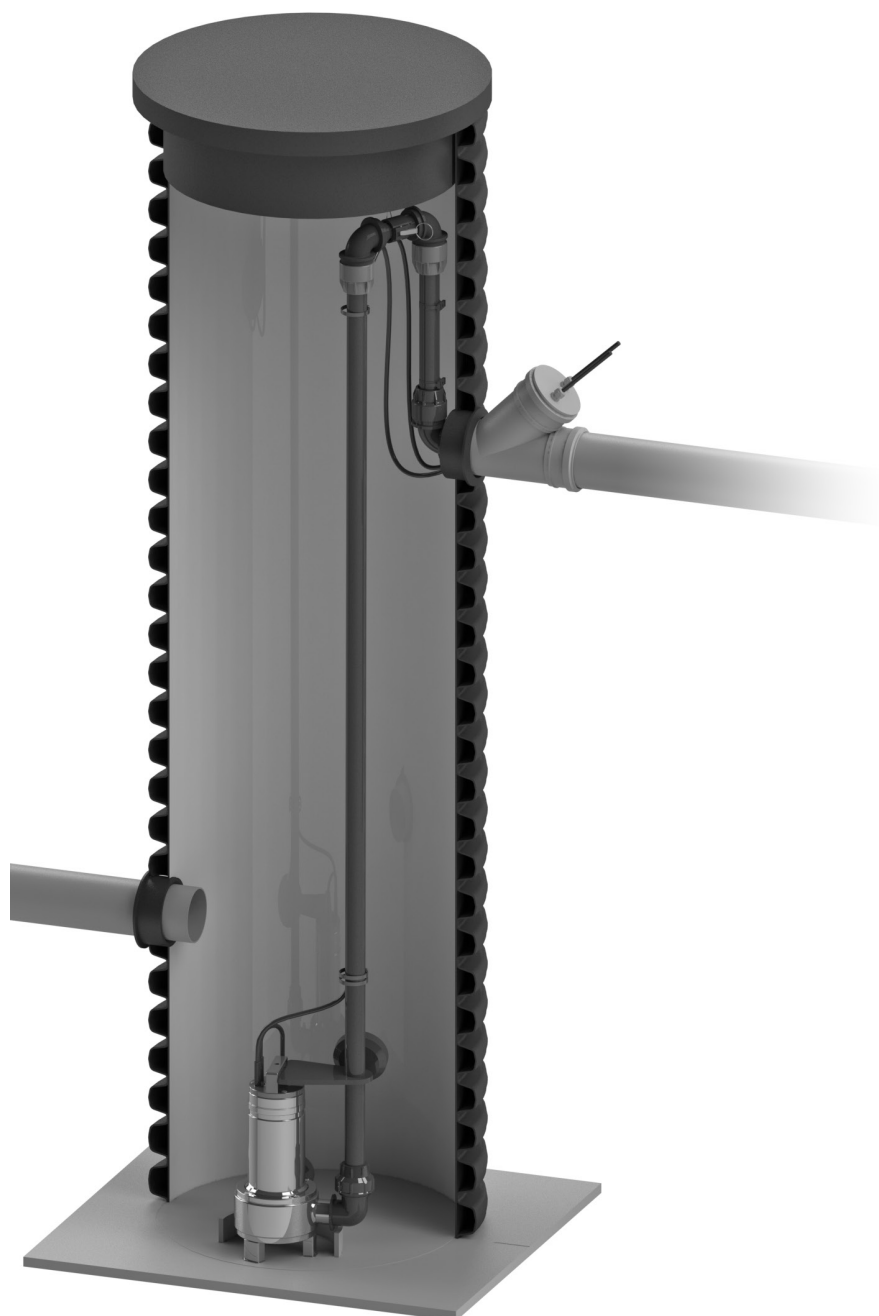

Clean Pump Chamber installation manual

1. Intended use Clean Pump Chamber

For pumping all household wastewater to the Clean I & II treatment plant. Ventilated trough.

Product	Uponor No.
Clean Pump Chamber 2,3m	1140383

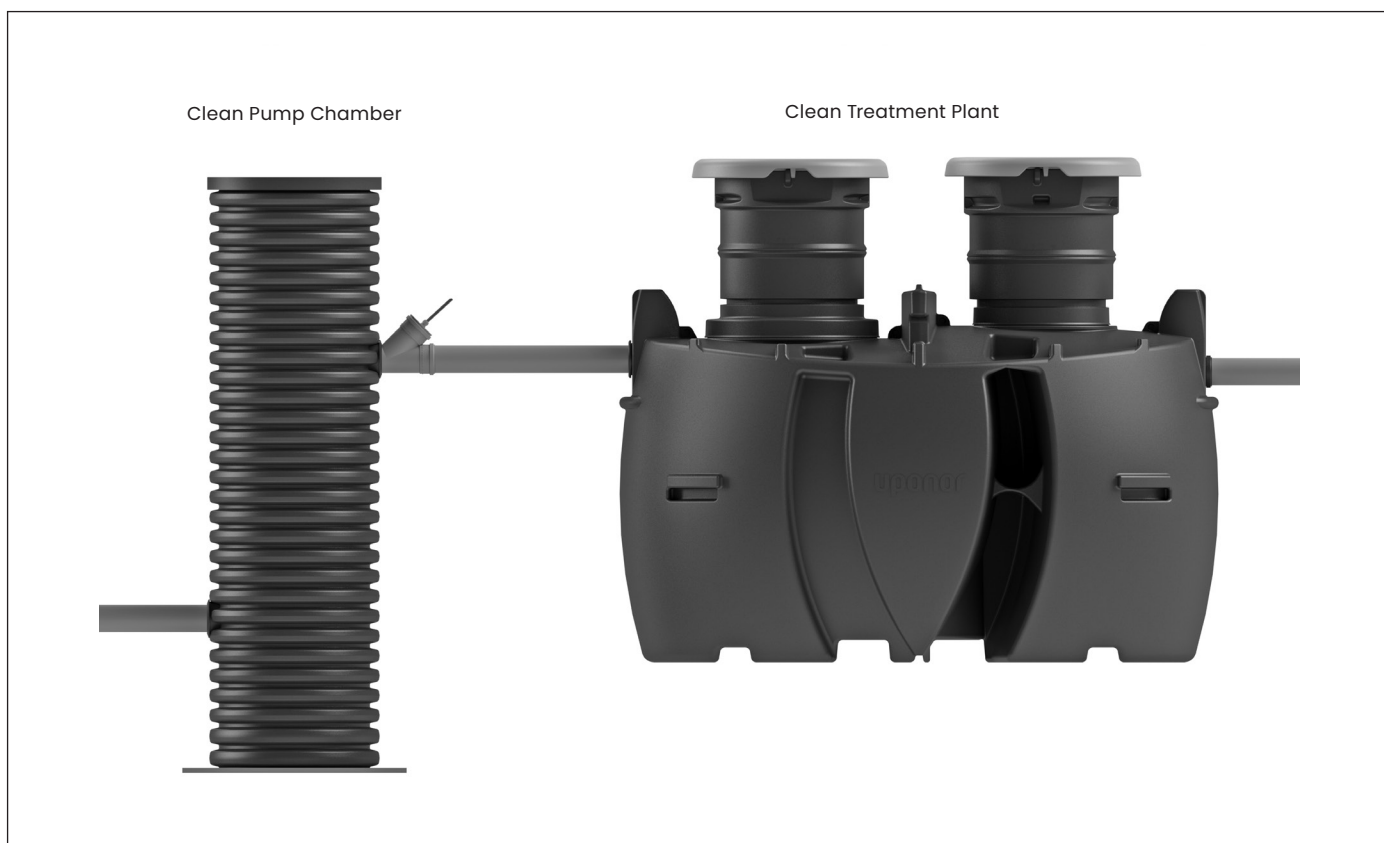

Contents

1. Intended use Clean Pump Chamber	2
2. Before installation.....	3
3. Pump chamber preparations	4
4. Pump chamber installation	6
5. Pump mounting.....	6
6. Pump chamber extension.....	9
7. Isolation if needed.....	10
8. Service.....	10
9. Pump technical data.....	10
10. Contact info pump service.....	10
Operation journal.....	11

We reserve the right to make changes.

2. Before installation

Open the pump chamber package and check that you have all the equipment needed in the installation.

List of tools needed in the installation

- Drill saw Ø 138mm
- Drill Ø 16mm
- Lubrication
- Level

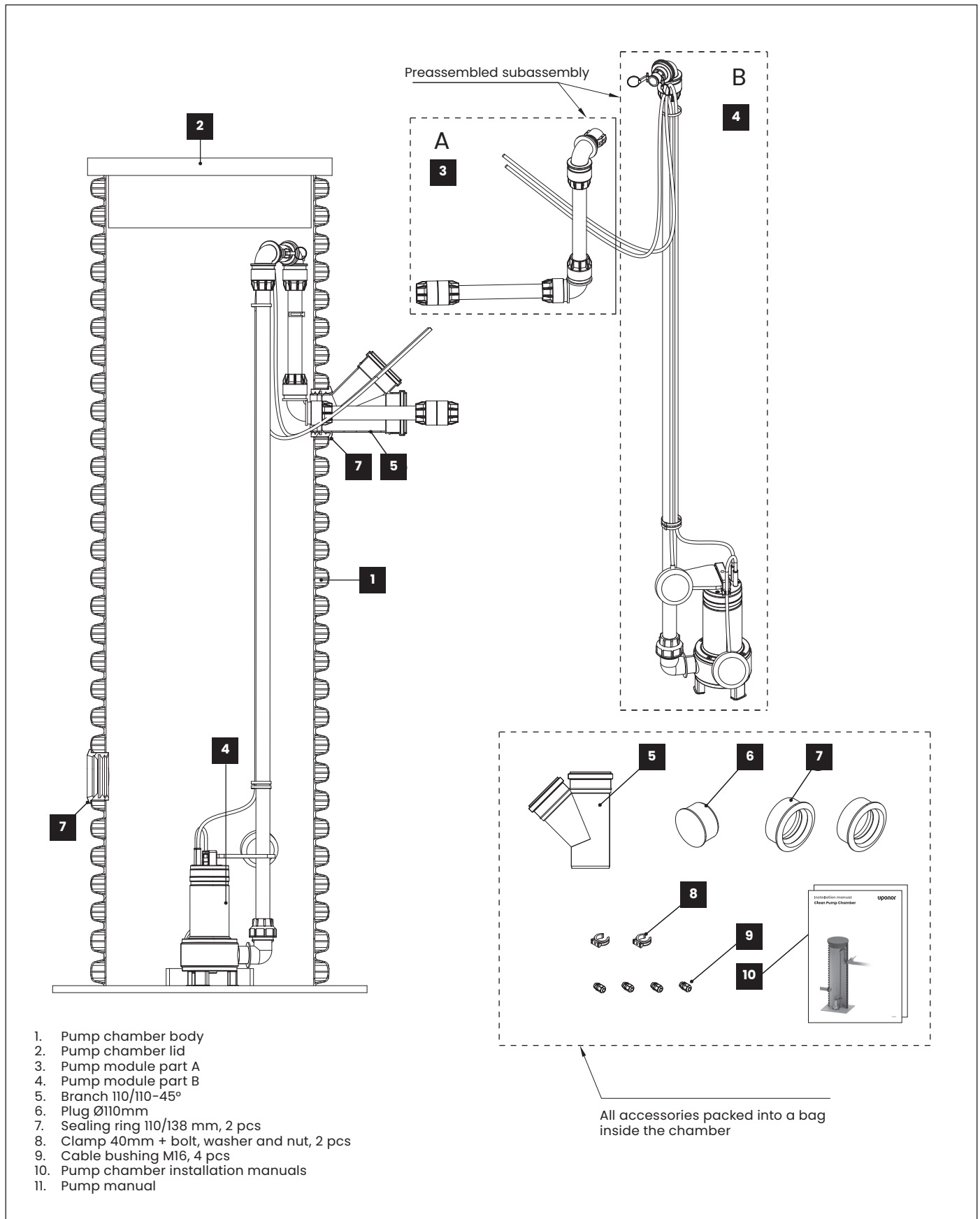

1. Pump chamber body
2. Pump chamber lid
3. Pump module part A
4. Pump module part B
5. Branch 110/110-45°
6. Plug Ø110mm
7. Sealing ring 110/138 mm, 2 pcs
8. Clamp 40mm + bolt, washer and nut, 2 pcs
9. Cable bushing M16, 4 pcs
10. Pump chamber installation manuals
11. Pump manual

List of components/Picture 1

Issues to take into consideration in the planning of the installation:

- Inlet sewer pipe height X
- Distance and vertical height difference between inlet sewer and Clean I/II inlet Y (Picture 2)
- It is recommended to place the pump chamber and the treatment plant close to each other, min distance 1m, max 5m.

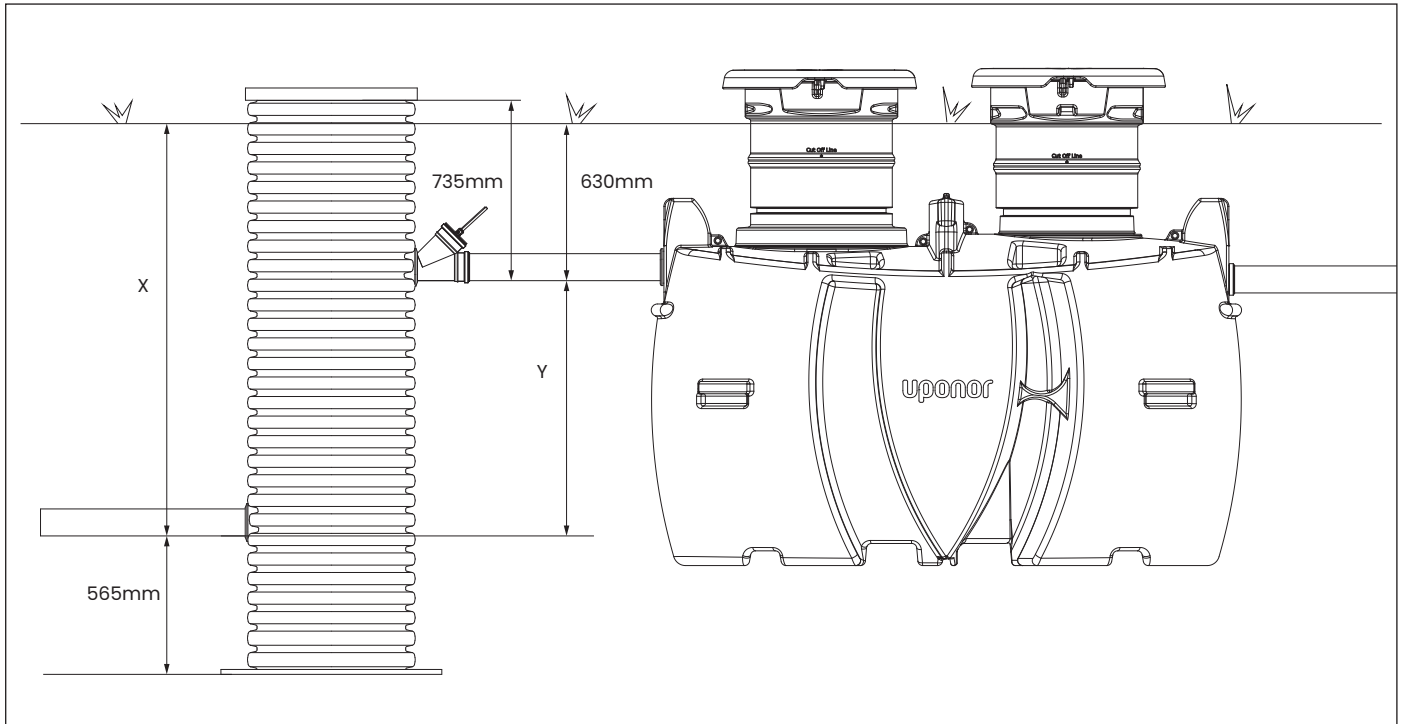

Installation dimensions (Picture 2)

3. Pump chamber preparations

Inlet

- Inlet hole is pre-drilled

Chamber height

- Determine the vertical height difference Y between the sewer pipe and treatment plant inlet (Picture 2).

Y = X - 630mm

- Chamber total height is **565mm + Y + 735mm**
- The height of standard chamber is 2.35m
- If the needed height is below 2.35m, cut the chamber in right length
- If the pump chamber is shortened, the pump module part B needs to be shortened the same amount (picture 3)
- If the needed height is above 2.35m and below 3.7m, use chamber extension

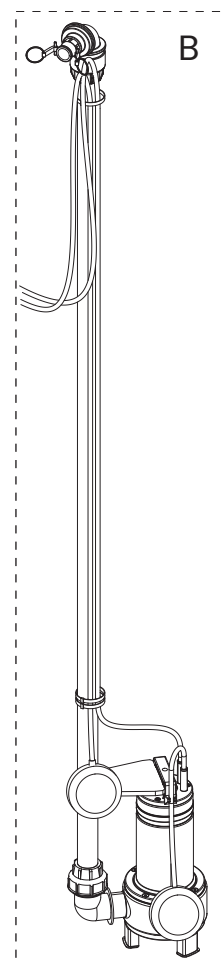

Picture 3

Outlet

- Place the outlet to opposite site of the chamber to the pre-drilled inlet. Check point 1 (picture 4).
- The center of the outlet is 680mm (= 9th corrugation) from chamber top. Mark a drill mark and drill the hole with a $\varnothing 138\text{mm}$ drill-saw
- Mount the $\varnothing 110\text{mm}$ sealing

- Lubricate the sealing and push the Branch 110/110-45° from outside in
- Drill two 16mm holes (picture 5) in the Plug 110 and mount cable bushings in the holes and push the Plug in the Branch

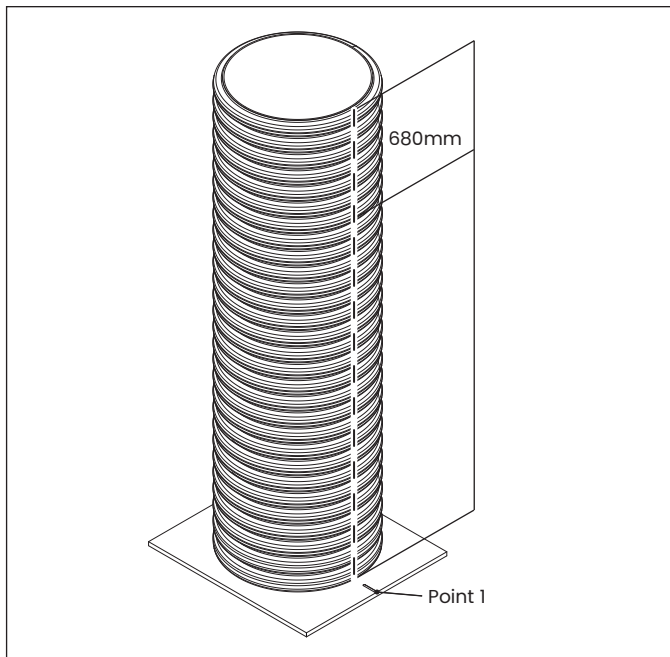

Picture 4

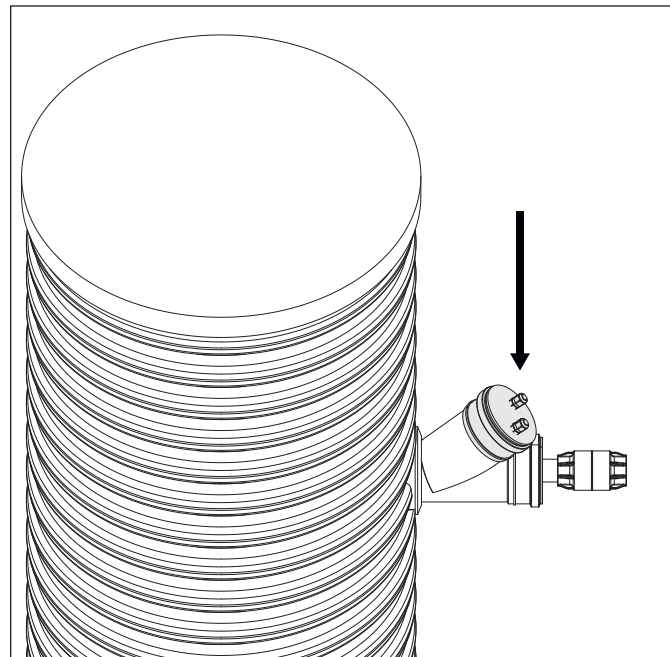

Picture 5

Pump module fixing clamps

- Drill 8mm holes between 5th and 6th corrugation and between 7th and 8th corrugation, for fixing clamps parallel to the outlet
- Mount the 40mm fixing clamps
- Fix the pump module A to the fixing clamps

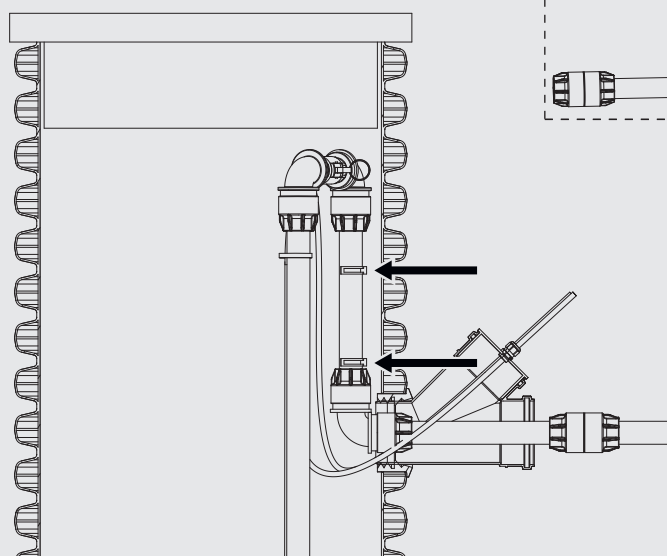

Picture 6

4. Pump chamber installation

Dig the bottom of the cavity 35cm deeper than the installation depth. Pour a layer of gravel or compactable sand on the bottom of the cavity. Lay the layer level and compact it. Secure the right height of the bottom of the cavity. Lift the pump chamber to the cavity. Secure that it stands upright.

Backfill the cavity to the level of the inlet pipe. Use gravel or compactable sand, and compact in 30cm layers.

Inlet

Connect inlet pipe to the inlet hole. The inlet pipe shall extend 30–50mm inside the chamber (picture 7).

Note! If it extends too much inside the chamber, it makes it more difficult to remove the pump from the chamber for maintenance.

Outlet

Backfill the cavity to the level of the outlet pipe. Use gravel or compactable sand, and compact in 30cm layers.

Mount the 40mm pressure pipe and the 110mm ventilation pipe to the outlet. The pipes shall extend inside the treatment plant as defined in picture 7.

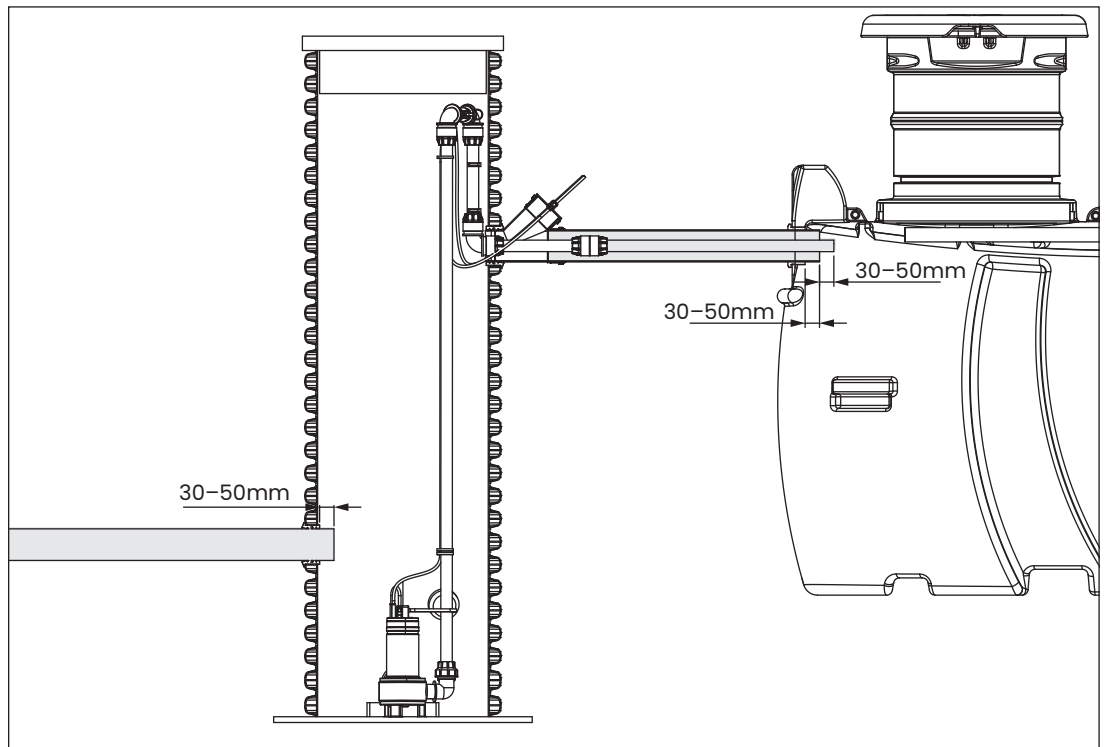

Picture 7, installation inlet

5. Pump mounting

The pump chamber is delivered with a factory-assembled pump module, which is in two pieces, A and B. The pump is steered with a float switch. The float switch has been pre-adjusted to give a pump batch of 70–80l at a time. There is a high water float switch attached to the pump module. Secure that the cable setups are according to picture 8.

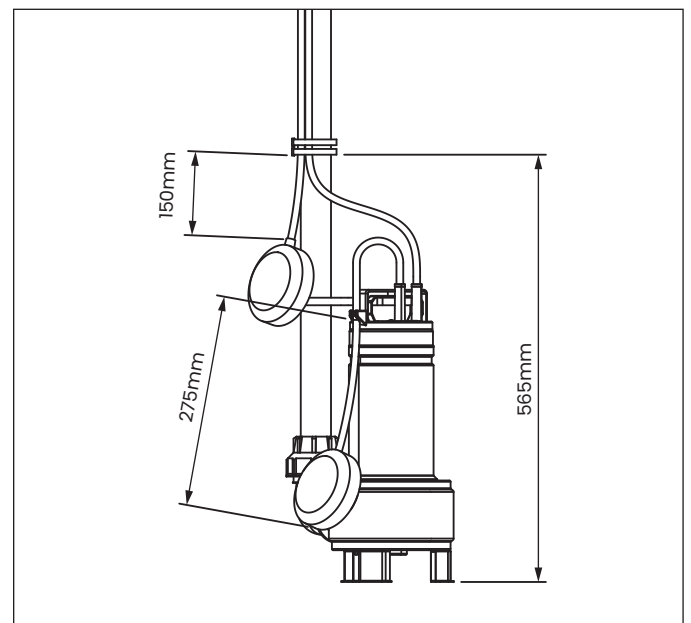

Picture 8, pump and setup of float switches with measurements

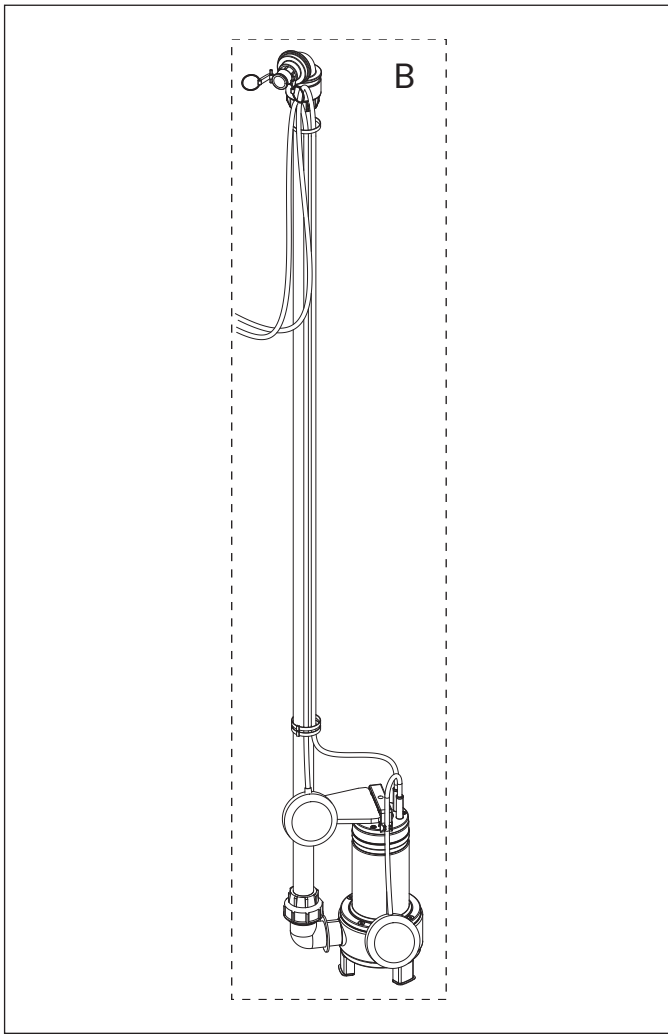

Lift the pump module (B) to the pump chamber. Place the pump inside the arc (Picture 10). Connect the camlocks of pump module A and B. Make sure, that the power cables are fastened properly with a cable tie.

Picture 9

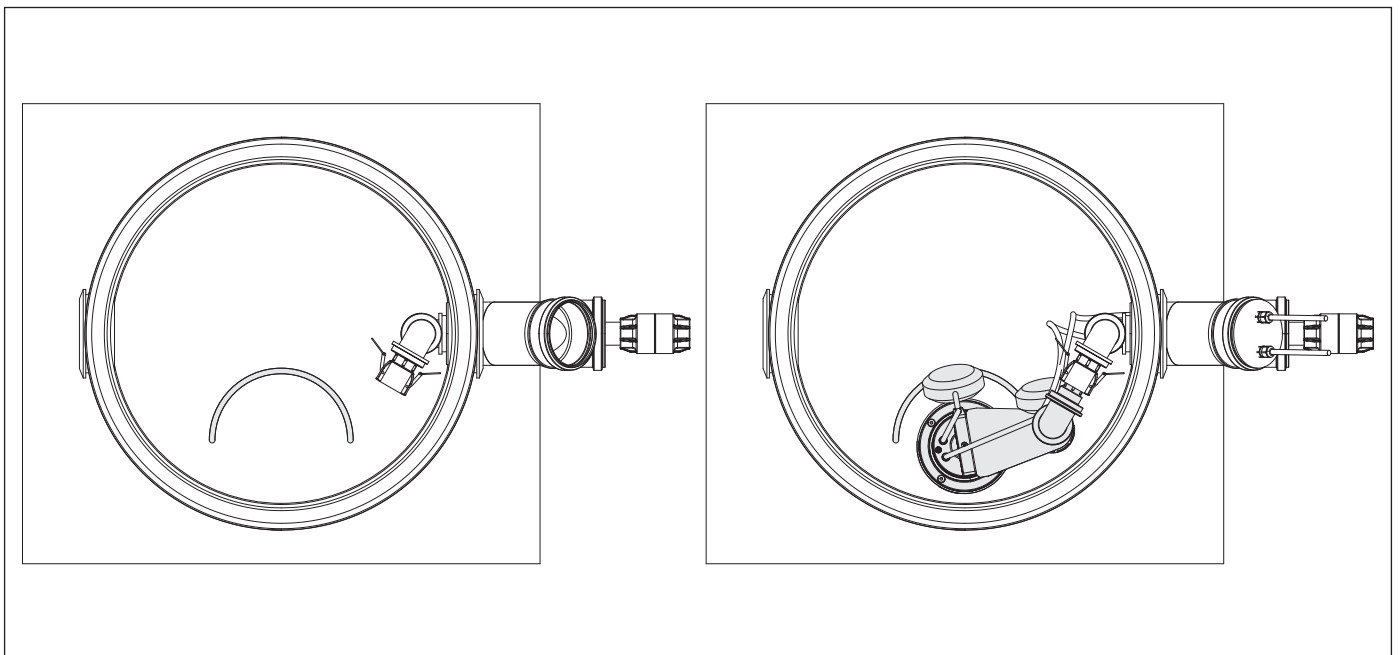

Picture 10

After installing the pump chamber, it is important to secure that the float switches move freely up and down so that the pump starts and stops correctly and the high water alarm functions.

An authorized electrician shall make the electrical connections. Bring the power cables of the pump and the high water float switch out through the cable bushings of the pump on the Branch 110/110-45°. Extend the cables MCMK 3 x 1,5mm². Connect the power cable of the pump to the connection box of Clean treatment plant (picture 11).

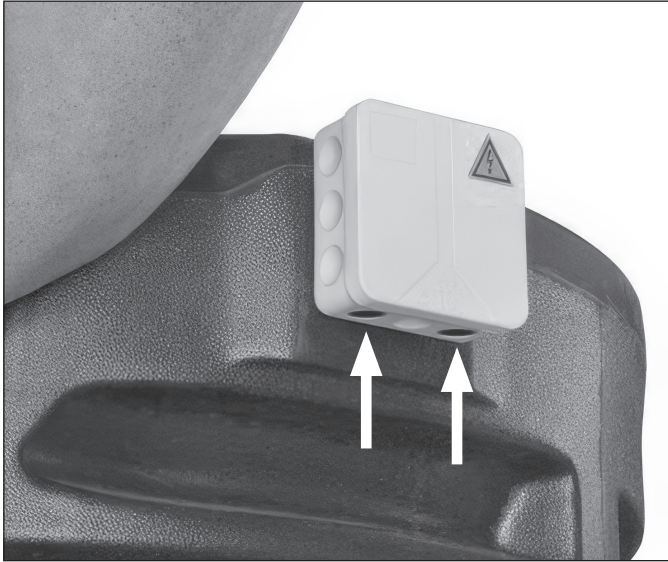

Picture 11

The high water alarm cable is to be connected to the switch cabinet of the Clean I/II treatment plant through a cable bushing. Bring the cable in to the process tank riser. Cable length inside process tank riser shall be no less than 3m, MCMK 3 x 1,5mm². Bundle the cable with cable ties on the side of the robot hose (picture 12) and

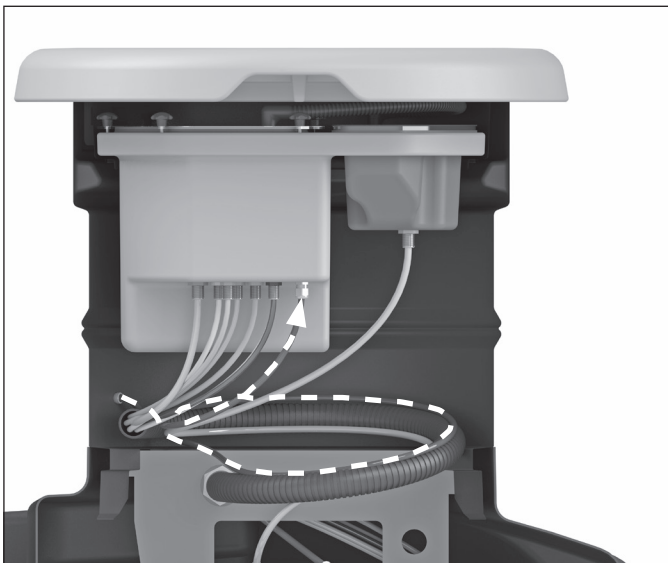

Picture 12

bring it in the switch cabinet through the bottom of the casing, using a cable bushing (picture 13).

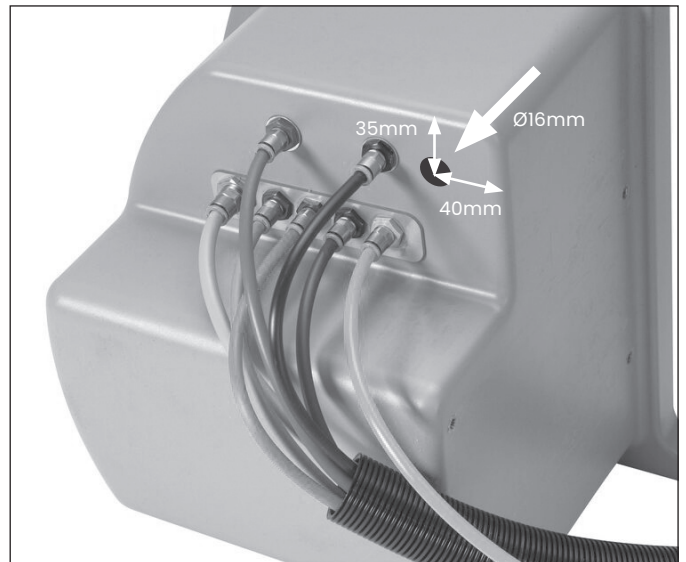

Picture 13

Cable length inside the switch cabinet shall not be less than 600mm. Connect the cable on the control circuit board on inlet X4 Spare (picture 14).

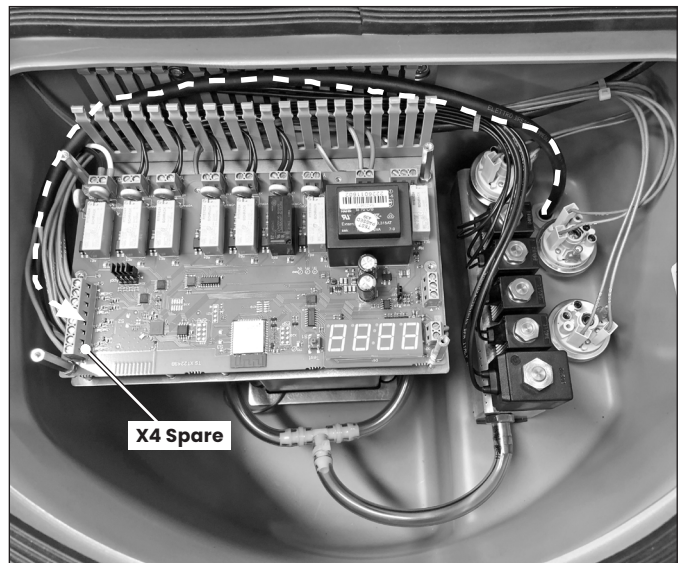

Picture 14

Backfilling the cavity

Continue backfilling to the soil surface. Backfilling shall be made with gravel or sand, and compact in 30cm layers. Shape the soil surface so that the surface waters are lead away from the pump chamber.

6. Pump chamber extension

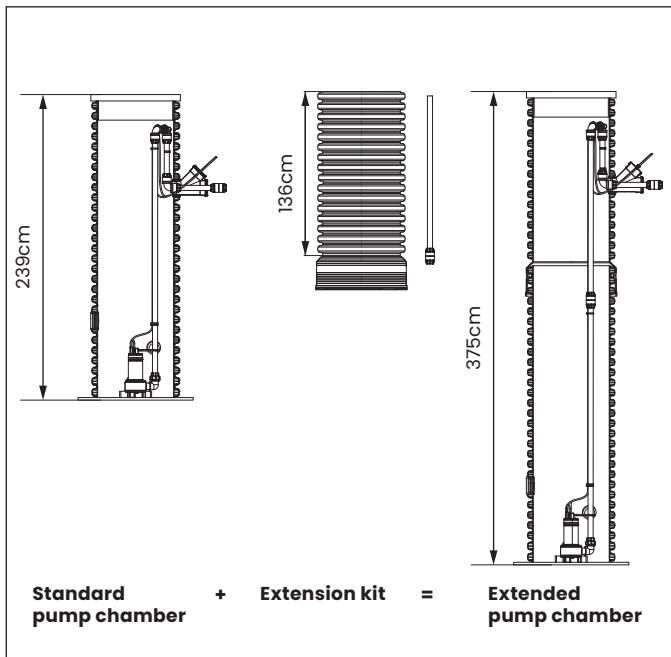

Picture 15 concept with standard height and extension

The pump chamber can be extended, with the help of Clean pump chamber extension kit. The maximum height of the extended chamber is 375 cm.

Product	Uponor No.
Clean Pump Chamber Extension Kit 1,4m	1140384

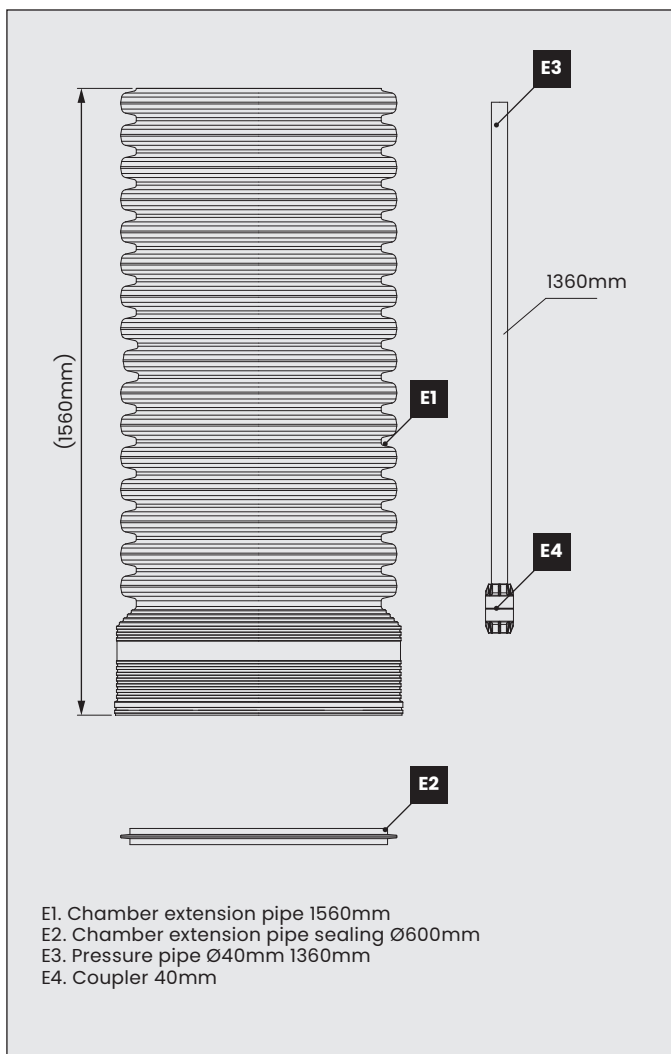

- E1. Chamber extension pipe 1560mm
- E2. Chamber extension pipe sealing Ø600mm
- E3. Pressure pipe Ø40mm 1360mm
- E4. Coupler 40mm

Picture 16 extension kit contents

Outlet in the extension pipe:

Extending the chamber: place the sealing (Ø600mm) on the uppermost groove of the chamber body. Lubricate the sealing, place the socket of the extension pipe on the chamber. Press the extension pipe so that the socket "bottoms".

Extending the pump module. Disconnect the cam-lock coupling from the top of the pump module B. Mount the double socket on the pressure pipe. Press the 40mm-extension-pipe on the double socket. Tighten the socket to both pipes. Mount the cam-lock coupling to the end of the extension pipe.

Note. If needed, the extended pump chamber can be shortened. **In that case, shorten the chamber body itself.** The pressure extension pipe shall be shortened with same measurement. Example: The wanted total height of the pump chamber is 3000mm. Then shorten both the chamber body itself and the pressure-extension-pipe with 500mm.

Make the outlet hole with a Ø138mm drill-saw. Continue installation as described on "Pump chamber installation".

7. Isolation if needed

Isolate pump chamber and pipes to treatment plant. Isolation thickness 50mm and width 1200mm round the pump chamber. Slanting outward from the pump chamber.

8. Service

Check pump chamber min. twice a year. Flush the pump and the level switches. Check the level switch function min. once a year. Lift it up and check the alarm from Info panel E034 or from switch cabinet. Make sure, that the power cables are fastened properly with a cable tie.

Service the pump. Make sure that the power is off before the maintenance. Loose the Camlock and power cables. Lift up the pump and clean it. Use protective gloves and glasses.

9. Pump technical data

Pump type: Lowara DOMO 7VX	
Power:	1-phase, 230V, 50Hz
Rated output:	0,55kW
Max flow:	19m ³ /h
Max head:	8m
Max particle size:	35mm

10. Contact info pump service

In pump malfunctions, contact the pump manufacturer's authorized service.

www.xylem.com/sv-se/

www.xylem.com/fi-fi/

www.xylem.com/nb-no/

www.uponor.com/sv-se

www.uponor.com/fi-fi

www.uponor.com/nb-no

Operation journal

Uponor Clean Pump Chamber

Date	Operator	Action

Uponor

Uponor Infra Oy

www.uponor.com/fi-fi

www.uponor.com/sv-se

www.uponor.com/nb-no

We reserve the right to make changes

1140386-EN-04-23_042023