

Uponor Thermatop S

EN Technical information

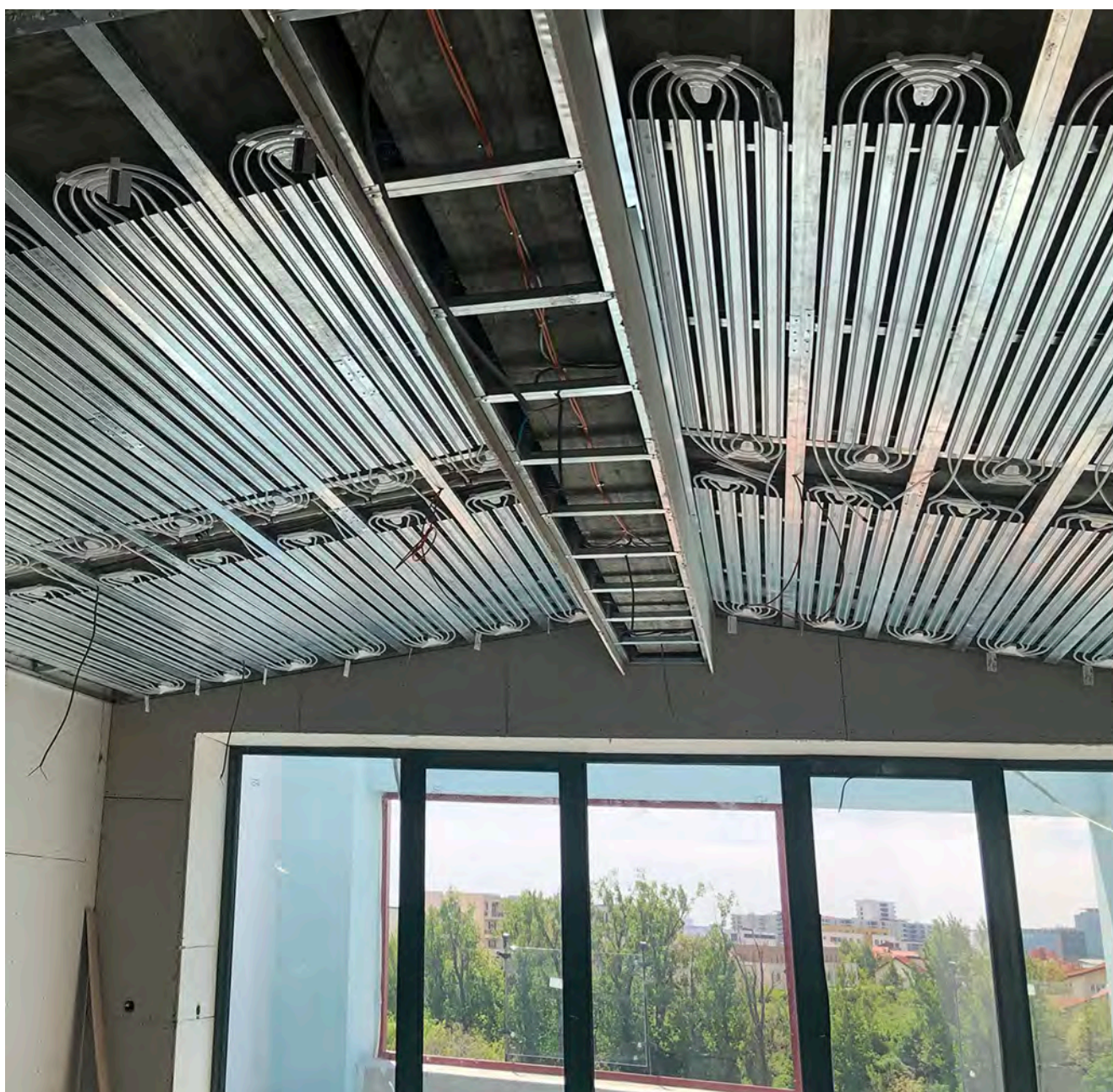
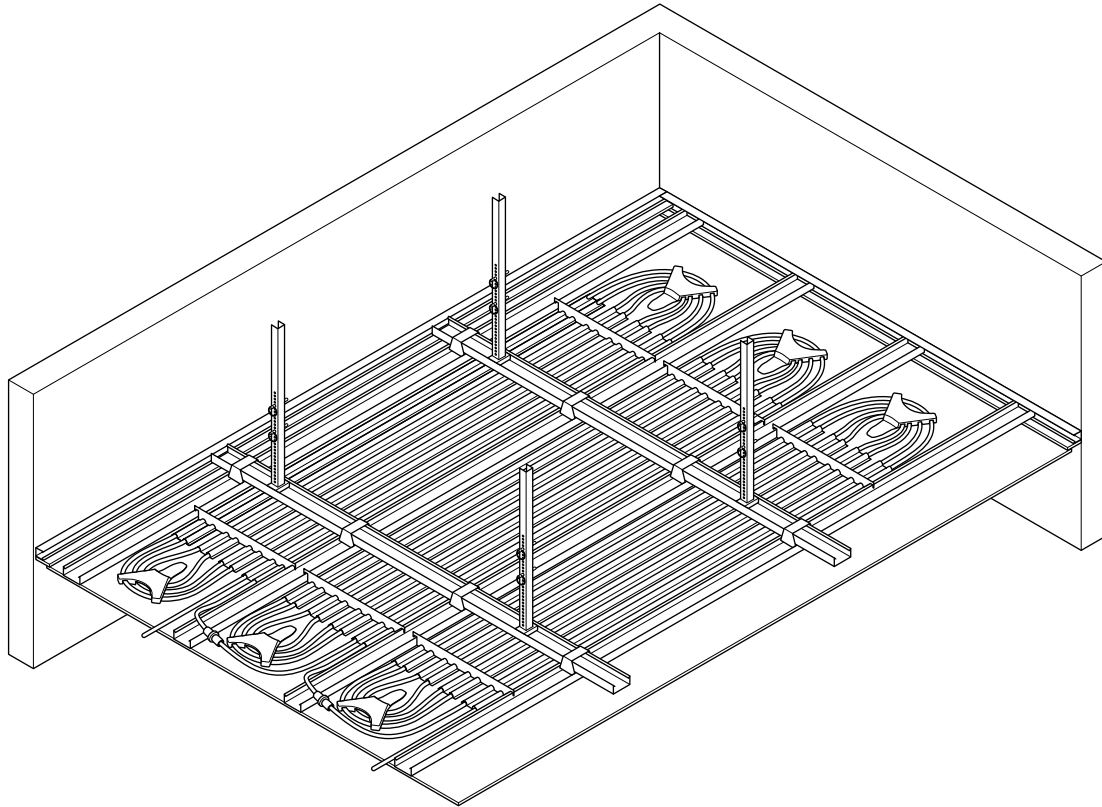

Table of contents

1	System description.....	3
1.1	Components.....	3
1.2	Construction.....	4
2	Planning/design.....	5
2.1	General information.....	5
2.2	Calculations.....	5
3	Technical data.....	9
3.1	Technical specifications.....	9

1 System description



SD0000192

Uponor Thermanop S is a radiant heating and cooling ceiling system that operates primarily according to the radiation principle, working inaudible and invisible inside seamless gypsum ceilings.

Uponor Thermanop S is ideal to efficiently create jointless, thermally active ceiling surfaces for heating and cooling applications in residential and office buildings. The design adapts to the requirements of flexible room design, the required heating and cooling capacity and complex room geometries with the largest possible active area. Uponor Thermanop S heating/cooling ceiling system enables a comfortable indoor climate. Lighting elements and other components, such as loudspeakers, sprinklers, etc. can be integrated into the ceiling as usual.

Quick and tool-free installation of the standardized panels by mounting into the CD profiles of the ceiling substructure. Jointings to distribution lines are made with Uponor Quick & Easy technology.

The panels consist of Uponor Comfort pipe 9.9 mm, pre-assembled with galvanized steel heat spreaders in different length. The joint spreaders enable fast snap mounting within the CD profiles of the ceiling substructure. Due to straight and even steel lamella with some flexibility in fixation, the installed panels will have full surface contact to gypsum cladding for best thermal performance.

Uponor Comfort Pipe 9,9 mm

Thermanop S includes the Uponor Comfort Pipe 9,9 mm, which is perfect for pipe layouts with close spacing and low installation height, with the best possible thermal and hydraulic efficiency. Uponor Comfort Pipe 9,9 mm is approved PE-Xa pipe class 4 as per EN ISO 15875, for maximum design temperature of 90°C and design pressure 6 bar at 70°C. It is approved oxygen diffusion resistance as per DIN 4726 .

1.1 Components

Uponor Thermanop S panel

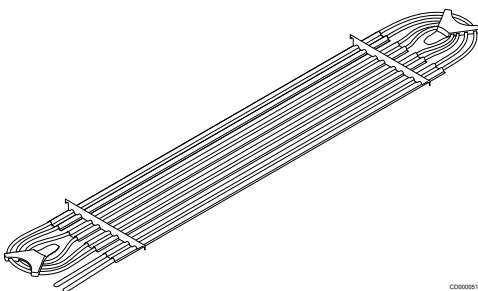

00000000

Uponor Q&E jointing technology

Uponor PE-Xa pipes have a unique characteristic, the so-called 'memory effect'. This results in a strong resilience that we use specifically for the Uponor Quick & Easy connection technology. When a Uponor PE-Xa pipe is expanded with a suitable tool, it strives to return within a short time back into its original form. We make use of this characteristic in the Quick & Easy connection technology. The pipe material serves as the seal material. The Uponor PE-Xa pipe connects with the Uponor Quick & Easy fitting. Jointing itself is very fast.

A 100% reliable connection between the fitting and the pipe is produced without making use of O-rings. Elaborate work such as welding or soldering is a thing of the past.

Uponor distribution pipe

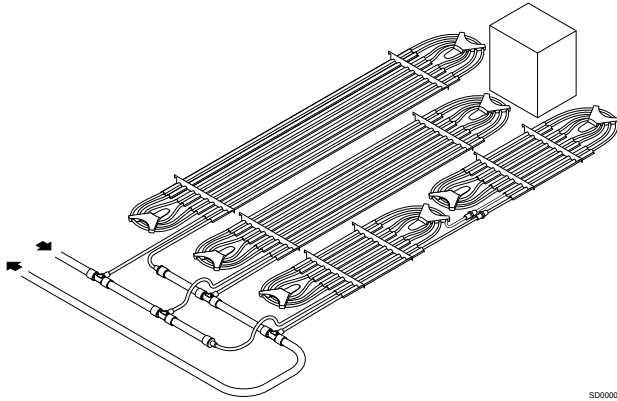

SD0000202

Due to wide portfolio to connect Thermatop S panels to a complete thermal active ceiling, Uponor recommends the installation with Uponor Comfort Pipe PLUS or Uponor Uni Pipe in our design services to enable full system.

1.2 Construction

Ceiling structure

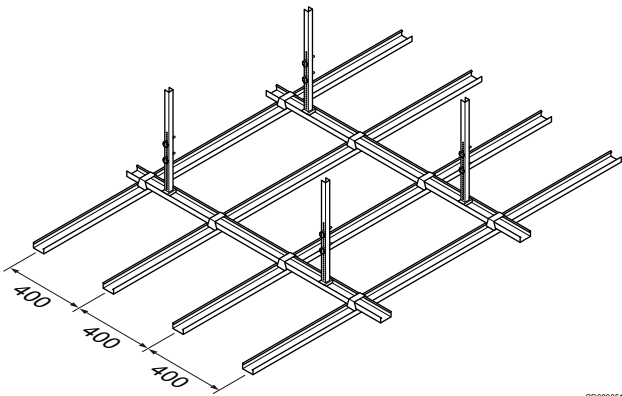

CD0000517

The Uponor Thermatop S heating and cooling panels are installed suspended within regular substructures (on site), between the CD 50 mm or CD 60 mm profiles of the ceiling structure. The planning/ mounting guidelines of the ceiling manufacturer are to keep.

Ceiling grid is 400 mm; the additional weight of Thermatop panels has to be considered with 5,5 kg/m² incl. water.

Ceiling cladding

Use standard gypsum panels 10 mm or “thermoboards” with improved heat conductivity. The cladding of the ceiling with gypsum boards (perforated or no perforated) has to follow dry build construction guidelines. Fixation by screws must not touch the pipe of the Uponor Thermatop S panel and need to follow standard dry installation distances for the given gypsum panel.

Surface treatment

Various options are possible for the finish of the visible surface, such as filling of the joints and terminations for different levels of quality or painting with opaque latex paint.

The use of acoustic plasters is possible but reduces the thermal capacity of the thermal active ceiling. The boards are to be primed before applying paint or other coating.

2 Planning/design

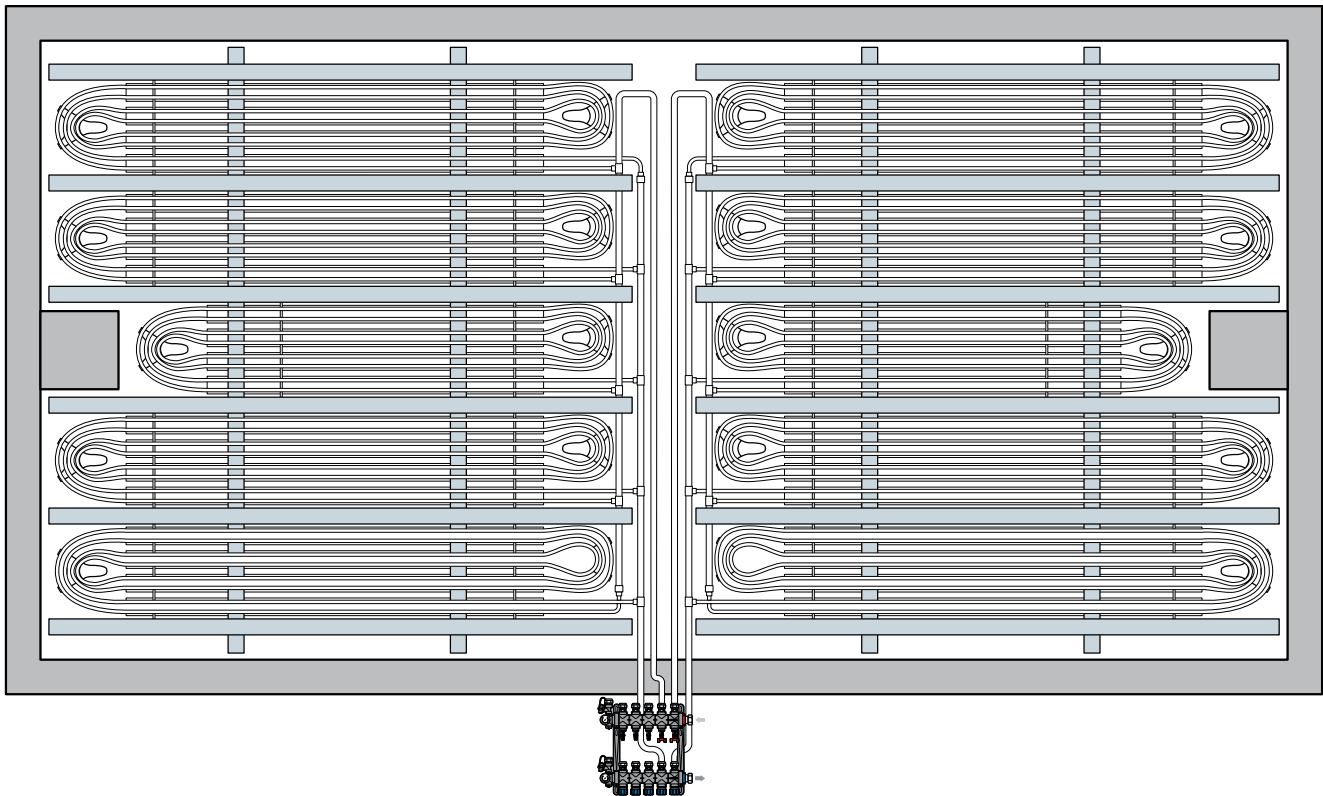

500000203

2.1 General information

Ceiling design and hydraulic connection

A ceiling plan is the basis for planning.

The quantities and dimensions of Uponor Thermatop S emitters follow the substructure of the suspended ceiling.

Changes in design or adaptations e.g. for lighting, air outlets, speakers etc. are to be planned prior to installation. The emitters are to be connected (watch max. loop lengths) in series.

The individual water circuits are connected through connection line directly or following the Tichelmann principle (please, note that the water circuits must be the same size) to a manifold or a floor pipework.

2.2 Calculations

Cooling and heating capacity

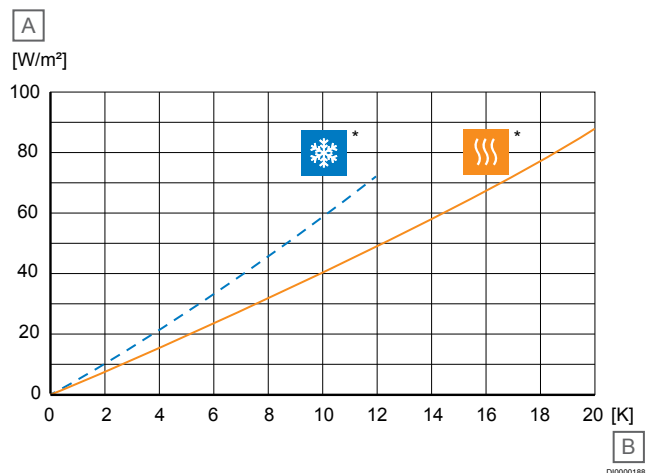

*) Nominal heating and cooling capacity of Uponor Thermatop S with 10 mm gypsum board (0,25 W/mK)

Item	Description
A	Surface area-related capacity [W/m ²]
B	Temperature difference [K] (mean water temperature to room temperature)

The heat transfer in closed, flat, thermal active ceilings according to DIN EN 14240:2004 and DIN EN 14037-5:2016 (closed test chamber, evenly distributed heat sources, adiabatic boundary surfaces) is

characterized largely by radiative heat exchange with the surrounding surfaces and heat sources as well as convection on the bottom side of the heating and cooling ceiling.

The conditions specified in the standard test represents the worst-case scenario. Under practical operating conditions, an even higher cooling capacity per m² is achieved. The tested cooling and heating performance values by standard test conditions can be read from diagram shown above. The capacity is read as a function of the

temperature difference between the mean water temperature and the room temperature. The performances in the diagram are based on the active surface of the panel in cooling mode. For heating mode the area includes the surface of profiles and panels.

- Cooling mode - active surface - acc. to DIN EN 14240:2004
- Heating mode - active surface - acc. to DIN EN 14037-5:2016

Active panel area

Description	Unit	Value					
Standard emitter length	mm	2000	2500	3000	3500	4000	4500
Pipe length	m	16,9	20,9	24,9	28,9	32,9	36,9
Active cooling area (calculative)*	m ²	0,68	0,85	1,02	1,19	1,36	1,53
Active heating area (calculative)*	m ²	0,8	1	1,2	1,4	1,6	1,8

*) Due to different ways of standard calculation methods, the calculated, active panel width, in accordance to DIN EN 14240:2004 (cooling) and DIN EN14037-5:2016 (heating), is:

- for cooling = 340 mm
- for heating = 400 mm

Thermal performance using different gypsum materials

Cooling ($\Delta t = 8$ K)

Description	Unit	Value					
Thickness	mm	10,0*	12,5	15,0	10,0	12,5	15,0
Thermal conductivity	W/mK	0,45*	0,45	0,45	0,23	0,23	0,23
Cooling capacity	W/m ²	46,0*	44,6	43,2	41,0	38,8	36,9

Heating ($\Delta t = 15$ K)

Description	Unit	Value					
Thickness	mm	10,0*	12,5	15,0	10,0	12,5	15,0
Thermal conductivity	W/mK	0,45*	0,45	0,45	0,23	0,23	0,23
Heating output	W/m ²	64,0*	62,0	60,0	57,0	54,0	51,0

*) Standard conditions; others calculated with finite elements methods

Calculation of maximum size of a water circuit (example)

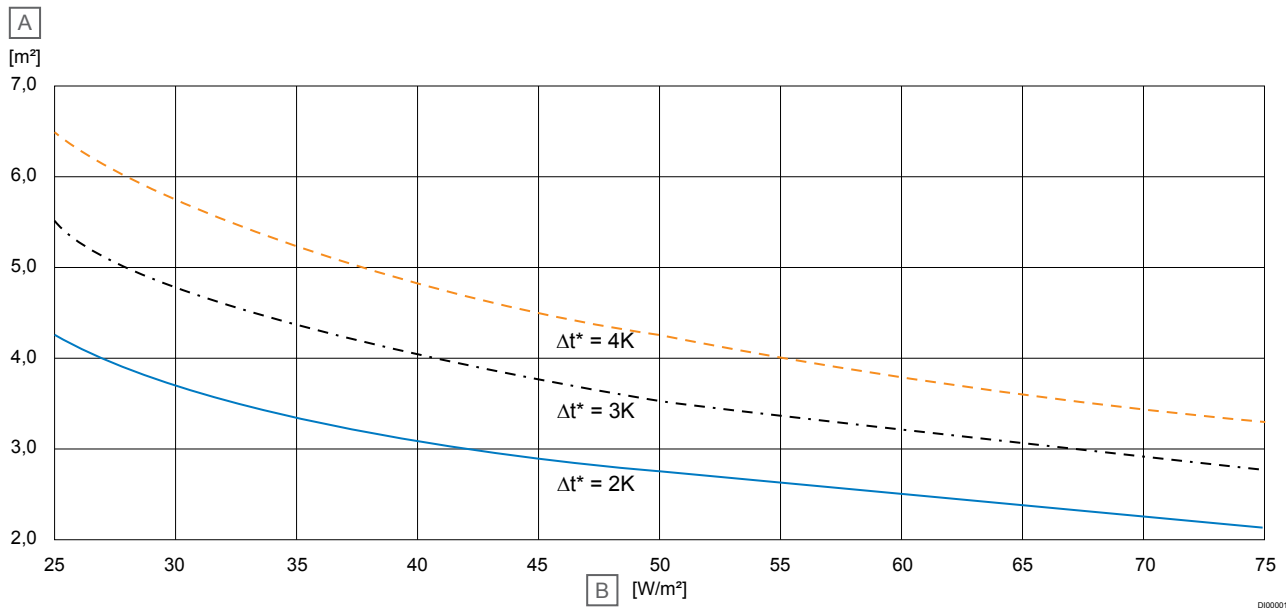

*) Δt = difference between supply and return temperature

Item	Description
A	Max. size of a water circuit [m²] with 25 kPa pressure drop per circuit
B	Cooling capacity [W/m²]

Example conditions

Description	Value
Room	Office, with gypsum board ceiling
Room temperature	26 °C
Cooling load	1000 W
Supply temperature	16 °C
Return temperature	18 °C
Linear temperature difference	9 K
Spread Δt	2 K

Design acc. to emitter area (m²)

Description	Value
Cooling capacity	52 W/m² (from heating/cooling capacity table for Uponor Thermatop S)
Max. size of a water circuit	2,7 m²
Requisite laid area	1000 W/52 W/m² = 19,3 m²
Selected emitter (active panel area for cooling)	3500 x 340 mm = 1,19 m²
Number of emitters	19,3 m²/1,19 m² = 16,2 pieces -> 17 pieces
Total area of emitters	17 x 1,19 m² = 20,23 m²
Total cooling capacity	20,23 m² x 52 W/m² = 1052 W
Total flow rate	$m = Q/c \times \Delta T$; $m = 1052 \text{ Watt} / 1,163 \text{ Wh/kg} \cdot \text{K} \times 2 \text{ K} = \mathbf{453 \text{ kg/h}}$ (l/h)

Calculation of pressure loss per water circuit (example)

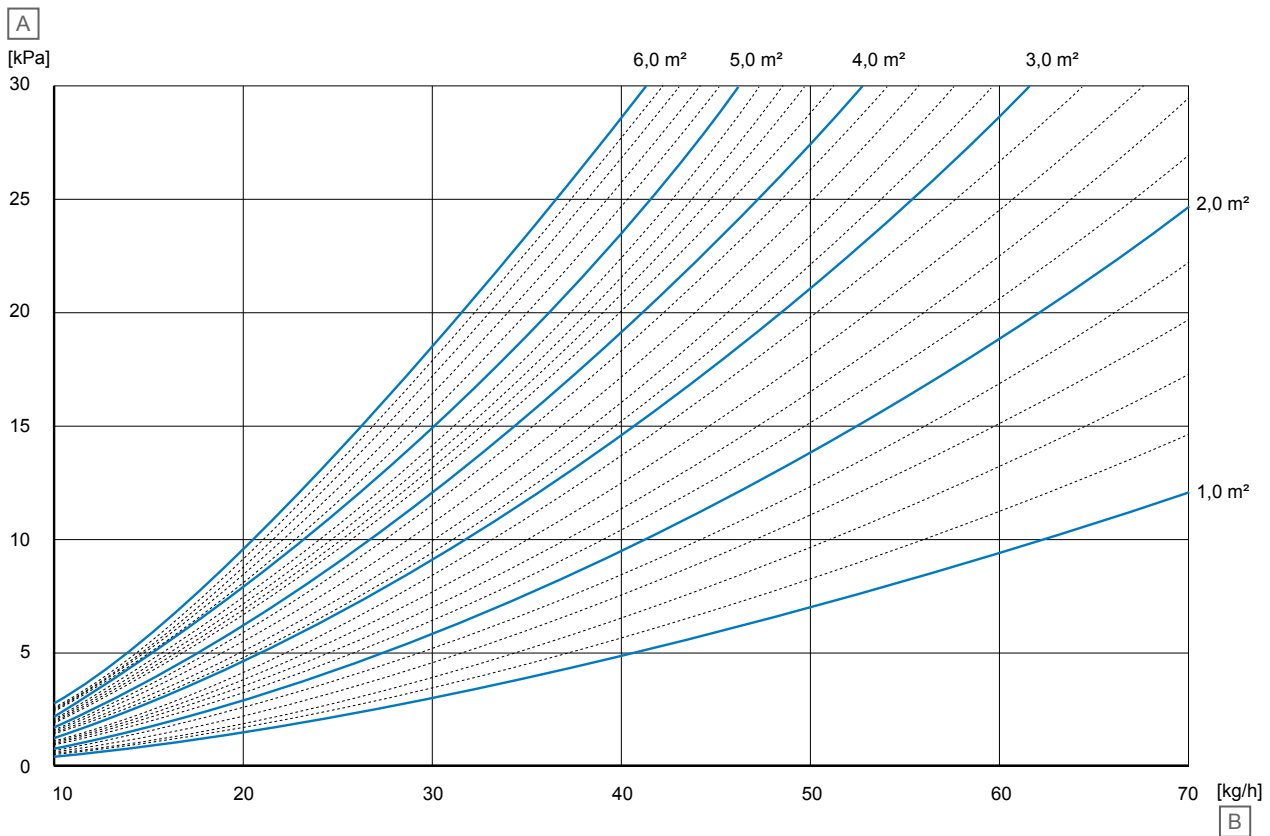

D0000190

Item	Description
A	Pressure loss per water circuit [kPa]
B	Flow rate [kg/h]

Design acc. to emitter area (m²)

Description	Value
Size of water circuit in m ²	2 x 1,19 m ² = 2,38 m ²
Water circuit cooling capacity	2,38 m ² x 52 W/m ² = 124 W
Water circuit flow rate	$m = 124 \text{ Watt} / 1,163 \text{ Wh/kg} \cdot \text{K} \times 2 \text{ K} =$ 53 kg/h
Water circuit pressure loss	18,2 kPa ; No connecting line (from chart above)

3 Technical data

3.1 Technical specifications

Description	Unit	Value
Ceiling cladding		Plaster/Thermoboard (standard board thickness; s = 10 mm)
Ceiling design		Non-perforated
Surfaces		Paint, wallpaper or plaster
Standard emitter length	mm	2000, 2500, 3000, 3500, 4000, 4500
Standard emitter width	mm	370 (please, see chapter "Active panel area" for active area dimensioning)
Standard emitter height	mm	36
Average pipe length/m ²	m	24,4
Embedded pipe		Uponor Comfort Pipe PE-Xa 9,9 x 1,1 mm
Emitter weight incl. water	kg/m ²	5,5
Cooling capacity in accordance with DIN EN 14240 : 2004		46 W/m ² at $\Delta\vartheta = 8$ K
Heating capacity based on DIN EN 14037-5 : 2016		64 W/m ² at $\Delta\vartheta = 15$ K
Recommended media temperature		Cooling water temperature: 16 °C; Heating water temperature: 35°C to max. 45°C
Operating conditions		Temperature heating mode max. +50 °C Condensation must be prevented!
Recommended pressure drop		max. 25 kPa per water circuit
Recommended total suspension height		≥ 120 mm (distance between the upper concrete ceiling and the visible side of the installed ceiling)

Uponor

Uponor GmbH

Industriestraße 56,
D-97437 Hassfurt, Germany

1122116 v1_08_2021_EN
Production: Uponor/SDE

Uponor reserves the right to make changes, without prior notification,
to the specification of incorporated components in line with its policy of
continuous improvement and development.



www.uponor.com