

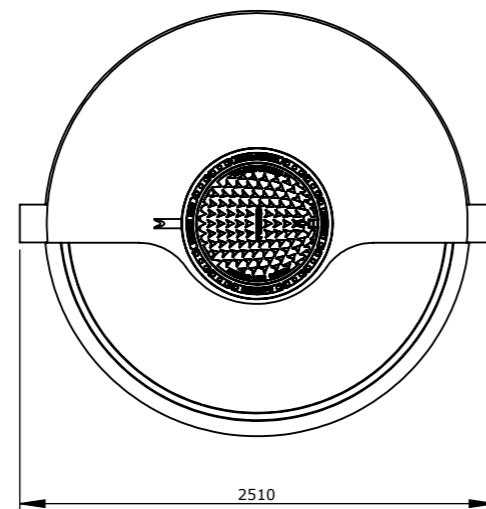

23

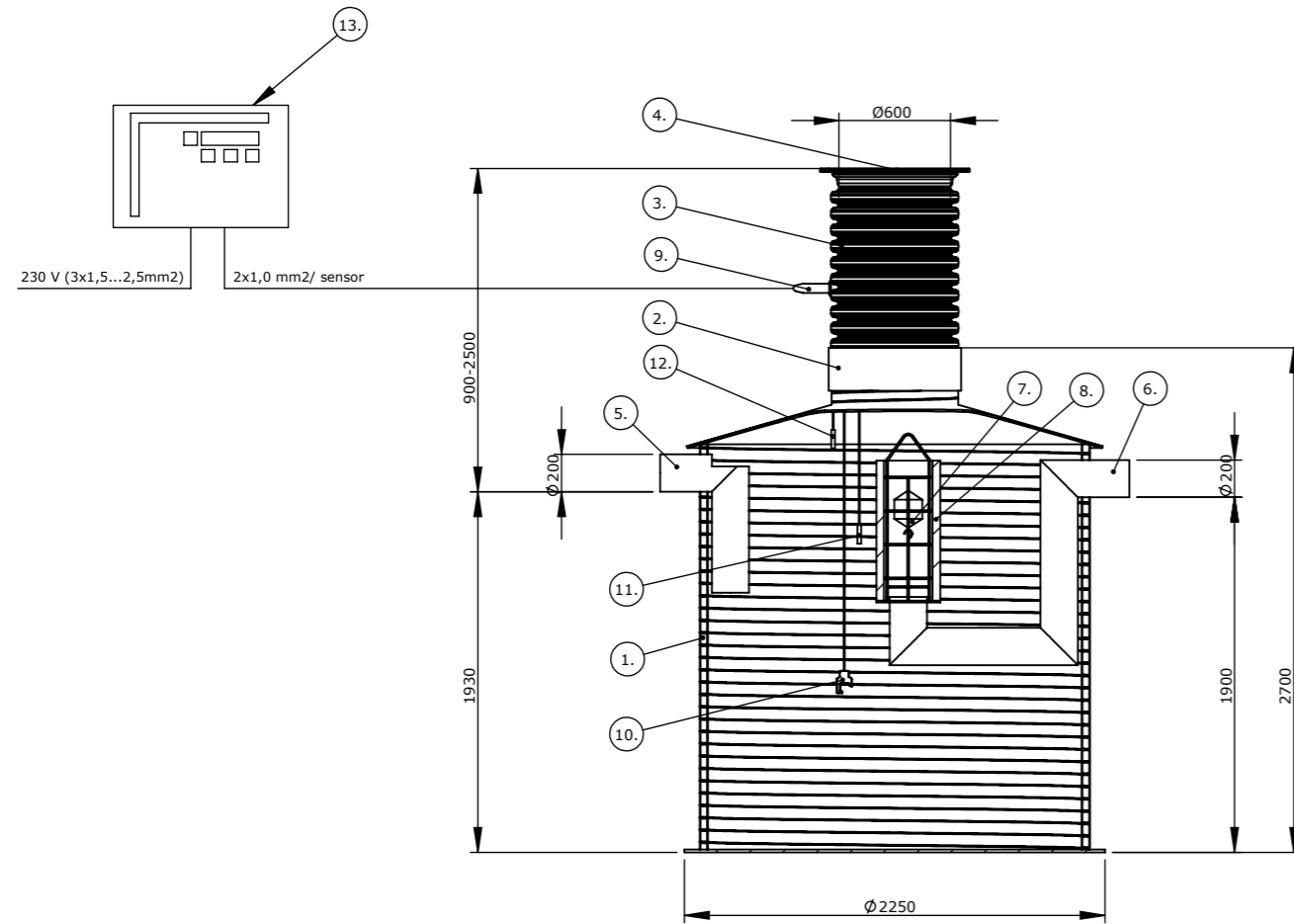

Oil separator-PE-20-4 class 1		NS	20
Effective volume		l	5969
Sludge storage volume		l	4000
Oil storage volume		l	785
Bottom-Inlet		mm	1930
Bottom-Outlet		mm	1900
1.	Tank PE, Ø-	mm	2250
2.	Riser connection	DN	600
3.	Riser	DN	600
4.	Cover	mm	600
5.	Inlet	mm	200
6.	Outlet	mm	200
7.	Automatic closure	mm	200
8.	Coalescence unit	NS	20
9.	Cable connection	DN	50
10.	Sludge level sensor*	pc.	
11.	Oil level sensor*	pc.	
12.	High level sensor*	pc.	
13.	Alarm control unit	pc.	

* Sensor installation height available in mounting instructions.

We reserve the right to changes.



City/Village	Block/Yard	Lot/Rno.	Notes from administrative authority	
Construction act			Drawing type	Number
Construction site: name and address			Qualifies	Scale
			Oil separator-PE-20-4 class 1	1:40
Designer: name, date and signature			Planning, work no. and drawing no.	Modification