

# Uponor Flowise: Pigging Chamber

## Technical Datasheet



uponor



# Uponor Flowise: Pigging Chamber



Pigging chamber allows easy access to the media pipe during flushing or cleaning.

A pigging chamber can be used as entry and exit point (design-specific).

Reduces preparation time, no need for excavation or cutting pipe.

Different 'plugs' can be used, such as foamed rubber or ice slurry.

## Pigging Chamber

Deposit and sediment build up in the potable water network over time. Pipe bursts also cause debris to accumulate in the pipes. Pigging is a method to scratch off and remove deposit from the pipe walls.

A plug, for example foamed rubber, is entered into the pipe and transported by water or air through the network. The plug and the debris are collected at a receiving point.

Ice-pigging is when ice slurry is used as the debris remover. The advantage is that no plug is used, and all water, ice and debris can be flushed out in a fire hydrant or similar point.

Application	Potable Water System
Material	PE100 (chamber body)
Dimension (ID) chamber body	1000 – 3000 mm
Colour	Black (outside) Light gray (inside)
Standards	EN 13598-2, EN 476
Approvals	Pipe design approved according NPM up to 3000 mm

# Properties and assortment

## System properties

Equipment is based on customer specifications. Available options listed in the *Uponor Flowise Polypigging/Spooling Chamber* type drawing.

Can be used as an entry point or an exit point, depending on the design.

Different pigging 'plugs' can be used.

Can be delivered as ready to install.

## Pigging Chamber

Uponor no 1140534



Uponor Flowise Pigging Chamber

# Uponor Flowise Polypiggin /Spooling chamber

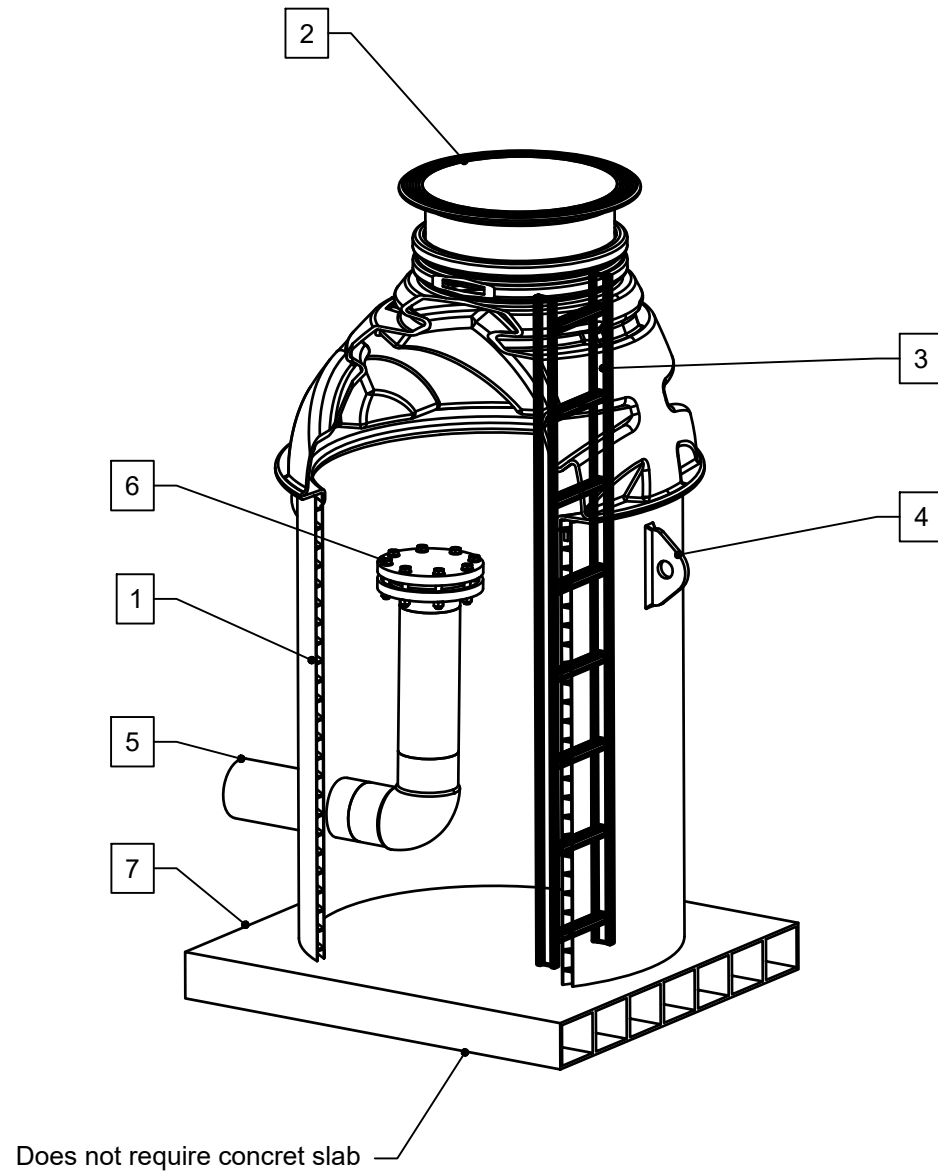
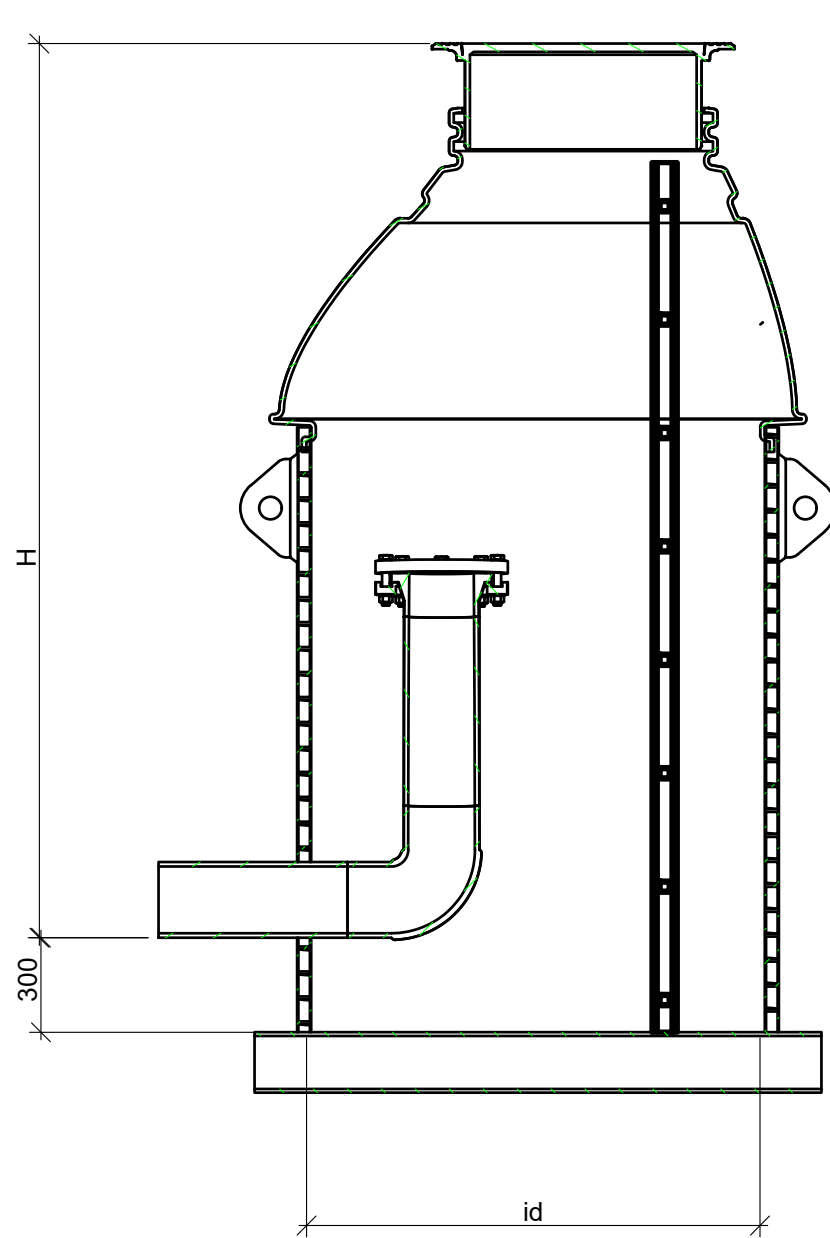

Polypigging / Spooling chamber			
Pos.	Description	Model/Size	Qty.
1	Chamber body PE100	Acc. selection	1
2	Chamber top	Acc. selection	1
3	Ladder	Acc. selection	0-1
4	Lifting yoke		2-4
5	Pressure pipe	Acc. selection	1
6	Blind flange	Acc. selection	1
7	Bottom, self anchoring		1

Selections	
Feature	Selection
Chamber body diameter	<input type="checkbox"/> 1000 <input type="checkbox"/> 1200 <input type="checkbox"/> 1250 <input type="checkbox"/> 1400 <input type="checkbox"/> 1600 <input type="checkbox"/> 2000 <input type="checkbox"/> 2400 <input type="checkbox"/> 3000 <input type="checkbox"/> Other: _____
Top solution	<input type="checkbox"/> A <input type="checkbox"/> B <input type="checkbox"/> C <input type="checkbox"/> D
Ladder*	<input type="checkbox"/> YES <input type="checkbox"/> NO
Groundwater level above invert	<input type="checkbox"/> YES <input type="checkbox"/> NO _____ m
Handrail*	<input type="checkbox"/> YES <input type="checkbox"/> NO
Pressure pipe invert from ground level	H= _____ mm
Pressure pipe diameter	D= _____ mm
Pressure gauge*	<input type="checkbox"/> YES <input type="checkbox"/> NO

Other:

<input type="checkbox"/> Ø 860/800 <input type="checkbox"/> Safety gridd	<b>A</b>	<input type="checkbox"/> 600X600 aluminium <input type="checkbox"/> 800X800 aluminium	<b>B</b>
<input type="checkbox"/> Ø630 cast iron 40tn <input type="checkbox"/>	<b>C</b>	<input type="checkbox"/> Ø630 cast iron 40tn <input type="checkbox"/> Ø800 cast iron 40tn	<b>D</b>

CASE NUMBER	DRAWN BY	HANDLED BY	
DATE	CONTACT PERSON		
13.02.2023	---		
CONTENT			
Air release chamber in-line			
SCALE		NUMBER	
1:20 (A3)		1140534-1	

WWW.UPONOR.COM

# Moving > Water

uponor

**Uponor Corporation**

Ilmalantori 4

00240 Helsinki

Finland

**T** +358 (0)20 129 211

**F** + 358 (0)20 129 2841

[www.uponor.com](http://www.uponor.com)