

OSA 3

Level alarm for oil separator

CONTENTS:

Functional description	2
Component parts	3
Spare parts	4
Safety regulations	5
Checklist	6
Installation	7
Commissioning	10
Operation	13
Maintenance	14
Programming	14
Troubleshooting	16
Technical data	18

Retain these instructions for future use.

Edition 1.8 - 23-02-03

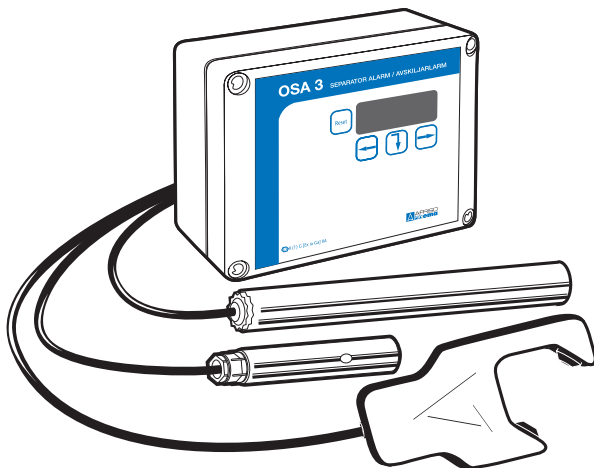

Afriso Ema AB

Kilvägen 2 • SE-232 37 Arlöv

Sweden

Phone: +46-(0)40-92 20 50

www.afriso.se

2460



Functional description

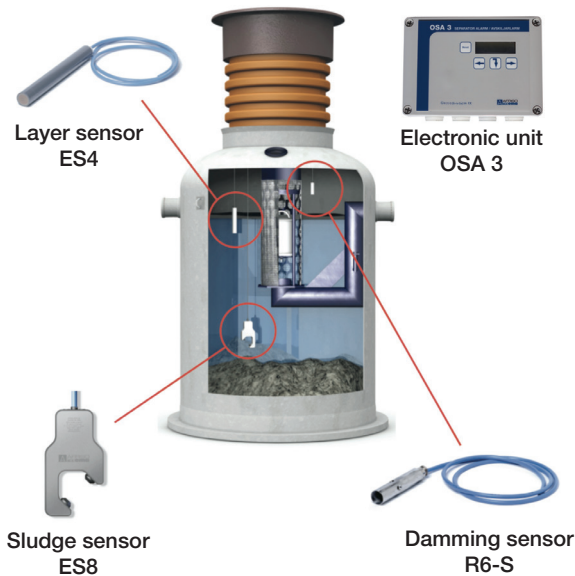

OSA 3 is an Intrinsically Safe (Ex) grease and oil separator alarm comprising of a central alarm control unit that can accept up to three independent alarm sensors from three separate alarm points.

The IP65 enclosure housing the alarm control is designed to be mounted onto a wall or a suitably flat surface.

Note: This central alarm unit must only be mounted in a “safe-area” and never installed in an area where there is a risk of an explosion.

- **ES4** Capacitance type layer (Ex) sensor for raising the alarm when the layer of oil or grease exceeds the alarm value.
- **ES8** Ultrasonic type sludge (Ex) sensor for raising the alarm when sand or particles in the separator exceed a predefined level.
- **R6-S** Thermistor type (Ex) damming sensor for indication of a high level.

OSA 3 is an Intrinsically Safe (Ex) central alarm control unit approved for use with the listed Ex sensors. The central alarm control unit has two individually programmable voltage free relay outputs (R1 and R2) that can be used to provide remote alarm monitoring or activation of secondary external alarms.

The central alarm control unit is programmable by navigation of the membrane keypad and displays the settings and alarms in a text format.

OSA 3 is supplied boxed and in the following variants:

1316	OSA 3 Level sensor
1318	OSA 3 Level and damming sensor
1319	OSA 3 Level, damming and sludge sensor
13347	OSA 3 Level and sludge sensor
13345	OSA 3 Sludge sensor

COMPONENT PARTS

OSA 3 level sensor
Art. No.: 1316

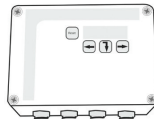

Central unit
OSA 3, 1 x



Level sensor ES4, 1 x

OSA 3 Level and damming alarm
Art. No.: 1318

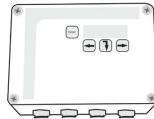

Central unit
OSA 3, 1 x



Level sensor ES4, 1 x

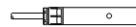

Damming sensor R6-S, 1 x

OSA 3
Level, damming and sludge alarm
Art. No.: 1319

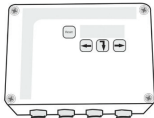

Central unit
OSA 3, 1 x



Level sensor ES4, 1 x



Damming sensor R6-S, 1 x



Sludge sensor ES8, 1 x

OSA 3 Level and sludge alarm
Art. No.: 13347

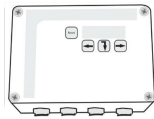

Central unit
OSA 3, 1 x



Level sensor ES4, 1 x



Sludge sensor ES8, 1 x

OSA 3 Slamgivare
Art. No.: 13345

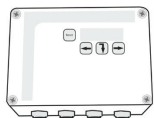

Central unit
OSA 3, 1 x



Sludge sensor ES8, 1 x

SPARE PARTS

INSTALLATION PARTS, SENSOR
Hook, grommet, cable tie, coupling sleeve
Art. No.: 1053



CENTRAL UNIT OSA 3
Electronic unit
Art. No.: 1310

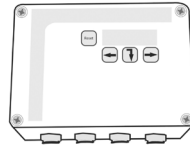

LEVEL SENSOR ES4, 5 meters
Capacitive sensor ES4. Emits alarm if thick layer of oil/grease in separator
Art. No.: 1147



LEVEL SENSOR ES4, 20 meters
Capacitive sensor ES4. Emits alarm if thick layer of oil/grease in separator
Art. No.: 1148

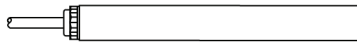

DAMMING SENSOR R6-S, 5 meters
Thermistor sensor. Emits alarm if high level in separator.
Art. No.: 990143



DAMMING SENSOR R6-S, 20 meters
Thermistor sensor. Emits alarm if high level in separator.
Art. No.: 990144



SLUDGE SENSOR ES8
Ultrasound sensor. Emits alarm if high sludge level in separator.
Art. No.: 1162



OPTIONS

Float
Float for level sensor ES4 where the surface is not constant
Art. No.: 1236





SMS-ALARM
GSM dialer for alarm transmission.
Art. No.: 1324





Safety regulations:

Safety symbols

SYMBOL	DESCRIPTION
	Critical warning, risk of injury
	Warning: risk of injury or damage to equipment
Note:	Attention required
	To note when there is a risk of explosion.

Regulations applicable to OSA 3

SYMBOL	DESCRIPTION
Note:	Read instructions before installation
	Installation may only be carried out by a qualified installation engineer
	The intrinsically safe circuit must not be earthed
	Observe regulatory requirements when connected in an EX-classified area

Checklist:

Before installation

- Do you have the knowledge necessary to carry out electrical installation? Note relevant EX regulations and regulatory requirements: EN60079-14 and EN60079-17 are particularly important.
- All pole switches should never be installed so as to prevent the disconnection of the alarm function.
- Extension cables to sensor, 2 x 1.5 mm² or 6 x 1.0 mm², max. 200 metres
- Remember to check regulations and installation instructions for your specific system

After installation

- Check the connection of the electronic unit, cable area and use of poles
- Flat strip for cover fitted on electronic unit, and cover closed
- Check installation position of sensor as per the separator manufacturer's recommendations
- Make sure the separator is filled with water as per the manufacturer's recommendation before carrying out a sensor function control
- Switch on the power and check sensor signals
- Carry out a function control as shown in the commissioning instructions

Important information

Note that the unit's intrinsically safe sensor outputs on terminal block K3 (1,2,3,G) are galvanically isolated from earth.

This user manual constitutes the basis for certification governing protection in a potentially explosive atmosphere for level alarms of type OSA 3 in accordance with certificate SP11 ATEX3644X. It does not extend to certification of other products mentioned in the user manual. Specific connection examples contained in the user manual are not covered by certification in accordance with SP11 ATEX3644X.

It is not permitted to repair the electronic unit in the event of a fault. The unit must either be replaced or sent to Afriso Ema AB for fault diagnostics/examination.

The unit comes supplied with a cable gland or a cable grommet. Only a cable of suitable outer diameter may be used in accordance with the installation regulations. Unused connections must be suitably plugged.

Installation

Wiring the system using multi-core cables

Note: Read the installation instructions



Installation should only be carried out by a suitably qualified Installation Engineer.



The intrinsically safe circuit must not be earthed

When connecting more than 1 sensor it is recommended that a junction box is used. If a junction box is not used all cable joints should be sealed using heat shrink tubing. When connecting an ES8 sludge sensor an external junction box should be used that allows the shielded cable to be grounded to earth.

When making connections between the central control unit and a junction box this should be interconnected using a multi-core cable (6-core 1.0mm²) with connections made as shown in the following diagram.

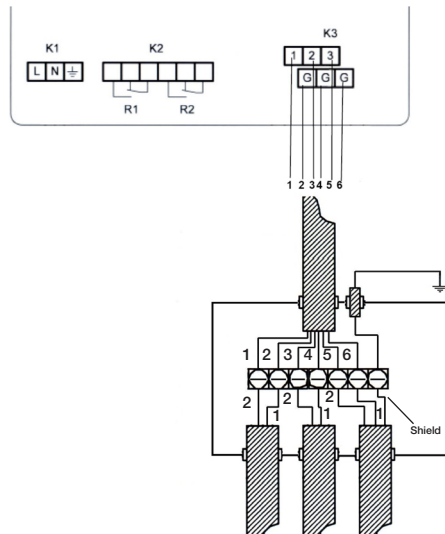

Terminals

K1: 230 VAC, 4 VA

K2: R1 Voltage free relay output (Symbols on the circuit board are indicated in the alarm condition)

K2: R2 Voltage free relay output (Symbols on the circuit board are indicated in the alarm condition)

K4: Terminal contact for membrane keypad ribbon cable (not shown)

K3: 1-G Capacitive sensor ES4

K3: 2-G Thermal sensor R6-S

K3: 3-G Sludge sensor ES8

Recommended cable

Power supply: 3 x 1.5 mm²

Multi-core cable to junction box: 6 x 1 mm²

Wiring the system using individual cables



When fitting an ultrasonic sludge sensor a junction box should always be used that allows the equalisation of the earth potential outside of the alarm control unit.

When connecting more than 1 sensor it is recommended that a junction box is used. If a junction box is not used all cable joints should be sealed using heat shrink tubing. When connecting an ES8 sludge sensor an external junction box should be used that allows the shielded cable to be grounded to earth.

Terminals

- K1: 230 VAC, 4 VA
- K2: R1 Voltage free relay output (Symbols on the circuit board are indicated in the alarm condition)
- K2: R2 Voltage free relay output (Symbols on the circuit board are indicated in the alarm condition)
- K4: Terminal contact for membrane keypad ribbon cable (not shown)
- K3: 1-G Capacitive sensor ES4
- K3: 2-G Thermal sensor R6-S
- K3: 3-G Sludge sensor ES8

Recommended cable

Power supply: 3 x 1.5 mm²
 Separate cable for sensor ES4 and R6-S: 2 x 1 mm²
 Separate cable for sensor ES8: 3 x 1 mm² or 2 x 1 mm² with shielding

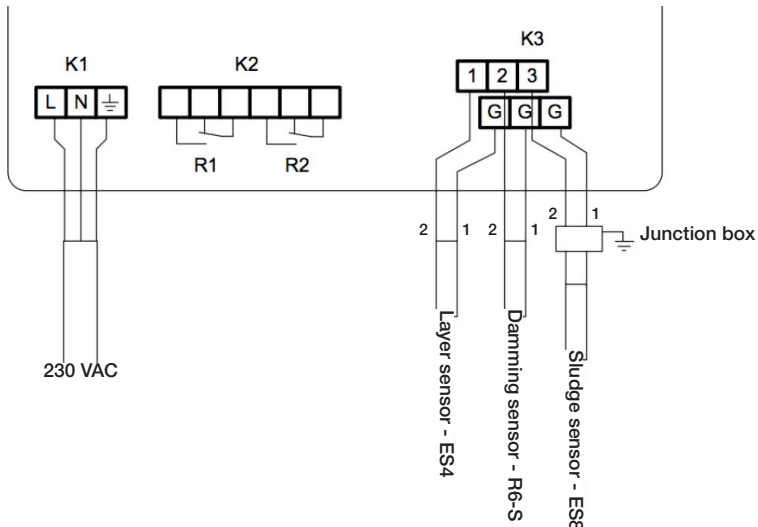

Assembly



The electronic must not be positioned in any area where there is a risk of explosion



All cables laid within the hazardous area zones should be mechanically protected.

OSA 3 should be wall mounted in an appropriate safe-area. It is always recommended that the power supply should be connected so as to prevent accidental isolation of the system that may result in separator alarm conditions being inactive and missed. of fitting. The exact appearance of separator types will vary from manufacturer to manufacturer. Check with your separator manufacturer for more details.



The following recommendations apply:

Level sensor ES4 is fitted so that its underside H^* is fixed approx. 100-500 mm below the static water level. The precise installation depth H^* below the static water level is specified in the separator manual. The underside of the level sensor must be in water so as NOT to trigger an alarm, see the illustration below.

Damming sensor R6-S is fitted approx. 100 mm above the top of the separator's intake pipe. The damming sensor must be in air so as NOT to trigger an alarm, see the illustration below.

Sludge sensor ES8 is fitted so that its underside is located at the recommended emptying height for sludge, specified in the separator manual.

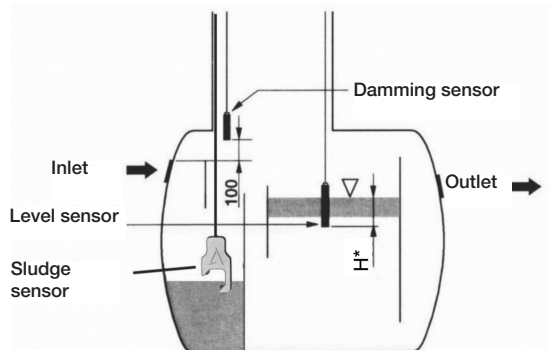







H^* : the precise installation depth is specified in the separator manual.

Commissioning

Note: For the oil/petrol/grease warning device to trigger an alarm, a marked layer must form between the water and the oil/grease/petrol. The equipment will not work in an emulsion or where grease or oil has been dissolved by chemicals

Operation on startup

The following buttons can be found on the unit:  = arrow left,  = arrow right,  = arrow down and reset to reset.

- The “” and “” buttons are used to increase and decrease input values in the display
- “” down is used to acknowledge the input values and to move forwards through input menus

Backlight in display:

Flashes when an alarm or an error message has been triggered. Use the reset button to acknowledge alarms.

Buzzer:

A built-in buzzer makes a noise when an alarm or an error message has been triggered. The buzzer sound is repeated automatically after 20 hours if R1 is not set for an acknowledgeable function.

Checks when starting the electronic unit

Check that all connections and installation are completed correctly before connecting to a power supply.

- Switch on the power supply to the electronic unit



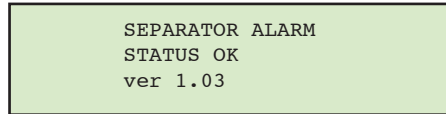

This screen is displayed for approx. 15 seconds, after which the current program version can be viewed on screen.

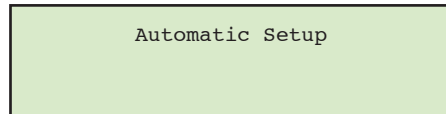

The automatic setup function then commences. The first step involves setting the date and time, then the unit carries out a check of sensor inputs on startup and registers automatically connected sensors



• Set date/time

Use the arrow keys on the electronic unit to move the cursor and set the date and time. The  key moves from the first digit in the date and forwards every time it is pressed. To reduce a value, press , and to increase a value, press . When you have finished, hold down  for 3 sec and the unit will switch to scanning sensors.

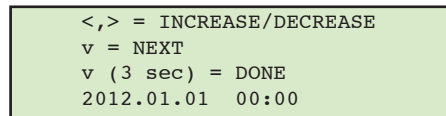

- Scanning of sensors

The unit now starts automatically scanning the sensor inputs, after which the following screens are shown. If the unit finds a correctly connected sensor, it automatically continues searching on the next channel, i.e. 1, 2 and 3.

```

searching for sensor
      1
  
```

- Sensor not detected

If an input does not have a connected sensor, this can be confirmed in this routine. The key is used to approve the response marked **-YES-**.

```

searching for sensor
      1
Not connected. OK ?
-YES-                No
  
```

If a sensor is not detected at an input despite the sensor being connected, the same message as the one shown above will appear on screen, and in this instance it is necessary to correct any incorrect connection (see Troubleshooting).

```

SEPARATOR ALARM
STATUS OK
2012.01.01  16:00
  
```

When automatic startup is complete and all sensors have been detected, the unit is ready to use and the following appears in the display.

Sensor function control

Before any tests are made activate the service mode of the unit. This must be done in order to detect alarms without filtering/delay. Especially the sludge probe can not be tested properly if the service mode is not activated. In the main menu press the + RESET key at the same time for 3 seconds. The following screen will appear:

```

> SERVICE
DATE-TIME
INPUTS
RELAY OUTPUTS
  
```

Activate the service mode by pressing for 3 seconds. The unit will now show a number on the screen indicating which probe is being scanned. The unit remains in service mode for 30 minutes and returns automatically into normal mode.

All connected sensors should be tested after installation. The following must be done in order to test the various sensors:

- Capacitive layer sensor type ES4 is lifted up out of the water in order to trigger an alarm.
- Damming sensor type R6-S is dipped in water in order to trigger an alarm.
- Sludge sensor type ES8 is lifted up into air or pushed into sand/sludge in order to trigger an alarm.

Note that it may take up to approx. 60 seconds to trigger an alarm. This is because the unit requires a number of scans in line with the alarm status of the sensors in order to trigger an alarm. This is done to minimise the risk of false alarms when the alarm level is close to the sensor.

- Testing of level sensor ES4

Lift the level sensor up into the air and wait. The following screen should be displayed within approx. 60 sec.

```

Level alarm act.
Press [Reset] to
acknowledge sound
  
```

Press the reset button, the following should then be displayed.

Level alarm act.

When this has been displayed, lower the sensor into the separator again. The sensor should then return to “Normal operation screen” after up to 60 seconds.

• **Testing of damming sensor R6-S**

Lower the damming sensor into liquid, e.g. water, and wait. The following screen should be displayed within approx. 60 sec.

Press the reset button, the following should then be displayed.

High level alarm act.
press [Reset] to
acknowledge sound

High level alarm act.

When this has been displayed, remove the sensor from the water and wait for up to 2 minutes. The unit should then return to “Normal operation screen”.

• **Testing of sludge sensor ES8**

Lift the sludge sensor up into the air and wait. The following screen should be displayed within approx. 60 sec. (Note. Service mode need to be activated. See page 12).

Sludge alarm act.
press [Reset] to
acknowledge sound

Press the reset button, the following should then be displayed.

Sludge alarm act.

When this has been displayed, suspend the sensor in the water again and wait for up to 2 minutes. The unit should then return to “Normal operation screen”.

Once all tests have been carried out, the unit is ready to use.

Operation

Normal operation

If after commissioning the functional controls no alarms appear on the display the level alarm is now ready to use. No special operation is required other than to ensure the power supply to the alarm is continually maintained in order for the sensors to detect an alarm condition. Under normal operation, the text **STATUS OK** appears in the display.

```
SEPARATOR ALARM
STATUS OK
2012.01.01 16:00
```

In the event of an alarm

In the event of an alarm, text appears in the display indicating which sensor has been actuated

Layer alarm: LAYER ALARM appears in the display and the buzzer sounds.

```
Level alarm act.
press [Reset] to
acknowledge sound
```

Action: This normally means it is time to order emptying of the separator.

High level alarm: HIGH LEVEL ALARM appears in the display and the buzzer sounds.

Action: This is a **critical alarm** and means that the shut-off valve in the separator has been closed or there is a blockage in the outlet to the tank. Check the instructions from the separator manufacturer to find out what action is recommended.

```
High level alarm act.
press [Reset] to
acknowledge sound
```

Sludge alarm: SLUDGE ALARM appears in the display and the buzzer sounds.

Action: This normally means that the sludge layer in the tank is too thick, this normally results in impairment of the efficiency of the separator. Separator emptying should be ordered.

```
Sludge alarm act.
press [Reset] to
acknowledge sound
```

Sensor error: In the event of a problem with a sensor connection, SENSOR ERROR appears in the display along with an indication of which sensor has triggered the alarm, and the buzzer sounds. Check the sensor and its connection (see the Troubleshooting section).

```
Sensor err on
input 3 (sludge)
see manual for
action [Reset]=mute
```

Maintenance

The function of the separator alarm must be tested as described in SS-EN 1825 and SS-EN 858.

For more details, see the operation and maintenance instructions for the separator. The sensors may need to be periodically cleaned or wiped so as to prevent excessive deposits building up that may cause the triggering of false alarms.

PROGRAMMING FUNCTIONS IN OSA 3 -Ver 1.03 18-02-16

This manual is intended for authorised service personnel only.
The flow chart below shows all the possible functions which can be accessed via the buttons on the unit.

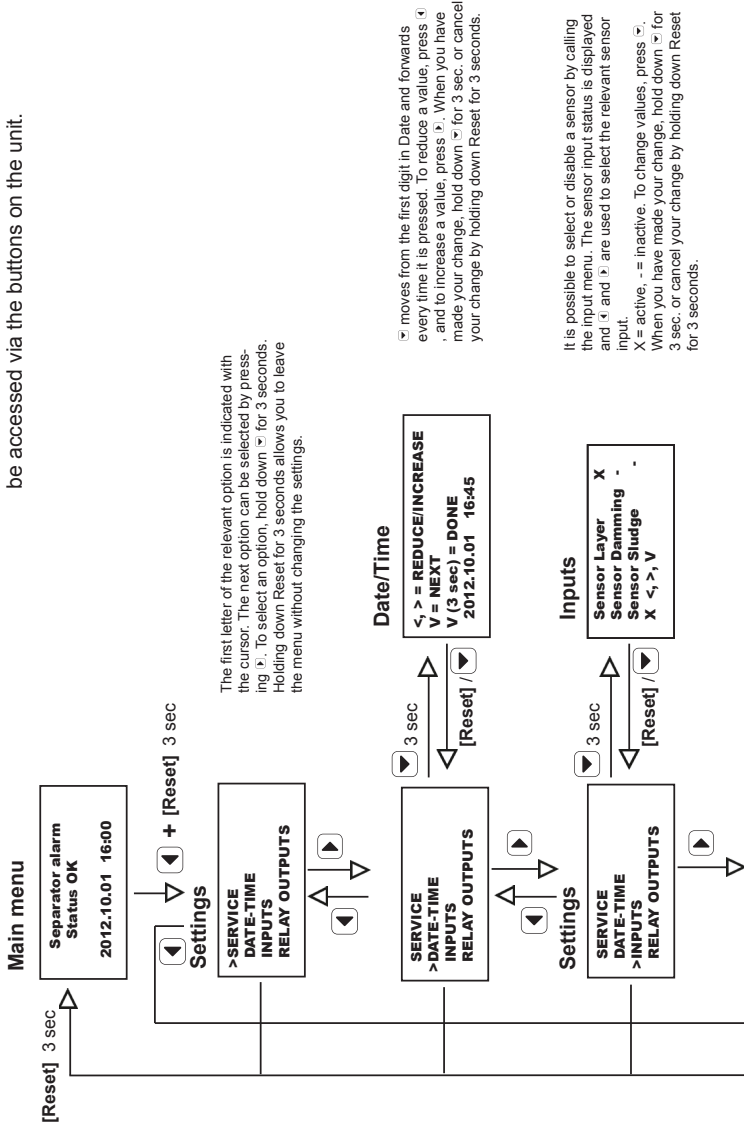

The first letter of the relevant option is indicated with the cursor. The next option can be selected by pressing **<**. To select an option, hold down **>** for 3 seconds. Holding down Reset for 3 seconds allows you to leave the menu without changing the settings.

< moves from the first digit in Date and forwards every time it is pressed. To reduce a value, press **<** and to increase a value, press **>**. When you have made your change, hold down **>** for 3 sec. or cancel your change by holding down Reset for 3 seconds.

It is possible to select or disable a sensor by calling the input menu. The sensor input status is displayed and **<** and **>** are used to select the relevant sensor input.
X = active, - = inactive. To change values, press **<**. When you have made your change, hold down **>** for 3 sec. or cancel your change by holding down Reset for 3 seconds.

Possible settings are for R1 and R2. Act = Acknowledgeable/Non-acknowledgeable, ACT = Selection of which input(s) enables (enable) the relay output. 2 = moves to the right between the various options. X = active, - = inactive. To change values, press ▾. When you have made your change, hold down ⇨ for 3 sec. or cancel your change by holding down Reset for 3 seconds.

Calling the settings menu allows you to display Languages. Selectable languages, and you can select a language using the ⬅ and ➡ keys. To make your choice, the v key has to be held down for at least 3 sec., or you can cancel your change by holding down Reset for 3 seconds.

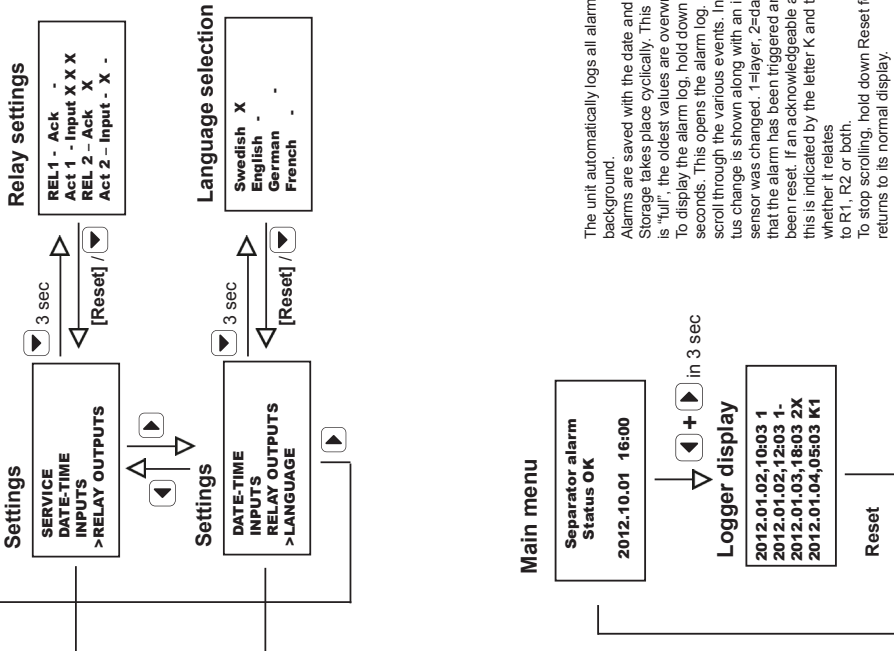

The unit automatically logs all alarm changes with date/time in the background.

Alarms are saved with the date and time of each status change. Storage takes place cyclically. This means that when the memory is "full", the oldest values are overwritten with new ones.

To display the alarm log, hold down ⬅ and ➡ together for 3 seconds. This opens the alarm log. Pressing ⬅ or ➡ allows you to scroll through the various events. In the example below, each status change is shown along with an indication of the time and which sensor was changed. 1=layer, 2=damming, 3=sludge. X means that the alarm has been triggered and - means that the alarm has been reset. If an acknowledgeable alarm has been acknowledged, this is indicated by the letter K and the relevant digit to indicate whether it relates

to R1, R2 or both

To stop scrolling, hold down Reset for 3 seconds. The unit then returns to its normal display.

Troubleshooting

Note: If an input did not have a sensor installed when the system was installed, this will not be scanned. To activate an inactive output, see the Maintenance section.

Note: Sensors are activated in a sequence: Sensor 1 (level sensor ES4) active in 4 sec -> sensor 2 (thermistor sensor R6-S) active in 45 sec -> sensor 3 (sludge sensor ES8) active in 4 sec. This sequence is repeated continuously.

Checks when alarms appear in the display

Problem	Check	Cause/action
Layer alarm		
"Level alarm act." alarm appears in the display	Check the thickness of the oil/grease layer	Order emptying
"Sensor err on input 1 (level)" alarm appears in the display	Measure voltage at sensor	Error in sensor circuit to sensor (e.g. cable failure/short-circuit)
Damming alarm		
"High level alarm act." alarm	Blockage at outlet to separator (critical alarm)	Clear blockage or find out cause
"Sensor err on input 2 (high level)" alarm appears in the display	Measure voltage at sensor	Error in sensor circuit to sensor (e.g. cable failure/short-circuit)
Sludge alarm		
"Sludge alarm act." alarm	The sludge level has reached a set alarm level (normal alarm)	This normally means that the sludge layer in the tank is too great, this normally results in impairment of the efficiency of the separator. Separator emptying should be ordered.
"Sensor err on input 3 (sludge)" alarm appears in the display	Measure voltage at sensor	Error in sensor circuit to sensor (e.g. cable failure/short-circuit)

Voltage measurements of the sensors

In the event of a fault occurring in any of the sensor circuits an error message will be displayed on OSA 3 indicating which sensor output is detecting an error. The output voltage to the sensor in question can be measured in order to check what is wrong.

Sensors are scanned in the following sequence, and sensors can only be checked when they are active: Sensor 1 (layer sensor ES4) active in 4 sec -> sensor 2 (thermistor sensor R6-S) active in 45 sec -> sensor 3 (sludge sensor ES8) active in 4 sec. This sequence is repeated continuously.

When the OSA 3 alarm unit is connected to intrinsically safe circuits that enter an area with a potentially explosive atmosphere, extreme care should be taken when performing fault diagnostics on a live alarm unit. The only live parts in the unit that may be touched (with a tool or instrument) are connections on intrinsically safe terminal block K3. Only measuring instruments that do not have a detrimental effect on the intrinsi-

cally safe characteristics may be used. EN 60079-17 must be adhered to during fault diagnostics/maintenance.

Note: Measure the voltage and use a multimeter showing decimals in order to measure the difference in voltage.

The illustration below shows an example for connection for troubleshooting of sensor 1

Terminals 1, 2 and 3 and + feed to sensor and Terminal G is the relevant output feed.

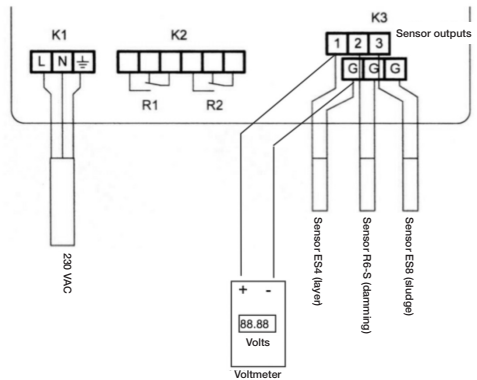

Table for check measurement of sensors

Sensor	Measurement	Error/status	Action
1 Layer sensor	19 V	Sensor not connected or cable failure	Connect sensor/troubleshoot cable
	19 V	Sensor is connected incorrectly	Check polarisation
	0.2 V	Sensor circuit short-circuited	Check sensor circuit
	13.2 V	Sensor in air or oil/grease (alarm status)	Empty separator, or if sensor
	15.3 V	Sensor in water (normal operation)	
2 Damming sensor	19 V	Sensor not connected or cable failure	Connect sensor/troubleshoot cable
	0.2 V	Sensor circuit short-circuited	Check sensor circuit
	7.5 - 12.3 V	Sensor in fluid (alarm status)	Empty/check separator
	14.2 - 16.5 V	Sensor in air (normal operation)	
3 Sludge sensor	19 V	Sensor not connected or cable failure	Connect sensor/troubleshoot cable
	19 V	Sensor connected incorrectly	Check polarisation
	0.2 V	Sensor circuit short-circuited	Check sensor circuit
	13.1 V	Sensor in air or sludge (alarm status)	Empty/check separator
	15.3 V	Sensor in water (normal operation)	

When the sensor output is inactive, the voltage at the output is 0 volts.

TECHNICAL DATA

Central element
 OSA 3

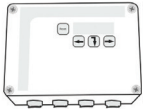

ATEX standard	EN IEC 60079-0 (2018) EN 60079-11 (2012)
Certificate number	SP 11ATEX3644X
Intrinsically safe design	II (1) G [Ex ia Ga] IIA
Intrinsically safe circuit is galvanically isolated from earth.	
Intrinsically safe circuit sensor	C_0 : 3.0 μ F, L_0 : 7.0 mH I_0 : 181 mA, U_0 : 24.8 V P_0 : 1.12 W
Operating voltage	230 V, 50 Hz
Relay outputs, contact data	Um 250 V, Im 4A, max 100 VA (AC)
Ambient temperature, electronics	± 0 - $+40^\circ$ C
Enclosure class	IP 65

Note: The above intrinsically safe parameters (C_0 and L_0) apply under the following conditions:

1. The combined concentrated inductance (Li) and capacitance (Ci) of the external intrinsically safe circuit does not exceed 1% of the above values or
2. Inductance and capacitance are distributed as in a cable or
3. The external intrinsically safe circuit does not contain either concentrated inductance on its own or concentrated capacitance in combination with a cable.

In other cases involving combined concentrated capacitance (Ci) and concentrated inductance (Li) in the intrinsically safe circuit, up to 50% of the value of L_0 is permitted and up to 1 μ F.

Level sensor ES4



ATEX standard	EN IEC 60079-0 (2018) EN 60079-11 (2012)
Certificate number	DNV 22 ATEX 80661X
Intrinsically safe design	II 1 G Ex ia IIA T4 Ga
Sensor type	Capacitive type ES4
Must be connected to a barrier which is galvanically isolated from earth.	
Electrical parameters	C : 500 nF, L : 10 μ H, I : 181 mA U : 25.0 V, P : 1.2 W
Enclosure class	IP 68

Damming sensor R6-S



Intrinsically safe design	II 1 G Ex ia IIA T3 Ga
Sensor type	Thermistor sensor type R6-S
Must be connected to a barrier which is galvanically isolated from earth	
Electrical parameters	C : 1 nF, L : 10 μ H, I : 200 mA U : 30.0 V, P : 1.25 W
Ambient temperature sensor	-25 - $+50^\circ$ C
Enclosure class	IP 68

Sludge sensor ES8



ATEX standard	EN IEC 60079-0:2018/AC:2020-02 EN 60079-11:2012
Certificate number	TÜV 07 ATEX 553975 X
Intrinsically safe design	II 1 G Ex ia IIA T4 Ga
Sensor type	Ultrasound type ES8
Must be connected to a barrier which is galvanically isolated from earth.	
Electrical parameters	U_i = 25,0 V, I_i = 185 mA, P_i = 1,12 W C_i = 704 nF + C_c : 338 pF/m L_i = L_c : 0,48 μ H/m (Max cable length 300m)
Ambient temperature sensor	0 - $+50^\circ$ C
Enclosure class	IP 68

EU Declaration of Conformity

This declaration certifies that the below mentioned apparatus conforms to the essential requirement of the EMC directive 2014/30/EU, Low-Voltage directive (LVD) 2014/35/EU and ATEX directive 2014/34/EU.

Description of the apparatus : OSA 3 - Separator Alarm

Manufacturer : Afriso Ema AB
Kilvågen 2
SE-232 37 Arlöv
Sweden

The construction of appliance in accordance with the following standards :

EMC:

EN 61000-6-2 (2019) Electromagnetic compatibility, Generic standards - Immunity for industrial environments.
EN 61000-6-3 (2007)/A11(2011) Electromagnetic compatibility, Generic standards - Emission standard for residential, commercial and light-industrial environments.

LVD:

EN 61010-1 (2010)/A1(2019) Safety requirements for electrical equipment for measurement, control and laboratory use. Part 1 : General requirements

ATEX:

EN IEC 60079-0 (2018) Explosive atmospheres - Part 0 : General requirements
EN 60079-11 (2012) Explosive atmospheres - Part 11 : Equipment protection by intrinsic safety 'i'

EC Type examination certificate: SP 11ATEX3644X
Ex-classification:  II (1) G [Ex ia Ga] IIA, Ta 0..+40°C

Product Quality Assurance: Presafe 18 ATEX 12341Q
Notification

Notified Body DNV; Notified body number 2460

Afriso Ema AB declares under our sole responsibility, that the equipment specified above conforms to the above mentioned Directives and Standards.

Date: 2023-01-16

Signed:



Jonas Ericson Nihlstop
CEO

Notes



Afriso Ema AB

Kilvägen 2 • 232 37 Arlöv • Sweden

Phone: +46-(0)40-92 20 50

www.afriso.se