

Uponor Flowise Alcalization tank

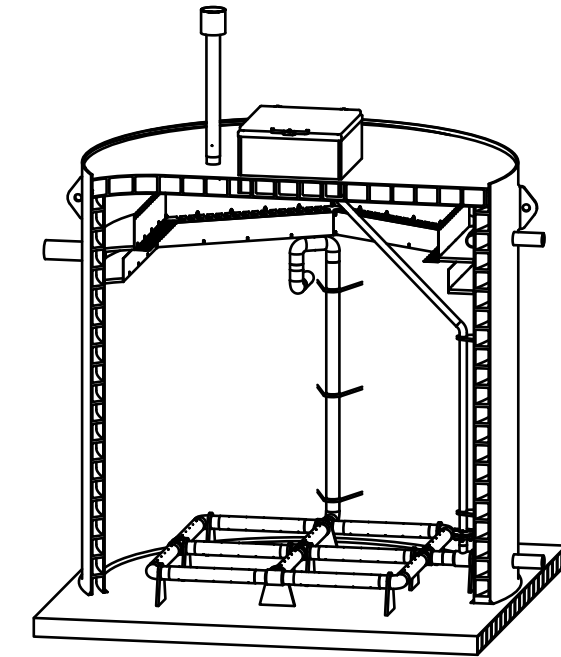

Limestone alcalization tank			
Pos.	Description	Model/Size	Qty.
1	Tank body PE100	() 2000 () 2400 () 3000 () 3400 () Other: _____	1
2	Insulate aluminium lid. Lockable	() 600x600 () 800x800	1
3	Ventilation	() DN 100 Aisi 304 () Amphyvent 125	0-1
4	Raw water Inlet pipe	DN _____	1
5	Outlet pipe	DN 100 h4: _____	1
6	Collection and spooling pipes	() DN 100 () DN 160	1
7	Spool water inlet	DN 100	1
8	Spool air connection and valve	2"	1
9	Inlet veir aerator, Adjustable		1
10	Spool water collector		1
11	Spool water outlet	DN 160	1
12	Limestone volume	_____ m ³ / h1 _____ mm	
13	Dranlage layer	Dranlage gravel,sand or fill with limestone cruch	
Attenuation time [min]			

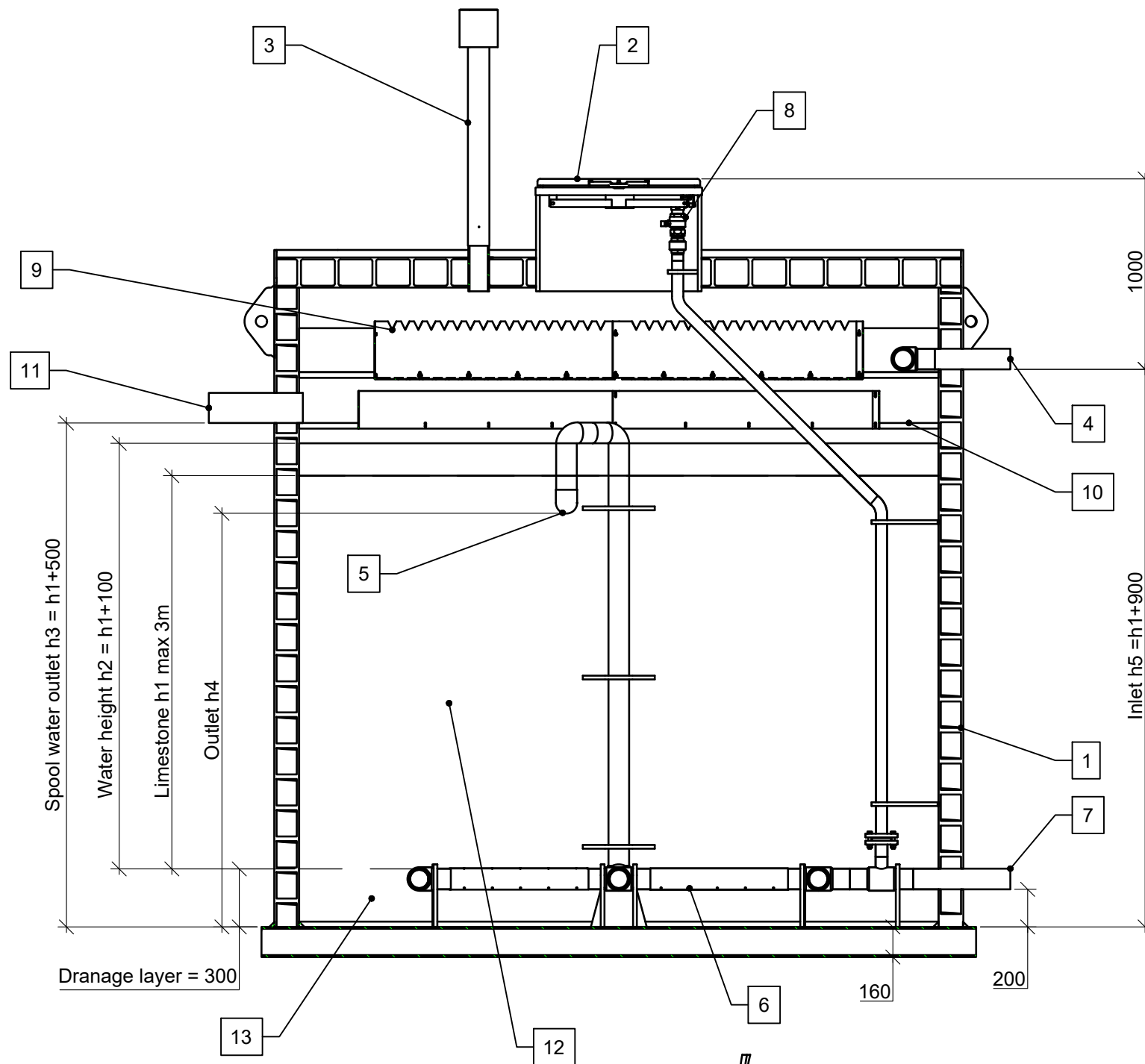
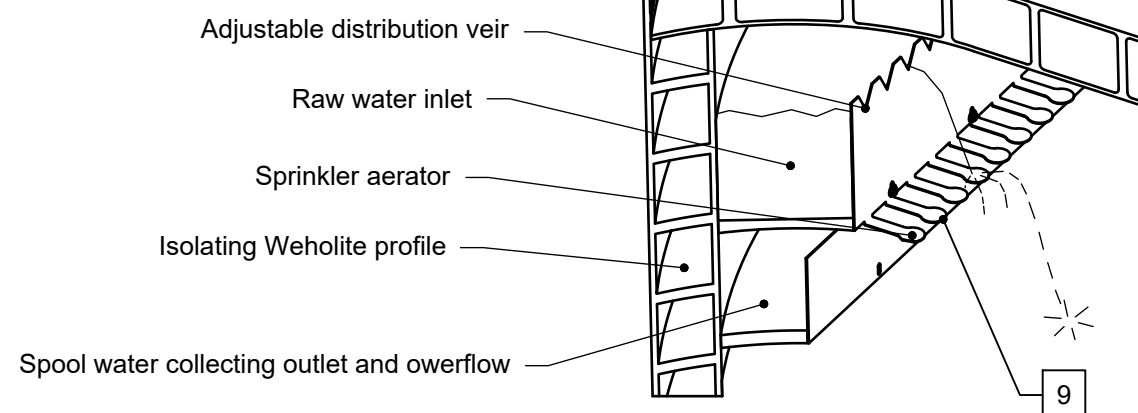

uponor

WWW.UPONOR.COM

CASE NUMBER	DRAWN BY	HANDLED BY
-	---	---
DATE	CONTACT PERSON	
09-08-2023	---	
CONTENT		
Alcalization tank		
SCALE	NUMBER	
1:30 (A3)	1140526-1	