

# Septic Tank 4,5m<sup>3</sup> (Uponor code 1136581)

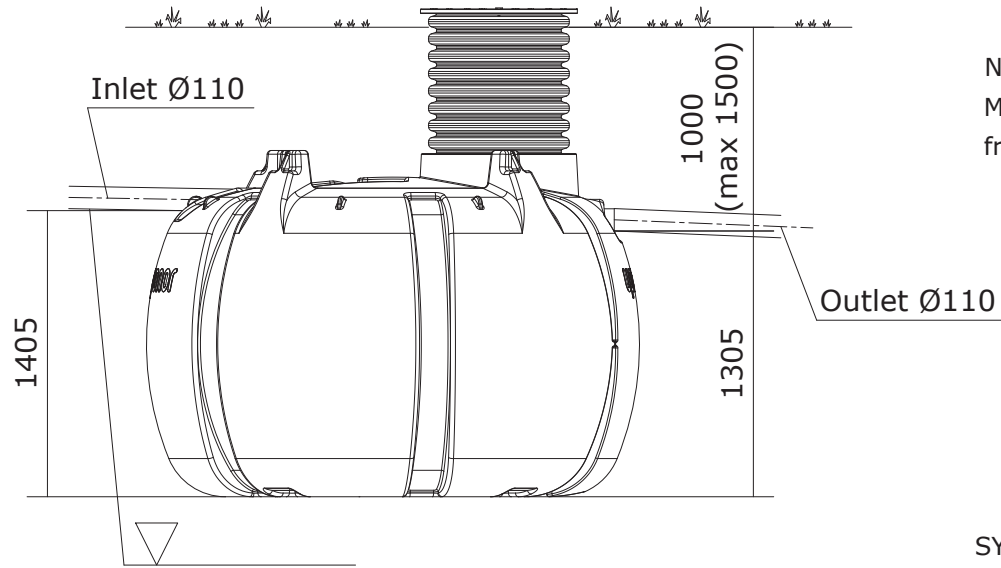

Notice  
 Max installation depth 1,5 m  
 from the outlet to the ground.

### SYSTEM DESCRIPTION:

Runtime ..... mm/y

Number of persons ..... PE

### Accessories:

- Frost insulation
- Anchoring
- Extension pipe Ø 684 with sealing ring

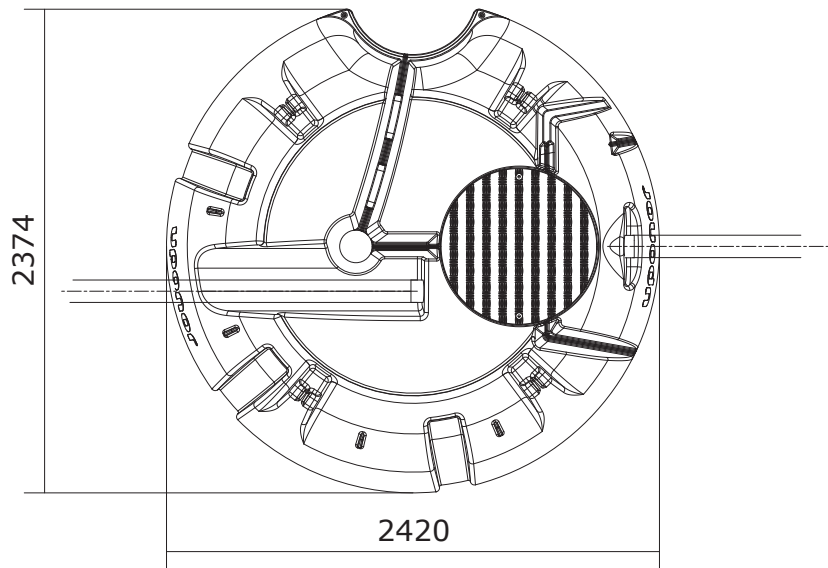

We reserve the right to changes.

**uponor**

City/Village	Block/Yard	Lot/Rno.	Notes from administrative authority	
Construction act			Drawing type	Number
Construction site: name and address			Qualifies	Scale
Designer: name, date and signature			Planning, work no. and drawing no.	Modification

# Septic Tank 4,5m<sup>3</sup> (Uponor code 1136582)

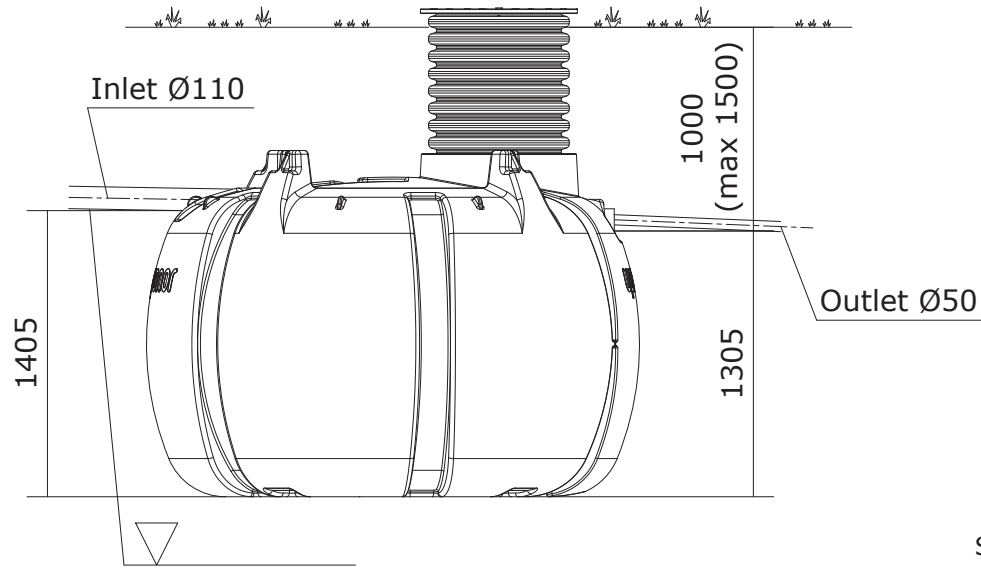

Notice  
 Max installation depth 1,5 m  
 from the outlet to the ground.

### SYSTEM DESCRIPTION:

Runtime ..... mm/y

Number of persons ..... PE

### Accessories:

- Frost insulation
- Anchoring
- Extension pipe Ø 684 with sealing ring

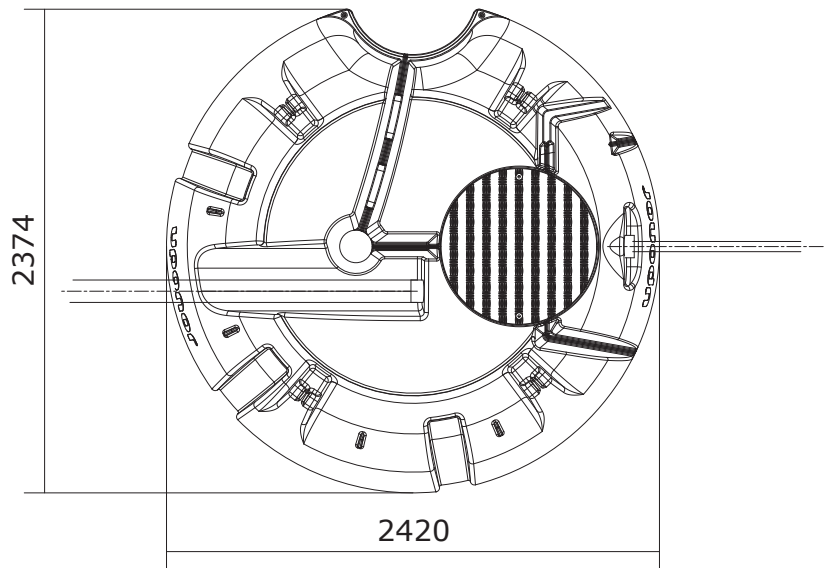

We reserve the right to changes.



City/Village	Block/Yard	Lot/Rno.	Notes from administrative authority	
Construction act			Drawing type	Number
Construction site: name and address			Qualifies	Scale
Designer: name, date and signature			Planning, work no. and drawing no.	Modification