

uponor

# Snow and ice melting system

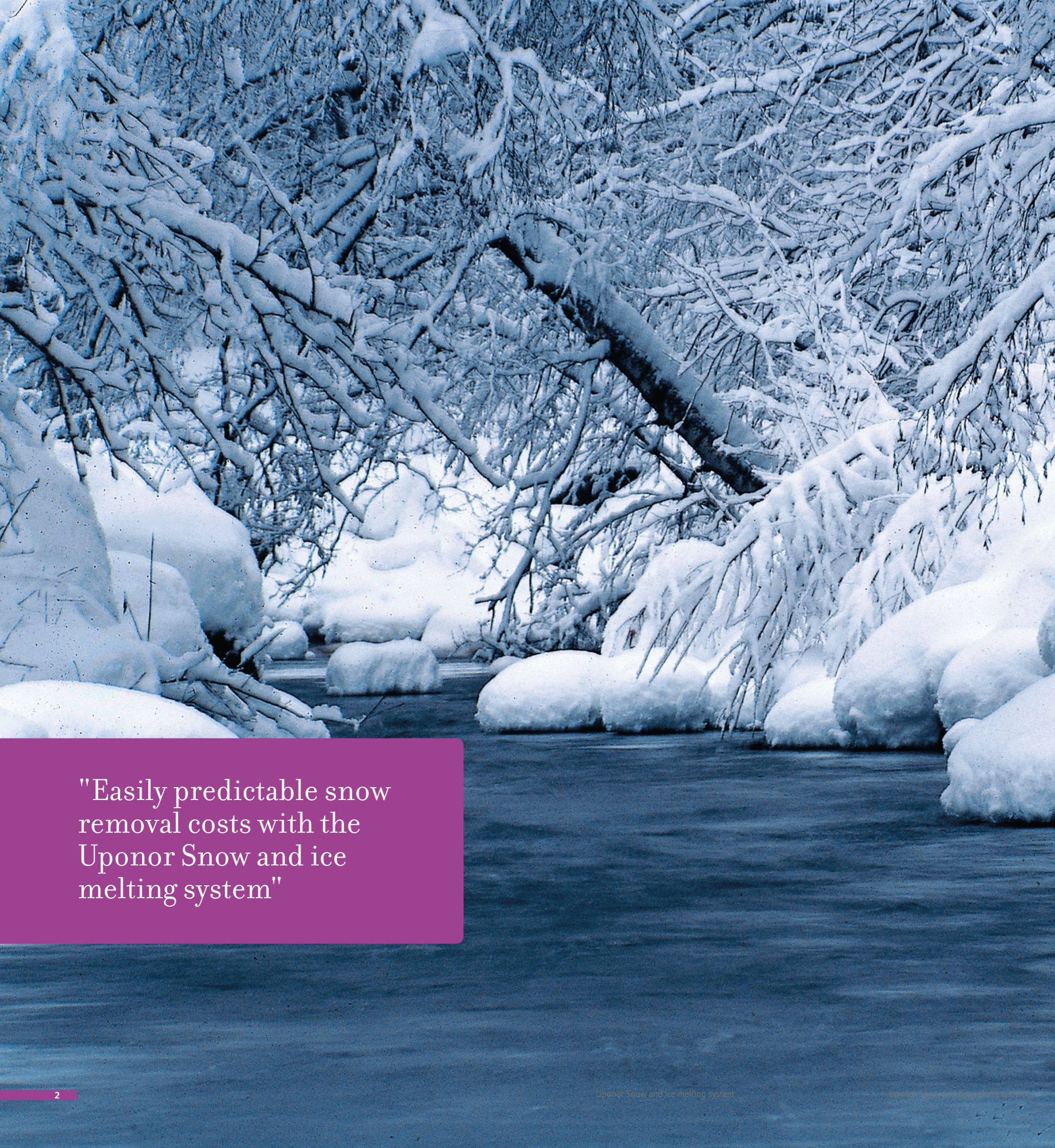



"Easily predictable snow removal costs with the Uponor Snow and ice melting system"

## Table of contents

<b>Uponor Snow and ice melting design principles</b> .....	4
<b>The design</b> .....	6
<b>Adjustable system solution for different structures</b> .....	8
<b>Installing Uponor heating pipes</b> .....	11
<b>Uponor industrial snow and ice melting system components</b> .....	12
<b>Installation of Uponor industrial manifold</b> ....	17
■ Mounting.....	17
■ Hydraulic balancing .....	18
■ Startup and testing.....	19

All technical and legal information contained in this catalogue has been carefully compiled according to the best of our knowledge. We cannot be held liable for any errors as these cannot be fully excluded. Technical guidelines, including all sections, are protected by copyright. All uses other than those permitted under the copyright law are not allowed without the approval of Uponor. This applies particularly to reproduction, re-prints, processing, storage and processing in electronic systems, translations and microfilming. The contents of the technical guidelines are subject to change without notice.

Copyright 2010 Uponor

# Uponor Snow and ice melting design principles

The Uponor Snow and ice melting system needs a minimum of +35°C water temperature to function which means that a wide variety of heat sources can be used, including district heating return water, waste heat from various processes, heat pumps, etc. The heat from any suitable source can be transferred through a heat exchanger to the Uponor Snow and ice melting system. The basic and easy design consists of Uponor PE-Xa piping with pipe c/c of 250mm and Uponor Industrial Manifold. Where the Uponor Snow and ice melting system differs from an industrial underfloor heating system is that

when it functions it is almost always at maximum operating flows and temperatures with really high capacity needs.

### Basic principle

A fundamental principle of the Uponor Snow and ice melting

system is that all loops from a given manifold should be of equal lengths. The heat will then be distributed evenly, without the use of throttling valves. Distribution pipes should be designed using Uponor's Pre-insulated pipe system for industrial buildings. The pipes have an advantage of having a

ready insulation and flexibility to install them either into the ground or to the walls. Uponor Snow and ice melting system can be rated for heat outputs ranging up to 350 W per m<sup>2</sup>. The output required is dependent on the geographical location and the requirements of the system. Thanks to our research work and long experience, we can always recommend an optimum output. The depth of installation and the loop centre-to-centre distance are also matched to the relevant system.

### Advantages

1. Very few system components with only one pipe size
2. Simple planning and installation
3. Easily predictable snow removal costs



### Simplified snow and ice melting scheme

The diagram shows a typical connection for the Snow & ice melting system. It is recommended to use a snow and ice detector to achieve better functionality and energy efficiency when using the Snow and ice melting system.

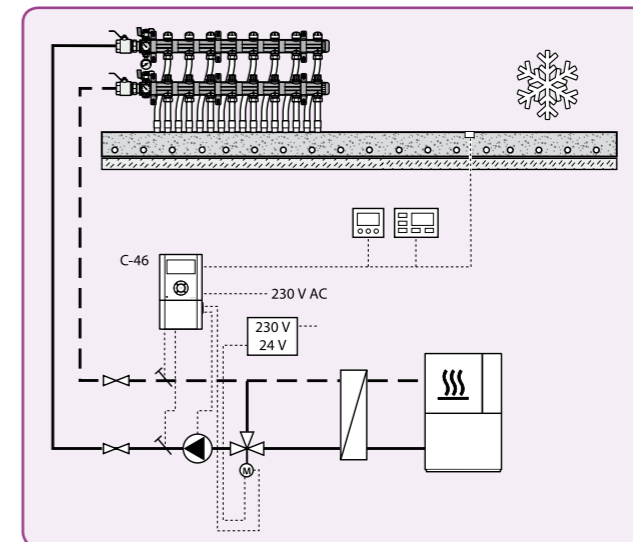

"Heat from any suitable source can be transferred through a heat exchanger to the Uponor Snow and ice melting system."

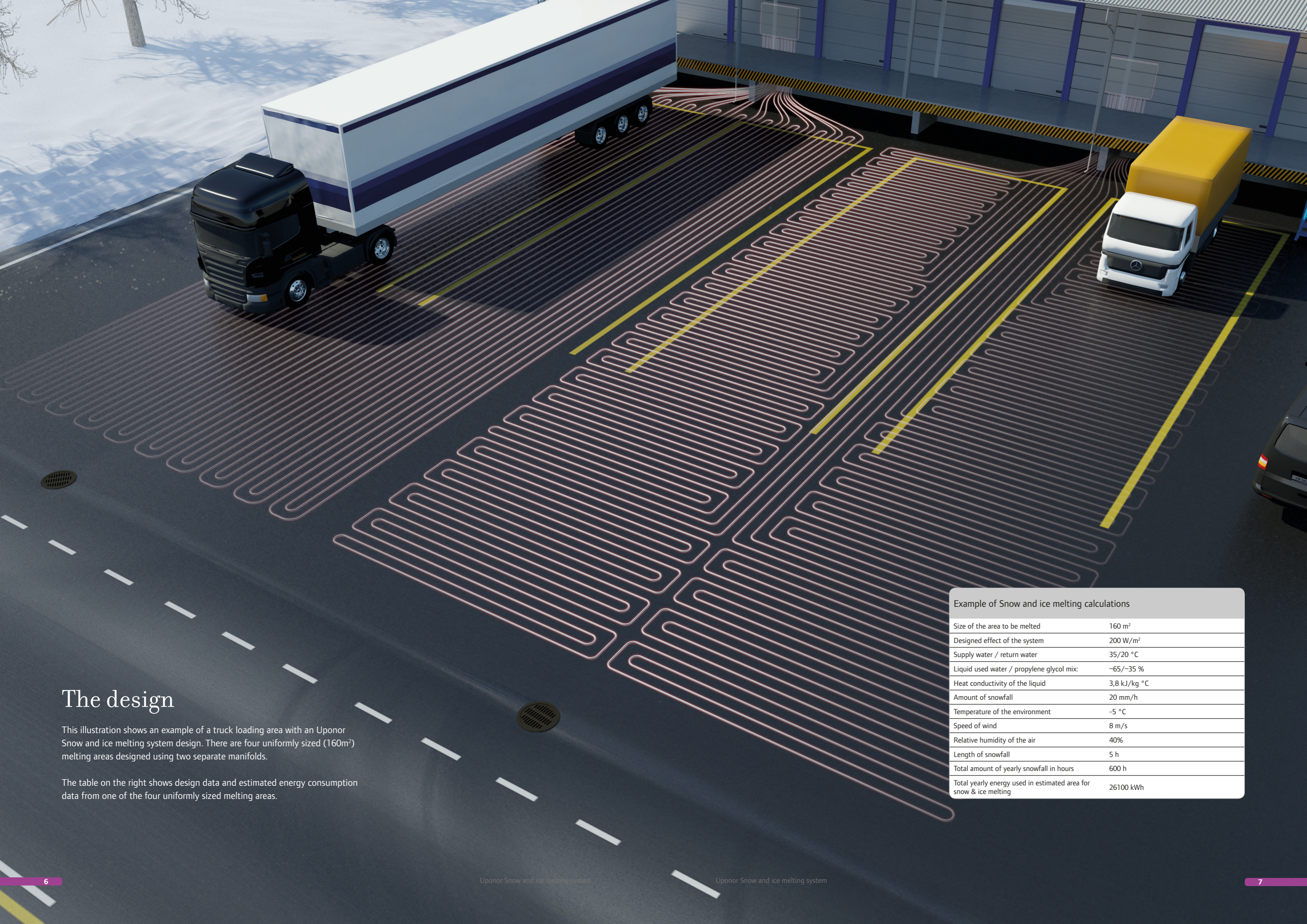

## The design

This illustration shows an example of a truck loading area with an Uponor Snow and ice melting system design. There are four uniformly sized (160m<sup>2</sup>) melting areas designed using two separate manifolds.

The table on the right shows design data and estimated energy consumption data from one of the four uniformly sized melting areas.

### Example of Snow and ice melting calculations

Size of the area to be melted	160 m <sup>2</sup>
Designed effect of the system	200 W/m <sup>2</sup>
Supply water / return water	35/20 °C
Liquid used water / propylene glycol mix:	-65/-35 %
Heat conductivity of the liquid	3,8 kJ/kg °C
Amount of snowfall	20 mm/h
Temperature of the environment	-5 °C
Speed of wind	8 m/s
Relative humidity of the air	40%
Length of snowfall	5 h
Total amount of yearly snowfall in hours	600 h
Total yearly energy used in estimated area for snow & ice melting	26100 kWh

## Adjustable system solution for different structures.

The pipe can be covered with asphalt, gravel, sand or can be cast into concrete slab. For surface heating, the pipe should be laid about 100 mm below the finished surface level and at a centre-to-centre distance of 250 mm in order to ensure a uniform temperature at the surface. Mark the U-bends on site before laying the pipes. Fill the pipes with water and pressurize them before starting surfacing work (internal pressure of 0.2 MPa).

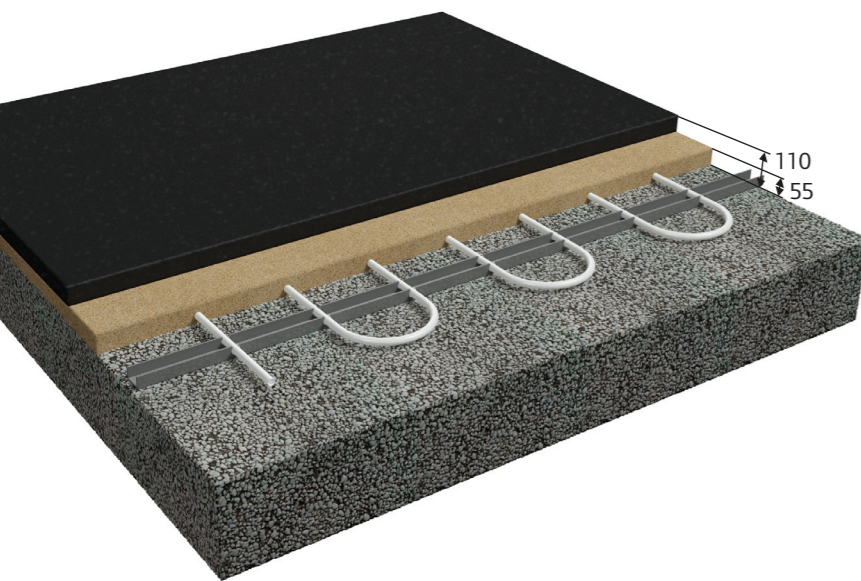

### Asphalted surfaces:

The picture on the left shows the basic installation of an asphalted structure with low wear. Mainly used for parking areas and low trafficked truck loading areas.

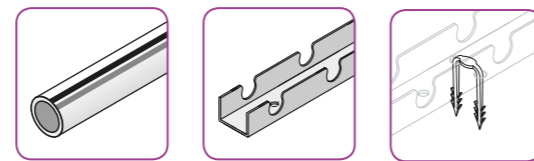

- Components:**
- Uponor PE-Xa pipe
  - Uponor PE-Xa Clamp track
  - Uponor Clamp track nail

The picture on the left shows the installation of an asphalted structure with high wear. The main usage areas are parking area ramps, high trafficked areas like roads and high truck traffic areas like the roads around logistic centers and so on.

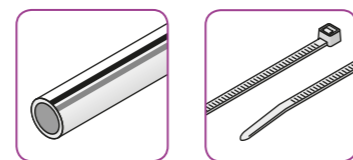
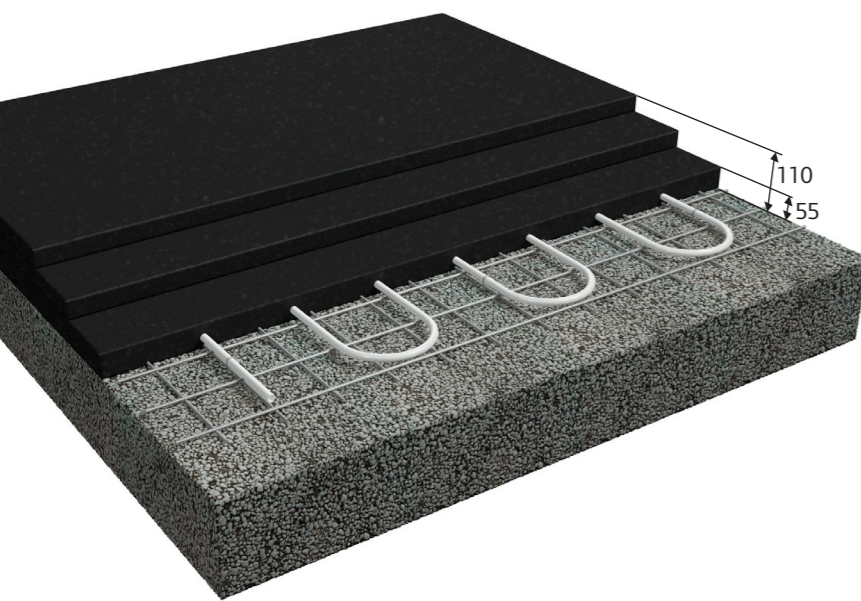

- Components:**
- Uponor PE-Xa pipe
  - Uponor Pipe tie



#### Important note for installation:

The pipe can be covered with asphalt surfacing at a maximum temperature of 120°C, provided cold water flows through the pipes while the asphalt is being laid, and that the pipe is kept under pressure of 0.2 MPa.

### Paving stones:

The picture on the right shows the installation a snow and ice melting system under paving stones. Installation is done using Uponor industrial clamp tracks. The main usage for paving stone areas include pedestrian areas and roads.

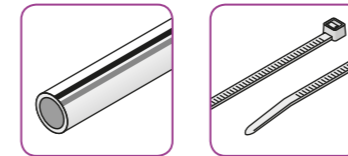

#### Components:

- Uponor PE-Xa pipe
- Uponor Pipe tie

### Slab-surfaced pavements and surfaces:

The picture on the right shows the installation of a snow and ice melting system under slab surfaced pavements and surfaces. The main usage is for pedestrian areas.

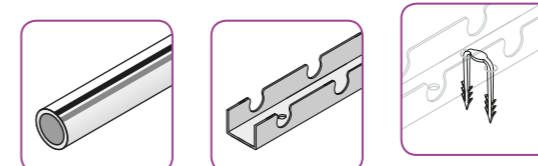

#### Components:

- Uponor PE-Xa pipe
- Uponor PE-Xa Clamp track
- Uponor Clamp track nail

### Concrete surfaces:

The picture on the right shows the installation of a snow and ice melting system into concrete cast. The actual concrete solution and its height is calculated according to structural requirements. Concrete structures might be used because of high loads - for example, aeroplane hangars. Another reason for using concrete slab can be for walking areas that are tiled instead of laid using paving stones.

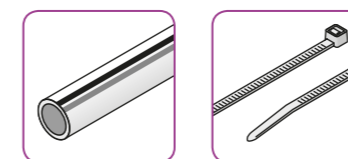

#### Components:

- Uponor PE-Xa pipe
- Uponor Pipe tie

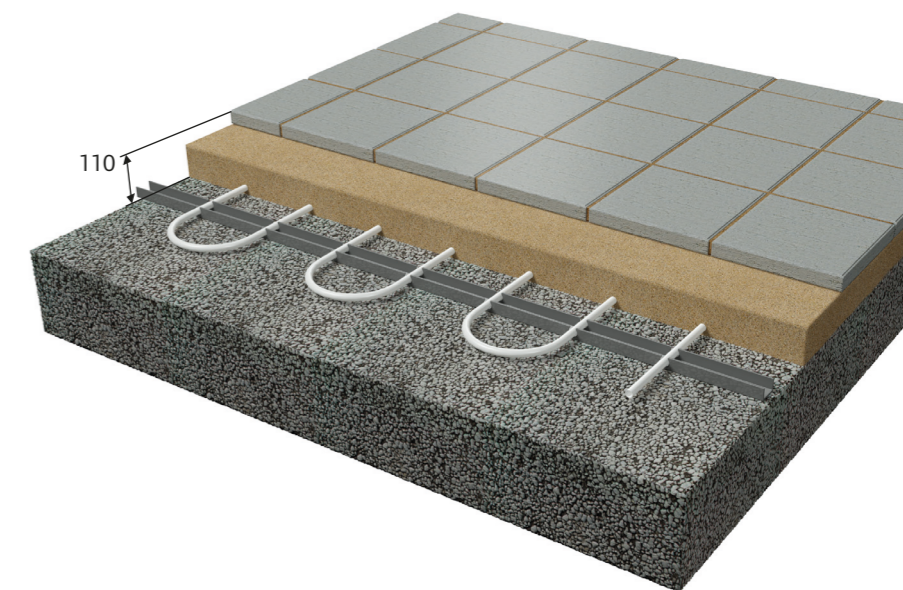
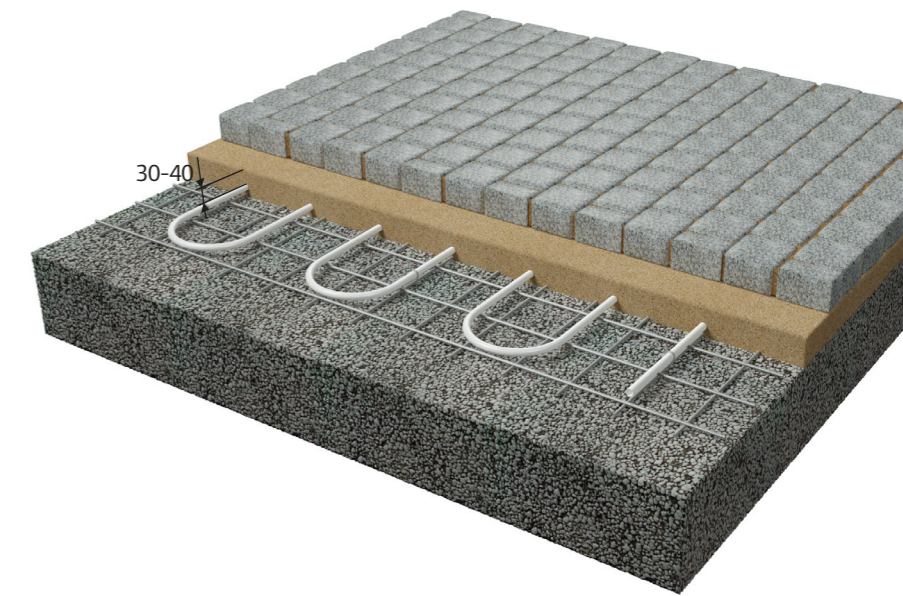

## Adjustable system solution for different structures.

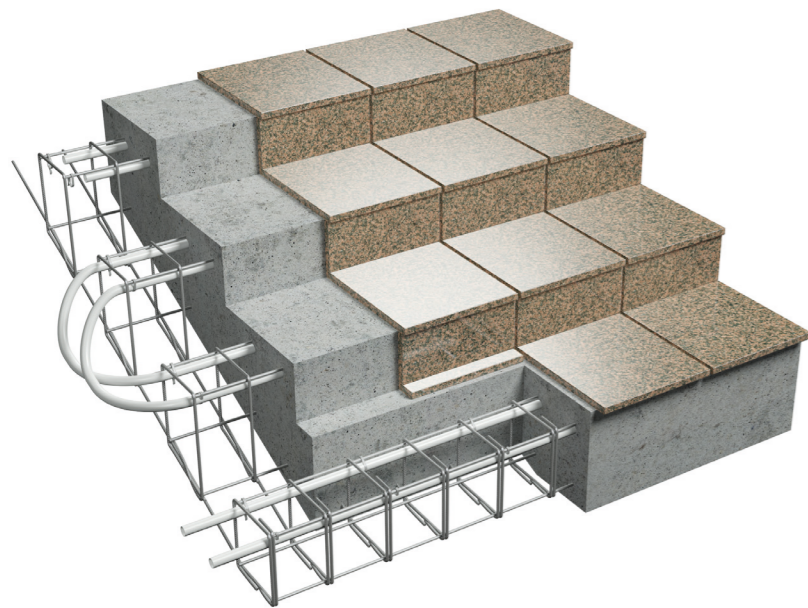

### Stairs:

The picture on the left shows an example of an Uponor Snow and ice melting system and how Uponor PE-Xa pipes can be installed to a steel reinforcement in concrete staircase.

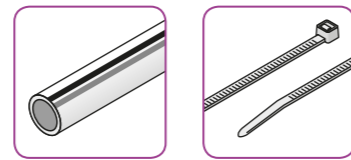

#### Components:

- Uponor PE-Xa pipe
- Uponor Pipe tie

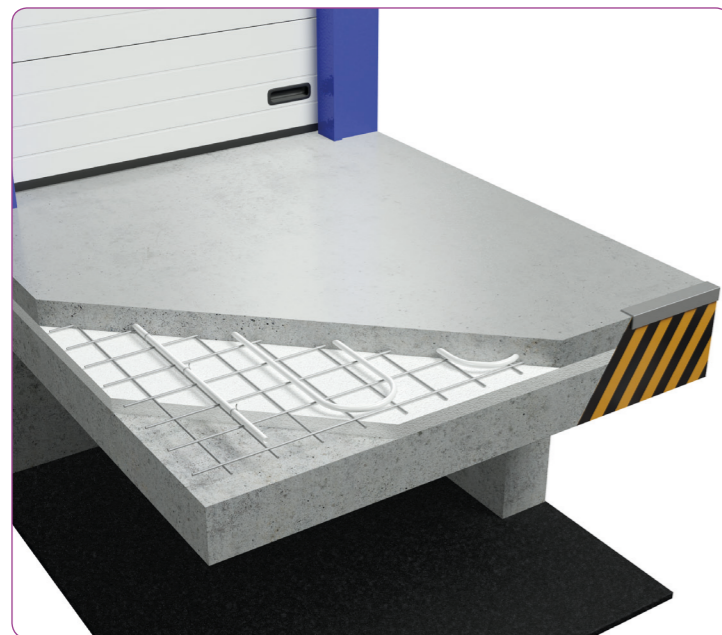

### Deck structures:

The need for insulation is normally low because of the high temperature difference between the heated surface outdoors and the ground. But when designing deck structures like loading areas or bridges the structure will also cool from underneath. In these cases it is recommended to use insulation in the structure to prevent heat loss downwards.

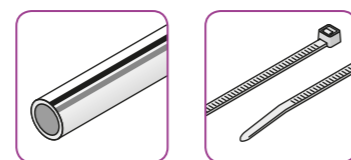

#### Components:

- Uponor PE-Xa pipe
- Uponor Pipe tie

## Installing Uponor heating pipes

The Uponor Snow and ice melting system is normally installed just underneath the surface layers of the structure. The structural requirements and load-bearing characteristics of such areas must be determined to ensure that predicted loads will not cause the piping to break. It should be noted that the installation of, and heating from, the Snow and ice melting system will not reduce structural requirements.

The brief guides describe only some aspects of the process of installing Uponor Snow and ice melting system.

### Installation with cable tie

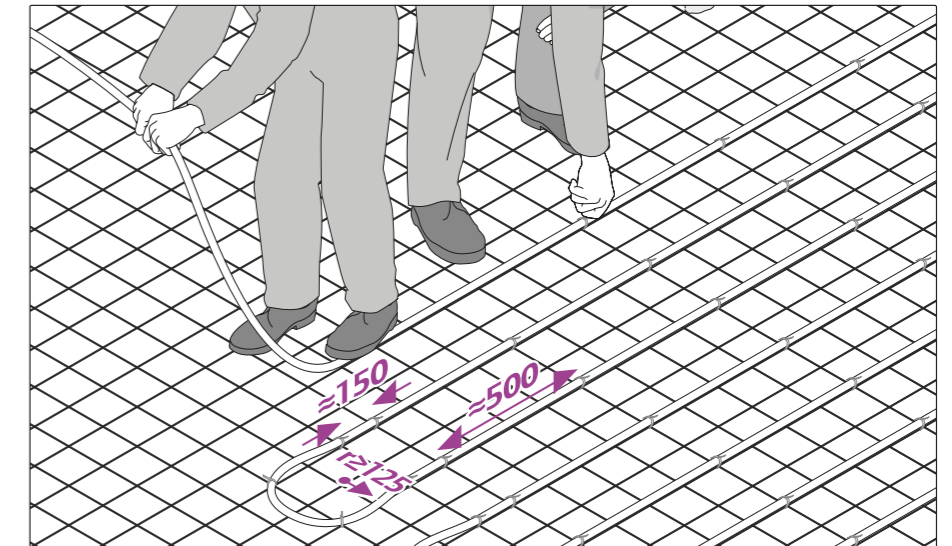

### Installation with clamp track

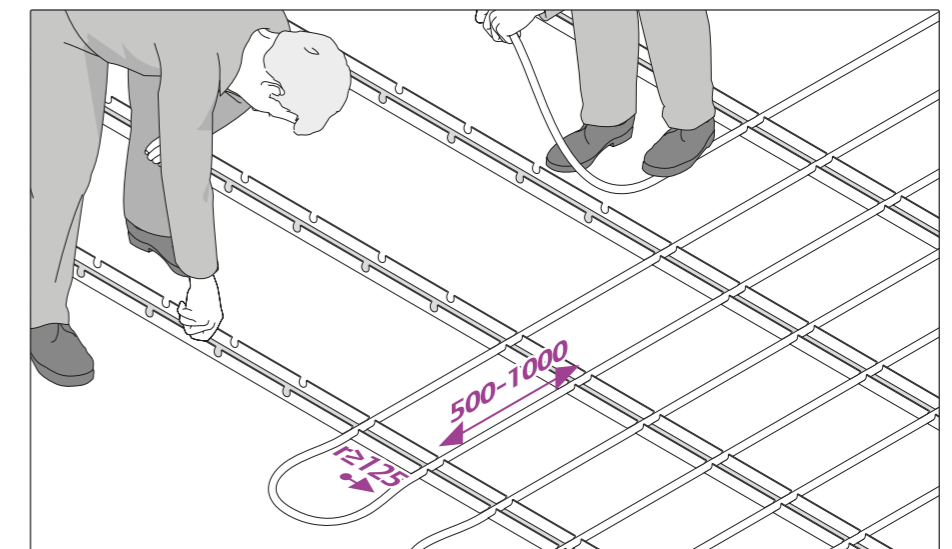

# Uponor Snow and ice melting system components

## ■ Uponor PE-Xa pipe

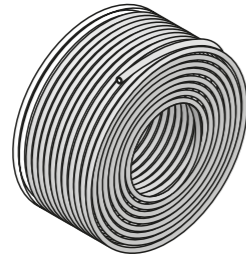

Uponor PE-Xa pipe, 25 x 2.3 mm	
Pipe dimensions	25 x 2.3 mm
Material	PE-Xa
Manufacture	As per EN ISO 15875
Oxygen impermeability	As per DIN 4726
Density	0.938 g/cm <sup>3</sup>
Thermal conductivity	0.35 W/mK
Lin. expansion coefficient	At 20 °C, 1.4 x 10 <sup>-4</sup> 1/K At 100 °C, 2.05 x 10 <sup>-4</sup> 1/K
Crystalline melting temperature	133 °C
Materials class	E
Min. bending radius	125 mm
Surface roughness of pipe	0.007 mm
Water content	0.33 l/m
Range of heating application	70 °C/7.2 bar
Max. cont. operating pressure (water at 20 °C)	15.4 bar (safety factor ≥ 1.25)
Max. cont. operating pressure (water at 70 °C)	7.2 bar (safety factor ≥ 1.5)
DIN-CERTCO registration no.	3V209 PE-X
Pipe connections	Connector couplings and clamp ring screw connections, Q&E joints, type Uponor 25 x 2.3
Preferred installation temperature	≥ 0 °C
Approved water additive	Uponor GNF antifreeze
UV protection	Optically opaque cardboard (unused portion must be stored in the box)

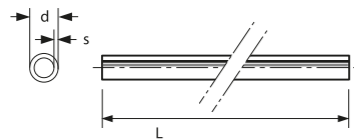

Uponor - Nr.	d [mm]	s [mm]	L [m]
1005278	25	2,3	220
1005282	25	2,3	240
1005277	25	2,3	270
1005281	25	2,3	300
1045072	25	2,3	340

## Uponor PE-Xa pipe, 25 x 2,3 mm pressure loss diagram

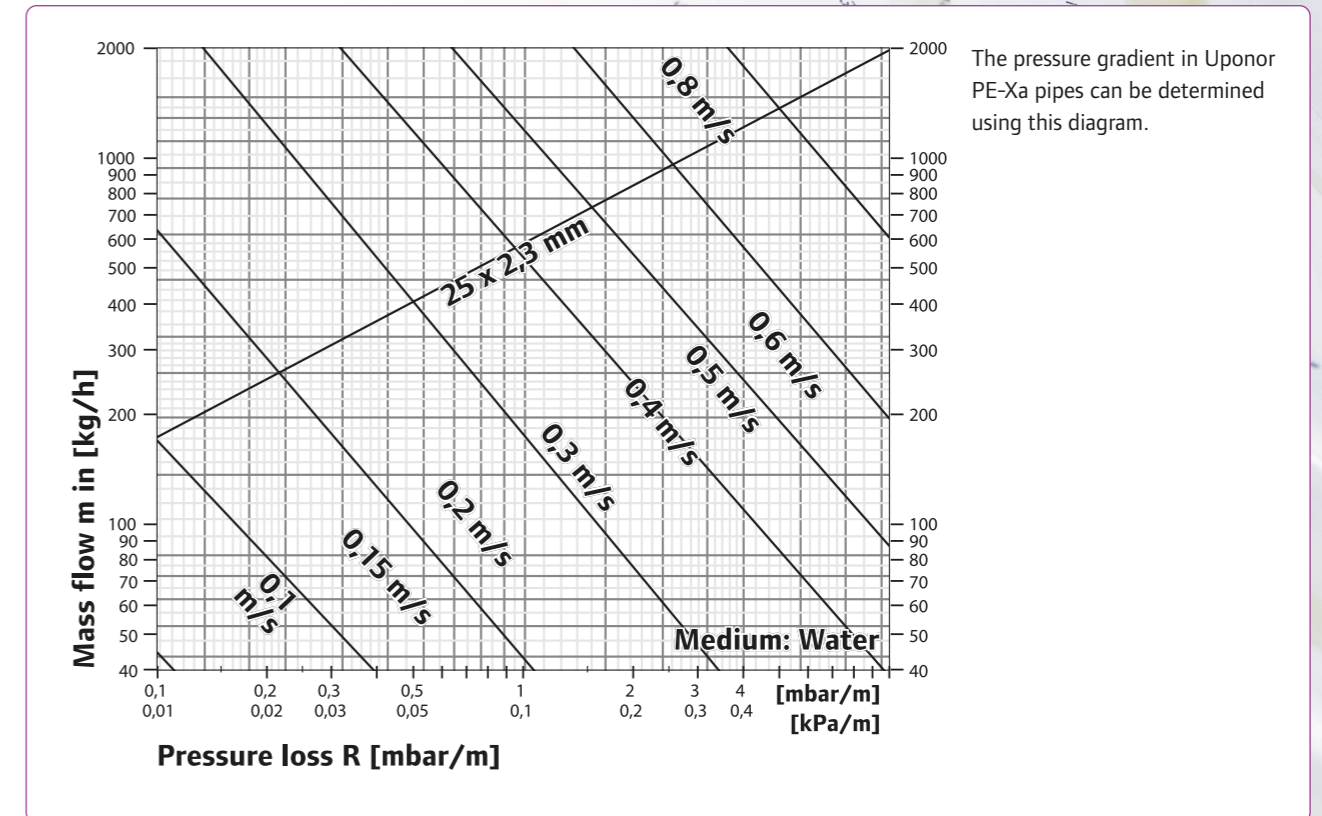

## ■ Uponor industrial manifold 25-G 11/2

Uponor Industrial Manifold 25-G 11/2 as supply and return for Industrial heating.

Consists of:

- **supply-segment with control valves for pre-adjustment, heating loop connection for PE-Xa Pipe 25x2,3 with compression adapter.**
- **return-segment with thermostat upper section incl. cap for locking. Uponor actuator can be mounted directly on the return manifold, heating loop connection for PE-Xa Pipe 25x2,3 with compression adapter.**

**Spacing of outlet:** 100 mm

Uponor - Nr.  
1045813

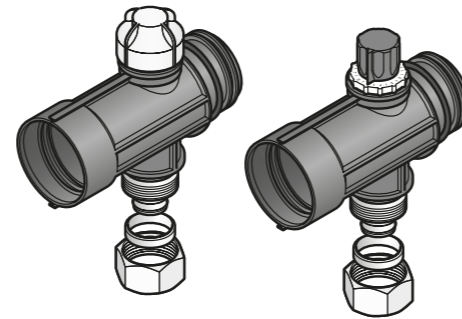

## ■ Uponor industrial manifold basic kit

Uponor Industrial Manifold Basic Kit for assembly and mounting the industrial manifold, consists of:

- 2 brackets short
- 2 brackets long
- 2 filling valves brass
- 2 thermometers 0 - 60°C
- 1 manometer
- 2 endcaps
- 2 flat sealing screw connection pieces with swivel nut
- 1 mounting material:
  - 8x screws 6x60mm
  - 8x plastic anchors 8x40mm
  - 2x flat sealings 44x32x2

Uponor - Nr.  
1045815

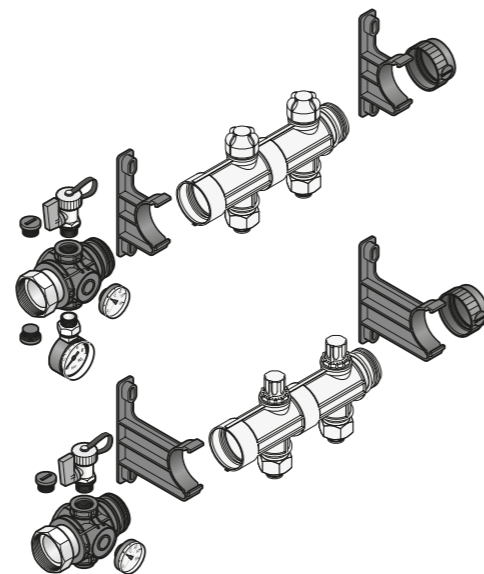

## ■ Uponor industrial manifold bracket kit

Uponor Industrial Manifold Bracket Kit for mounting the Industrial manifold. Includes mounting materials.

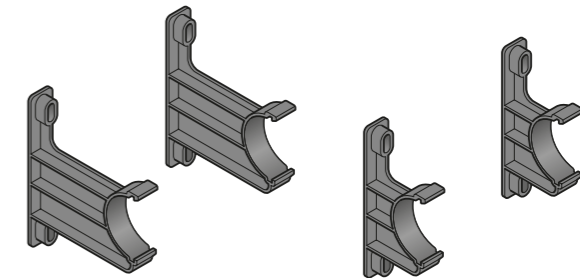

Uponor - Nr.  
1045816

## ■ Uponor industrial ball valve G11/2

Uponor Industrial Ball Valve G 11/2 for use with the Uponor Industrial manifold G 11/2 connection:

- G 11/2 FT
- G 11/2 MT

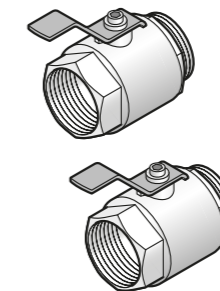

Uponor - Nr.  
1030135

## ■ Uponor Cable Tie

For fastening Uponor pipes on reinforcement steel mesh. Made of polyamide.

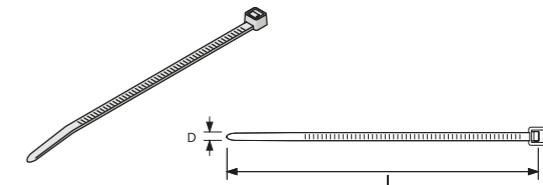

Uponor - Nr.	b [mm]	h [mm]
1005287	5	200
1005372	7	300

## ■ Uponor Pipe Bend Support

Made of impact resistant plastic to provide 90° bend.

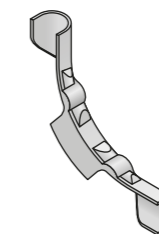

Uponor - Nr.  
1001230



## ■ Uponor Industrial Clamp track for 25mm pipe

Uponor clamp track for 25 mm pipes.

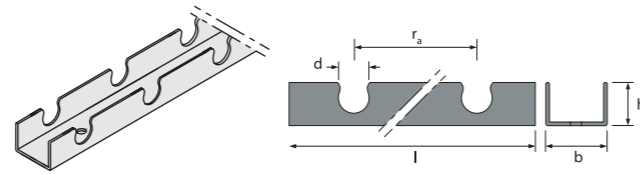

Uponor - Nr.	b [mm]	h [mm]	d [mm]	r <sub>a</sub> [mm]	l [mm]
1005290	50	34	25	50	3000

## ■ Uponor Fastening Nails for Clamp Track

For fastening the Uponor clamp track 25.

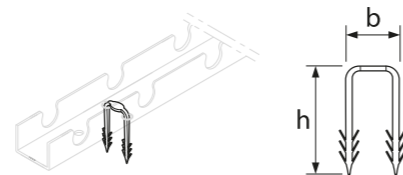

Uponor - Nr.	b [mm]	h [mm]
1005291	36	50

## ■ Uponor Pipe Clip

For fastening Uponor pipes on reinforcement steel mesh.

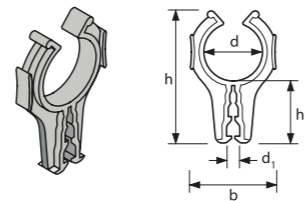

Uponor - Nr.	h [mm]	h <sub>1</sub> [mm]	b [mm]	d [mm]	d <sub>1</sub> [mm]
1005289	57	27	38	25	3-8

## ■ Uponor Industrial Pipe Uncoiler

For pipe dimension of 25 and coil length of 300 m.

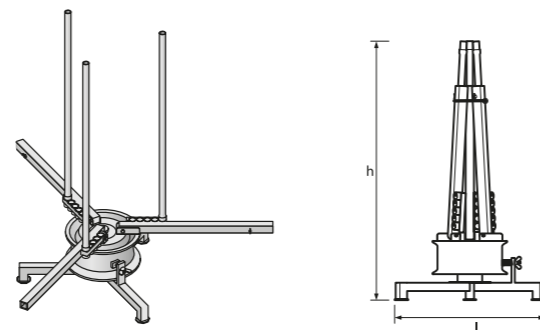

Uponor - Nr.	l [mm]	h [mm]
1006256	740	1300

## Installation of Uponor industrial manifold

### ■ Mounting

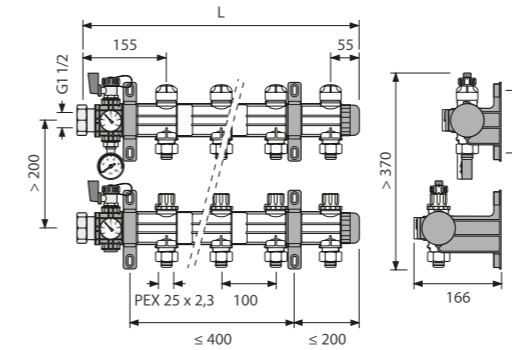

#### Technical data:

Connection dimensions	G 1½
Max. operating temperature	70°C
Max. operating pressure	6 bar
Max. test pressure (24 h, ≤ 30°C)	10 bar
kvs value inlet/outlet valves	2,35 m³/h
Max. flow rate per manifold	10 m³/h
Maximum number of loops	20

Circuits	2	3	4	5	6	7	8	9	10	11	12	13	14	15	16	17	18	19	20
L [mm]	310	410	510	610	710	810	910	1010	1110	1210	1310	1410	1510	1610	1710	1810	1910	2010	2110
Required clamps	2	2	2	2	3	3	3	3	4	4	4	4	4	5	5	5	5	5	6

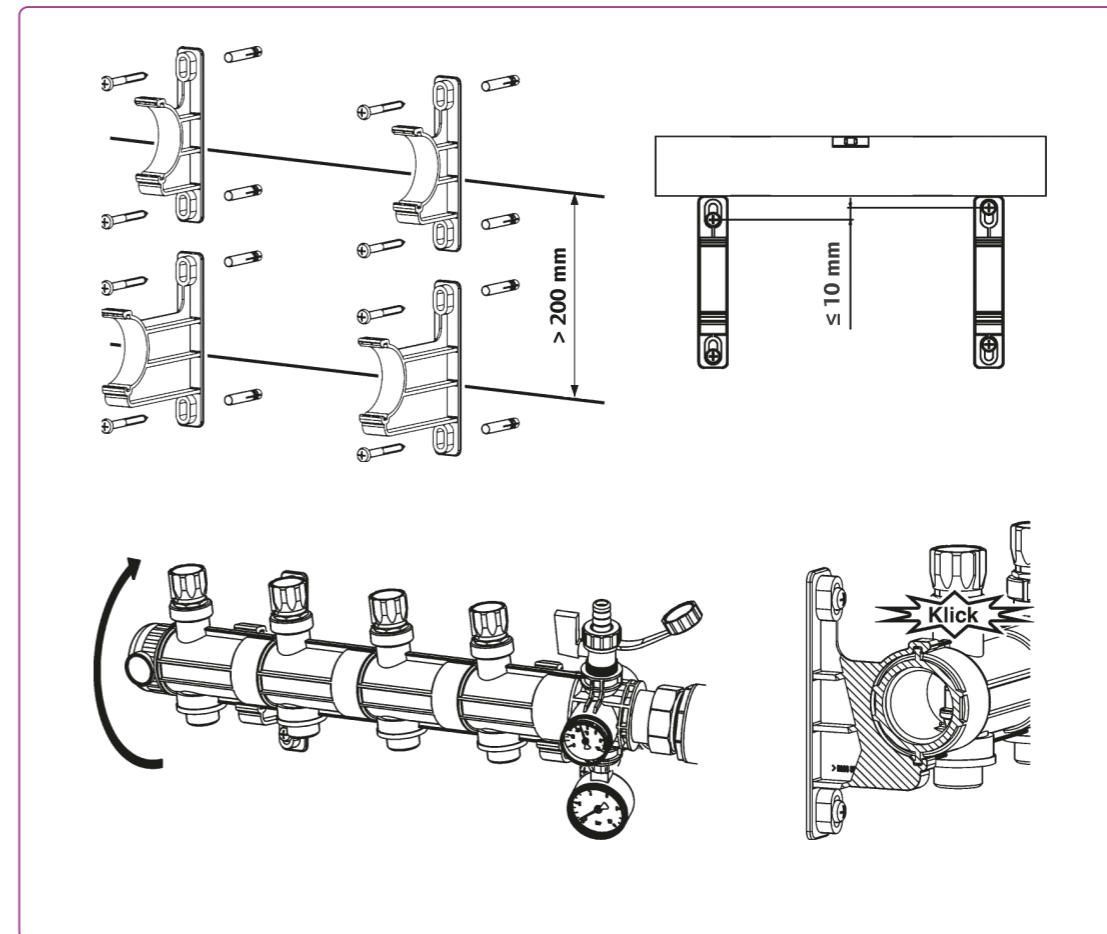

## Hydraulic balancing

A

B

1. Determine the setting valve.
2. Close the supply valves.
3. Set the setting value (1) on the ring.
4. Open the supply valves.

A

1. Open the supply valve until the calculated water quantity (1) is displayed on the flow meter
2. Turn the ring to the stop of the supply valve

B

## Startup and testing

### Fill pipes

1. Connect the hose to the boiler fill and drain valve and open the boiler fill and drain valve.
2. Open the return valve of the first heating circuit **a**. Open the supply valve of the first heating circuit **b**. Close all other valves **c**.
3. Fill the system to max. 5 bar and rinse it.
4. Close the supply and return valves of the filled heating circuit
5. Repeat the filling and rinsing procedure (steps 1 and 2) for all further heating circuits
6. Bleed the system at the boiler fill and drain valve.

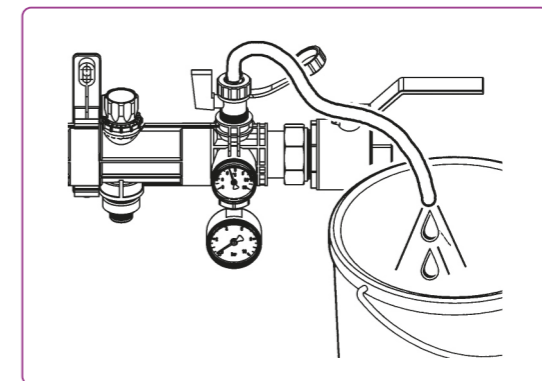
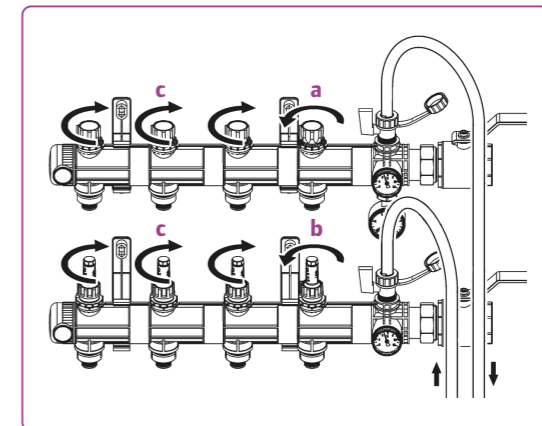

### Pressure test

1. Pressurise the system to 6 bar for 2 hours.
2. After 2 hours perform a leak test (the decrease in pressure may not exceed 0.2 bar)

Fill the system with water until the operating pressure is reached

Uponor offers construction professionals uncompromising quality, industry-leading expertise and long-lasting partnerships. As a leading international company, we are known for our solutions that help create better human environments.

Uponor's Simply More philosophy includes services for all stages of the construction process – from the first concept of a project to a building in use.

**Uponor Corporation**  
**Robert Huberin tie 3 B**  
**FIN-01511 VANTAA**  
**Finland**  
**+358 20 129 211**  
**[www.uponor.com](http://www.uponor.com)**

**uponor**  
simply more