

UPONOR STORMWISE
Vortex Chamber
 Traffic area

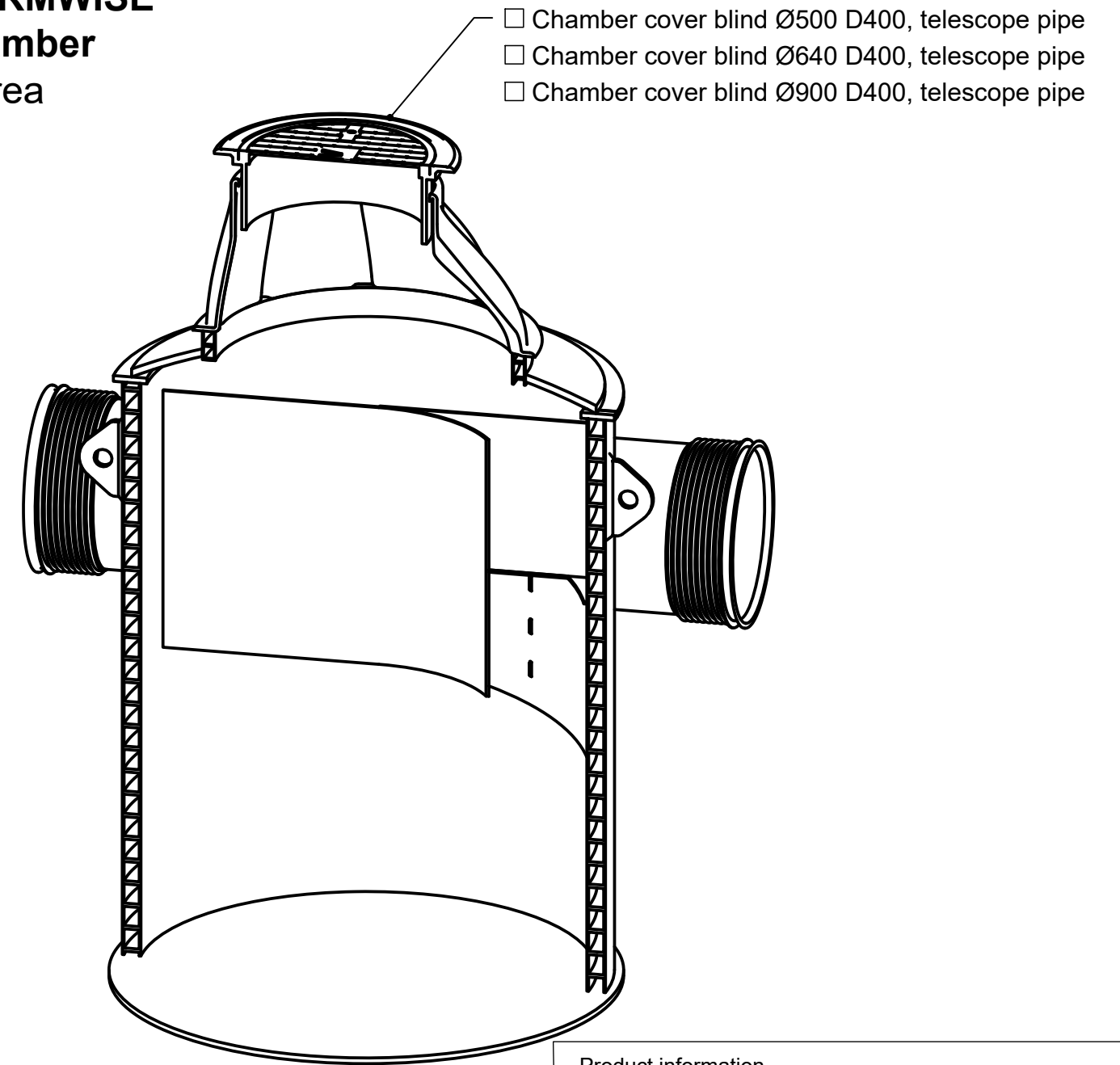
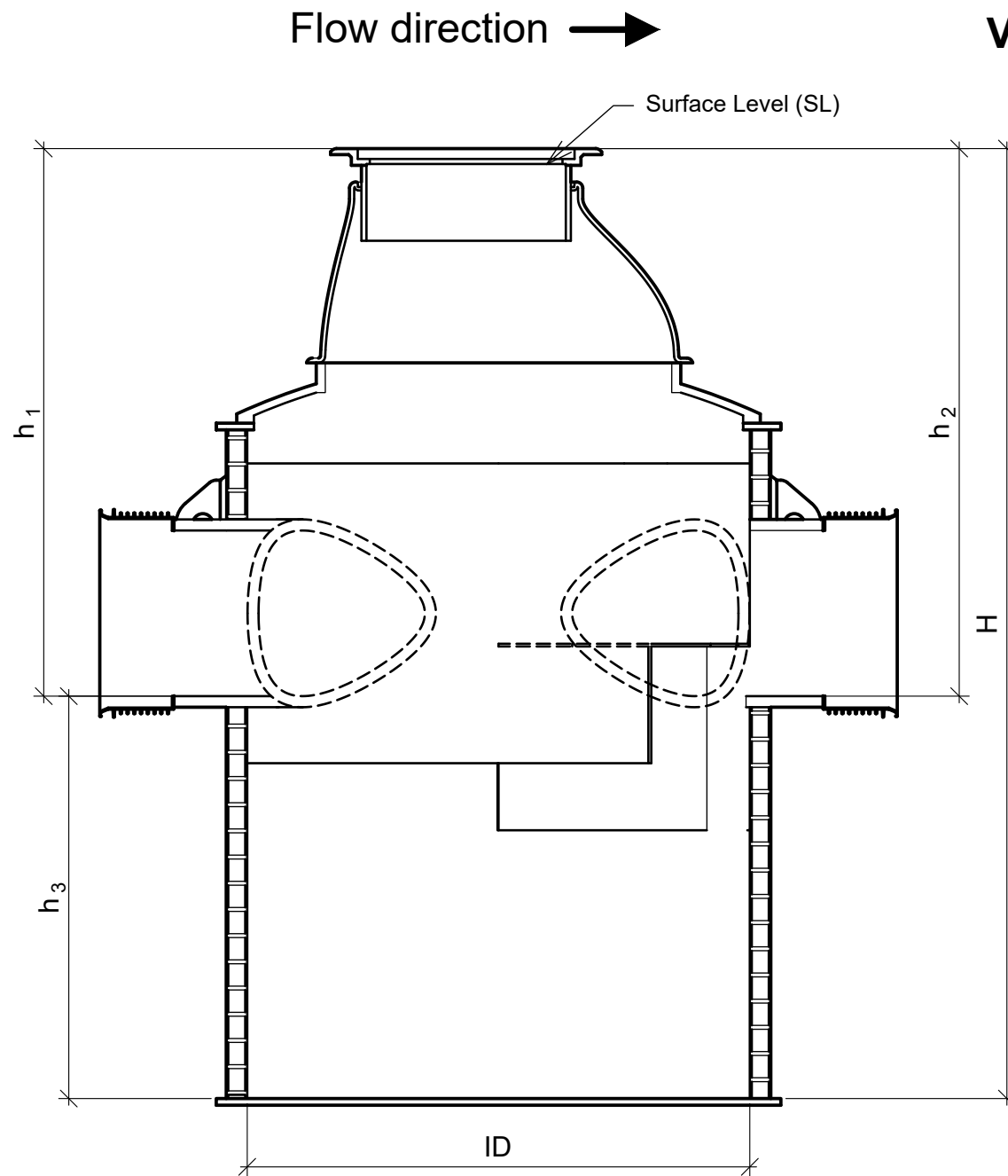

Vortex						
	V1200	V1500	V1800	V2400	V3000	V3500
ID	1200	1500	1800	2400	3000	3500
DN	400	500	600	800	1000	1200
Sedimentvolume (L)	352	550	792	1407	2199	3167
Oilvolume (L)	133	432	631	1106	1825	2846
h_1	≥1632	≥1633	≥1800	≥1900	≥2100	≥2300
h_2	≥1632	≥1633	≥1800	≥1900	≥2100	≥2300
h_3	1200	1200	1200	1200	1200	1200
H	2850	2580	3030	3160	3460	3660
Max flow (l/s)	160	300	500	1000	1800	3000
Functional flow (l/s)	30	60	100	200	360	600

Product information

Connection pipe type and DN: _____

h_1 (mm): _____ h_2 (mm): _____

Groundwater: Yes No If Yes, SL-GW: _____

Comments: _____



CASE NUMBER	DRAWN BY	HANDLED BY
	---	---
DATE	CONTACT PERSON	
09.02.2023	---	
CONTENT		
Uponor Stormwise Vortex		
SCALE	NUMBER	
1:20 (A3)	1139922-T	