

Flow direction →

Uponor Stormwise Filter Chamber

Traffic area

- Chamber cover blind Ø500 D400, telescope pipe
- Chamber cover blind Ø640 D400, telescope pipe
- Chamber cover blind Ø900 D400, telescope pipe

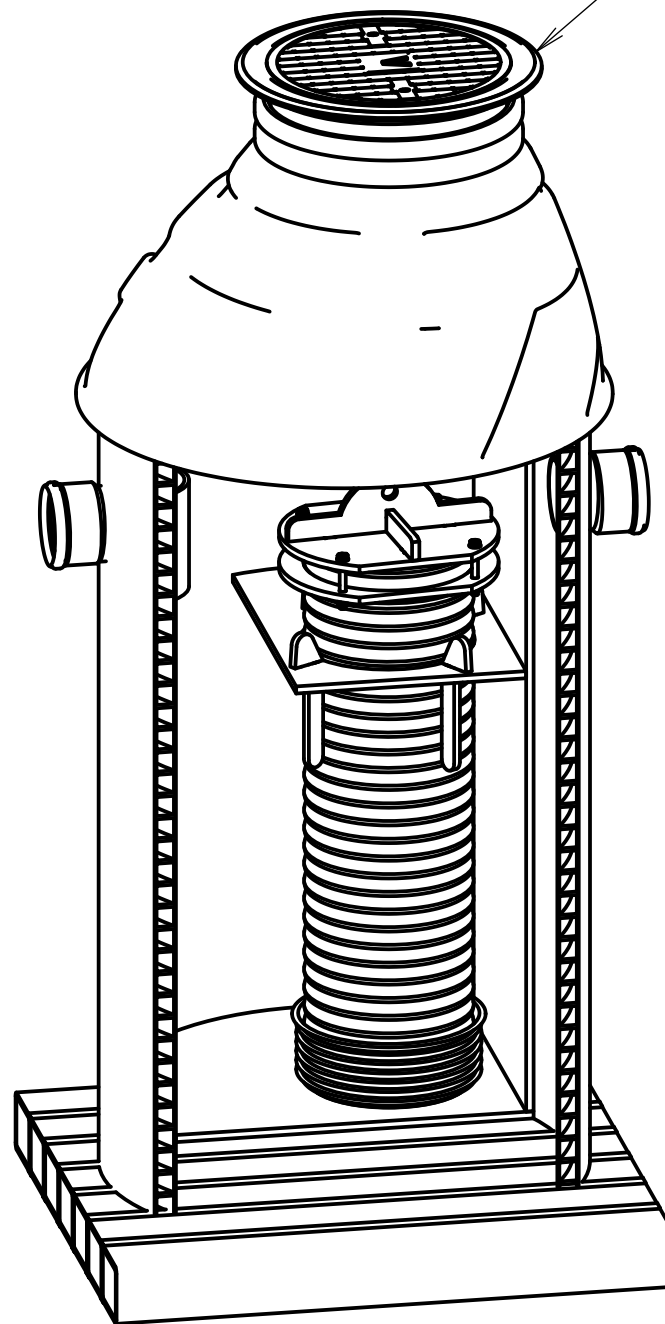
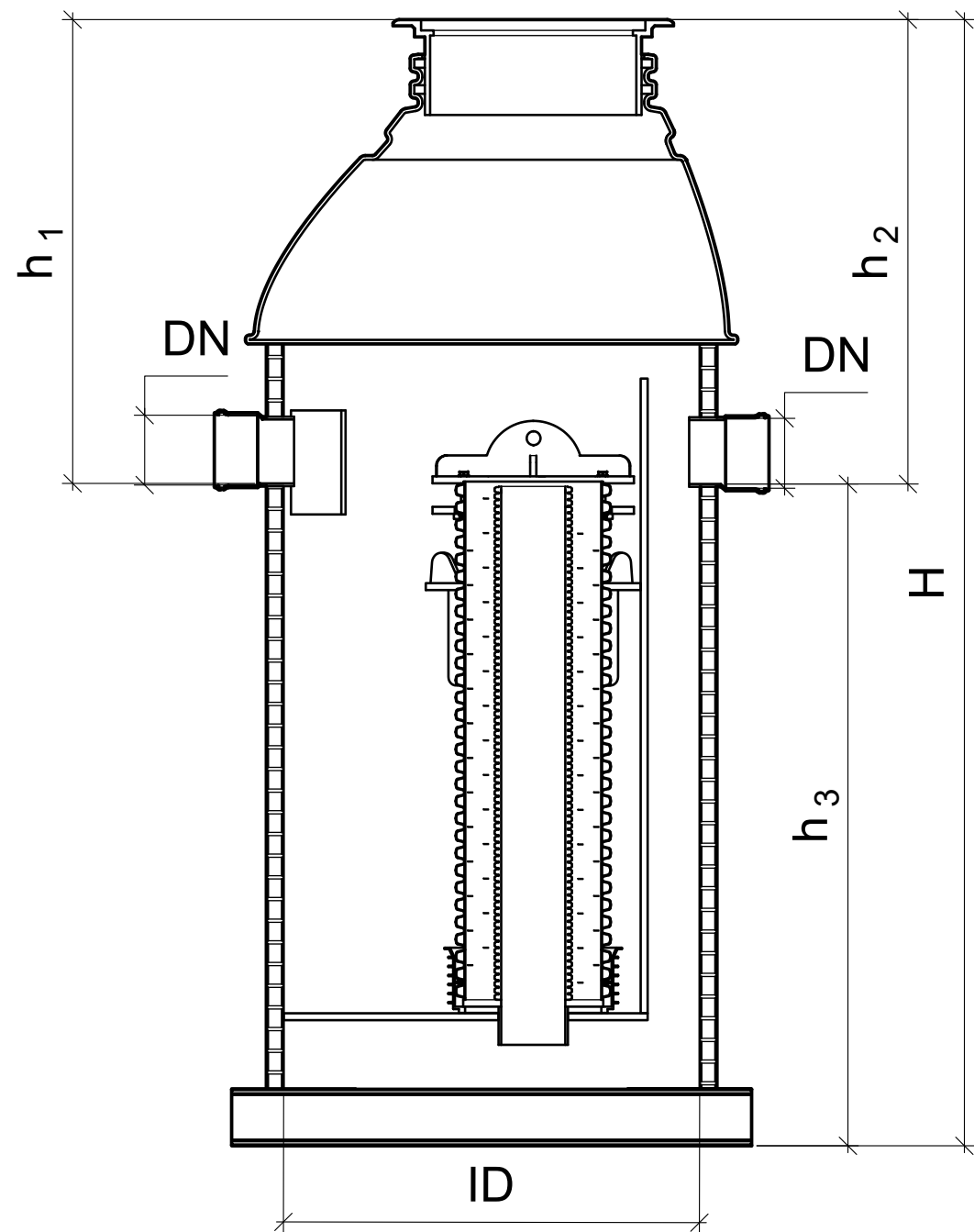

Product information

Connection pipe type and DN: _____

h_1 (mm): _____ h_2 (mm): _____

Groundwater: Yes No If Yes, SL-GW: _____

Comments:

Spareparts

Filters:

- Filter 1,5m: Article number 1135105
- Liters per filter: 130L
- Filter 2,0m: Article number 1135106
- Liters per filter: 180L

Filter chamber

DN	DN160	DN200	DN250	DN315	DN400	DN400	DN500
ID	1000	1200	1400	1600	1600	2400	2400
Max Flow (l/s)	25	50	75	100	150	200	300
Functional Flow (l/s)	5,0	10	15	20	30	40	60
Filter	1,5mx1pcs	1,5mx1pcs	2,0mx1pcs	1,5mx2pcs	2,0mx2pcs	1,5mx4pcs	2,0mx4pcs
H	≥2865	≥3245	≥3665	≥3155	≥3815	≥3510	≥4030
h_1	≥1040	≥1335	≥1230	≥1245	≥1380	≥1600	≥1600
h_2	≥1040	≥1335	≥1230	≥1245	≥1380	≥1600	≥1600
h_3	≥1825	≥1910	≥2435	≥1910	≥2435	≥1910	≥2430



CASE NUMBER	DRAWN BY	HANDLED BY
	---	---
DATE	CONTACT PERSON	
30.09.2022	---	
CONTENT		
Uponor Stormwise Filter Chamber		
SCALE	NUMBER	
1:20 (A3)	1138347-T	