

Uponor Smatrix Base/Base PRO

EN Installation report

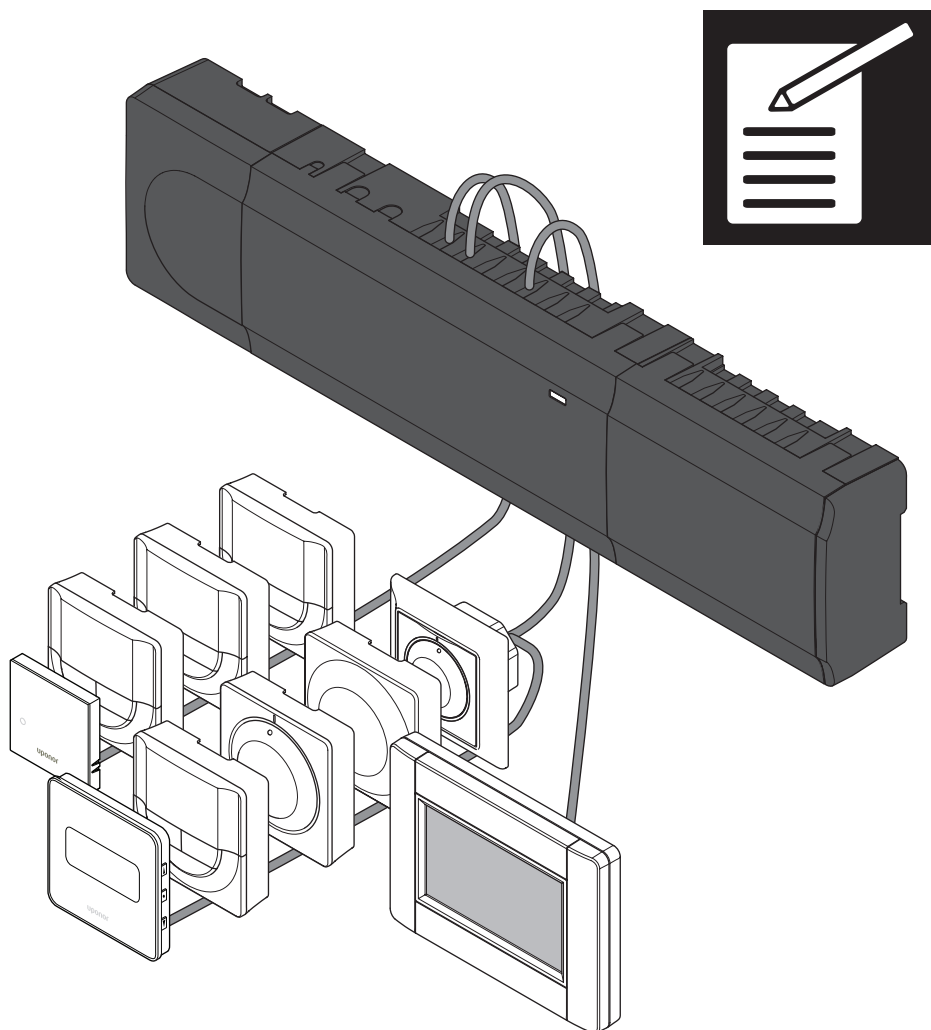

System overview



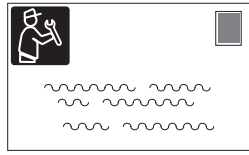
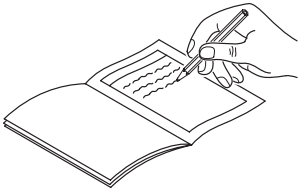

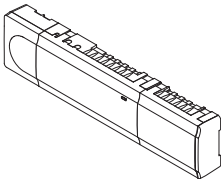
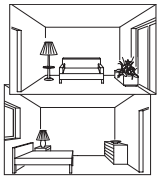

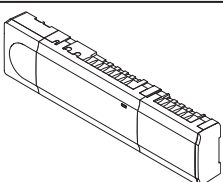
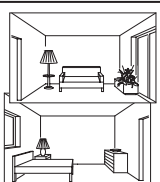

EN



	Controller								
	# 1	# 2	# 3	# 4	# 5	# 6	# 7	# 8	
Registered system device									Room name
Interface									
Timer									
Outdoor sensor									
Heating/cooling switch sensor									
ECO/Comfort switch									
Pump	Yes <input type="checkbox"/>	Yes <input type="checkbox"/>	Yes <input type="checkbox"/>	Yes <input type="checkbox"/>	Yes <input type="checkbox"/>	Yes <input type="checkbox"/>	Yes <input type="checkbox"/>	Yes <input type="checkbox"/>	
	No <input type="checkbox"/>	No <input type="checkbox"/>	No <input type="checkbox"/>	No <input type="checkbox"/>	No <input type="checkbox"/>	No <input type="checkbox"/>	No <input type="checkbox"/>	No <input type="checkbox"/>	
Star module	Yes <input type="checkbox"/>	Yes <input type="checkbox"/>	Yes <input type="checkbox"/>	Yes <input type="checkbox"/>	Yes <input type="checkbox"/>	Yes <input type="checkbox"/>	Yes <input type="checkbox"/>	Yes <input type="checkbox"/>	
	No <input type="checkbox"/>	No <input type="checkbox"/>	No <input type="checkbox"/>	No <input type="checkbox"/>	No <input type="checkbox"/>	No <input type="checkbox"/>	No <input type="checkbox"/>	No <input type="checkbox"/>	

	Controller								
	# 9	# 10	# 11	# 12	# 13	# 14	# 15	# 16	
Registered system device									Room name
Interface									
Pump	Yes <input type="checkbox"/>	Yes <input type="checkbox"/>	Yes <input type="checkbox"/>	Yes <input type="checkbox"/>	Yes <input type="checkbox"/>	Yes <input type="checkbox"/>	Yes <input type="checkbox"/>	Yes <input type="checkbox"/>	
	No <input type="checkbox"/>	No <input type="checkbox"/>	No <input type="checkbox"/>	No <input type="checkbox"/>	No <input type="checkbox"/>	No <input type="checkbox"/>	No <input type="checkbox"/>	No <input type="checkbox"/>	
Star module	Yes <input type="checkbox"/>	Yes <input type="checkbox"/>	Yes <input type="checkbox"/>	Yes <input type="checkbox"/>	Yes <input type="checkbox"/>	Yes <input type="checkbox"/>	Yes <input type="checkbox"/>	Yes <input type="checkbox"/>	
	No <input type="checkbox"/>	No <input type="checkbox"/>	No <input type="checkbox"/>	No <input type="checkbox"/>	No <input type="checkbox"/>	No <input type="checkbox"/>	No <input type="checkbox"/>	No <input type="checkbox"/>	

Controller 1

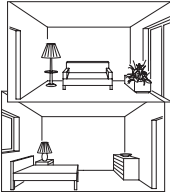
Thermostat	Controller channel						Extension module channel					
	1	2	3	4	5	6	7	8	9	10	11	12
 T-149												
 T-148												
 T-146												
 T-145												
 T-144												
 T-143												
 T-141												
Connected external sensor												
Floor sensor												
Outdoor sensor												
Remote sensor												
Connected actuator												
												
Room name												
												



.....

.....

.....









.....

.....

.....

Controller 2

EN

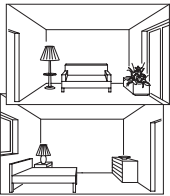
Thermostat	Controller channel						Extension module channel					
	1	2	3	4	5	6	7	8	9	10	11	12
 T-149												
 T-148												
 T-146												
 T-145												
 T-144												
 T-143												
 T-141												
Connected external sensor												
Floor sensor												
Outdoor sensor												
Remote sensor												
Connected actuator												
												
Room name												
												



.....

.....









.....

.....

.....

.....

Controller 3

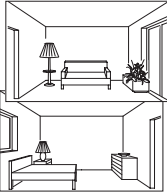
Thermostat	Controller channel						Extension module channel					
	1	2	3	4	5	6	7	8	9	10	11	12
 T-149												
 T-148												
 T-146												
 T-145												
 T-144												
 T-143												
 T-141												
Connected external sensor												
Floor sensor												
Outdoor sensor												
Remote sensor												
Connected actuator												
												
Room name												
												



.....

.....

.....









.....

.....

.....

Controller 4

EN

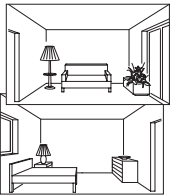
Thermostat	Controller channel						Extension module channel					
	1	2	3	4	5	6	7	8	9	10	11	12
 T-149												
 T-148												
 T-146												
 T-145												
 T-144												
 T-143												
 T-141												
Connected external sensor												
Floor sensor												
Outdoor sensor												
Remote sensor												
Connected actuator												
												
Room name												
												



.....

.....

.....

.....









.....

.....

Controller 5 – 16

Use this page as a template for Smatrix Base PRO controllers 5 – 16

EN

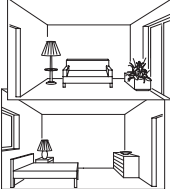
Thermostat	Controller channel						Extension module channel					
	1	2	3	4	5	6	7	8	9	10	11	12
 T-149												
 T-148												
 T-146												
 T-145												
 T-144												
 T-143												
 T-141												
Connected external sensor												
Floor sensor												
Outdoor sensor												
Remote sensor												
Connected actuator												
												
Room name												
												



.....

.....

.....

.....

.....

.....

Uponor

Uponor GmbH

Industriestraße 56,
D-97437 Hassfurt, Germany

1143246 v1_11_2023_EN
Production: Uponor / ELO

Uponor reserves the right to change the product portfolio and the related documentation without prior notification, in line with its policy of continuous improvement and development.



www.uponor.com