

4

3

2

1

F

F

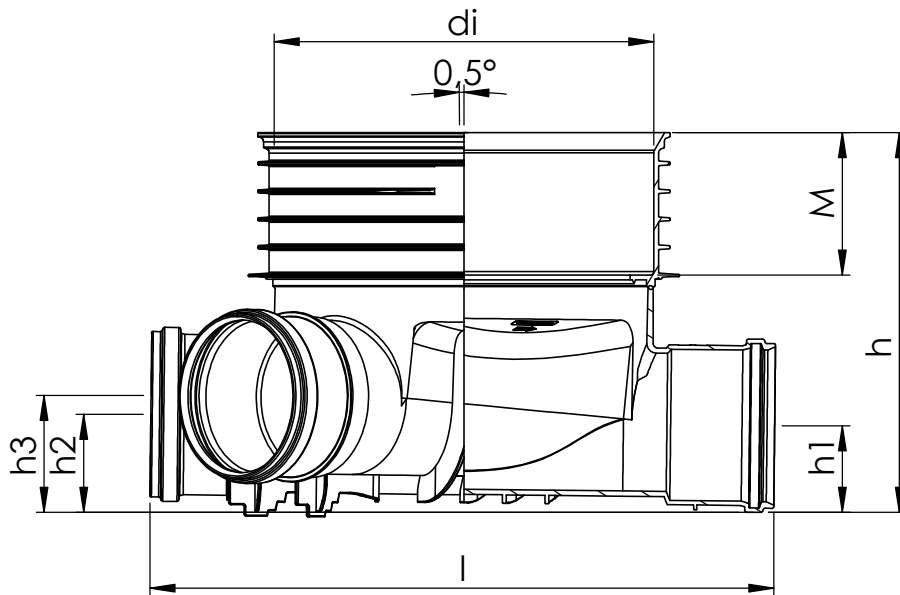

E

E

D

D

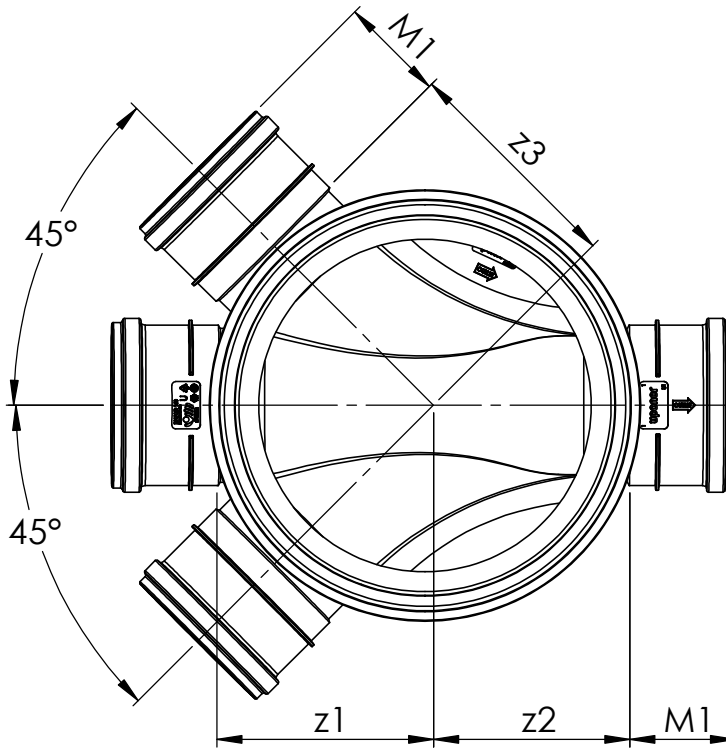

C

C

B

B

Item	Size	di	l	h	h1	h2	h3	M	M1	z1	z2	z3
1086644	400/110	400	546	353	64	79	-	151	59	214	214	213
1086646	400/160	400	660	402	92	97	117	151	112	228	208	242
1086648	400/200	400	710	448	114	121	141	151	129	291	161	273

A

A

Uponor

Description

INFRA
Mounting dimensions
Sewer inspection chamber packages

Drawing number

Z_Sewer_chamber_T2_for_corrugated_riser_110-200

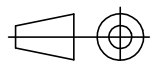

Sheet: 1/1

4

3

2

1