

Combi Port M-Hybrid

EN Installation and operation manual

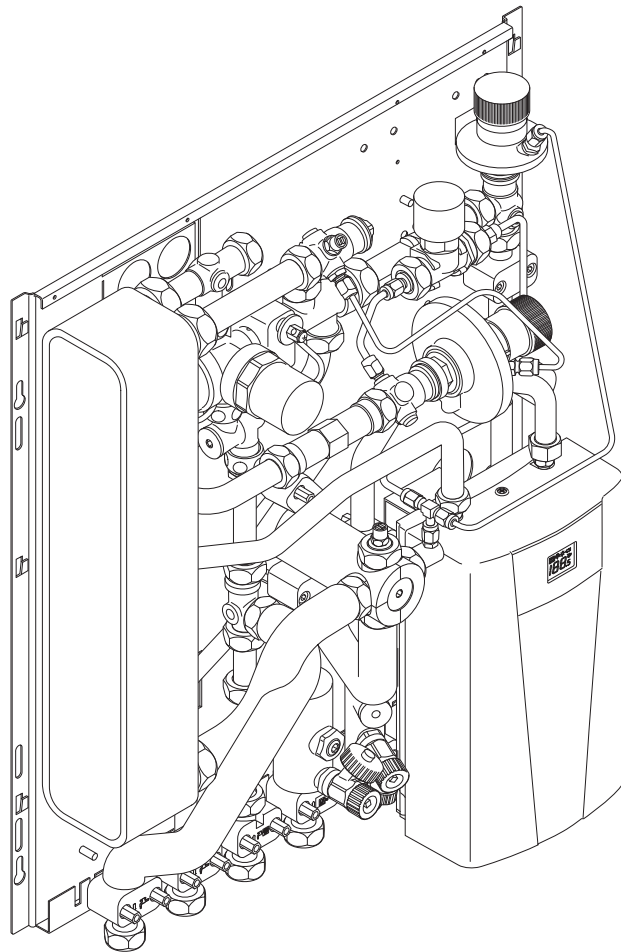

Table of contents

1	Copyright and disclaimer.....	3	8.2	Turning off heat interface unit.....	19
			8.3	Setting log heat interface units.....	20
2	Preface.....	4	9	Troubleshooting.....	21
2.1	Safety instructions.....	4	9.1	Fault description.....	21
2.2	Standards and regulations.....	4			
2.3	Correct disposal of this product (Waste Electrical and Electronic Equipment).....	4	10	Technical data.....	22
3	System description.....	6	10.1	Technical specifications.....	22
3.1	Operating principle.....	6	10.2	Dimensional drawings.....	22
3.2	Connection description.....	6	10.3	Hydraulic schemes.....	22
3.3	Components.....	6	10.4	Performance data.....	23
3.4	Accessories.....	7	11	E-compact instant water heater CEX-U/CEX.....	24
4	Prepare for installation.....	9	11.1	Installation.....	24
4.1	General information.....	9	11.2	Operation.....	33
4.2	Water analysis.....	9			
4.3	Heating side.....	9			
4.4	Drinking water side.....	9			
5	Installation.....	10			
5.1	Mechanical installation.....	10			
5.2	Electrical installation.....	13			
6	Finishing installation.....	14			
6.1	Visual inspection.....	14			
7	Operation.....	15			
7.1	Electric heater.....	15			
7.2	Venting screw.....	15			
7.3	Heat meter distance piece.....	15			
7.4	Strainer.....	15			
7.5	Thermostatic lead module (BP).....	15			
7.6	Differential pressure regulator in secondary heating (standard), Differential pressure regulator in primary heating (optional).....	16			
7.7	Zone valve.....	16			
7.8	Cold water throttle disc.....	17			
7.9	Hydraulic balancing on the manifold.....	17			
7.10	Filling and flushing.....	17			
7.11	Tightness testing.....	18			
7.12	Finishing the installation and hand over.....	18			
8	Maintenance.....	19			
8.1	General information.....	19			

1 Copyright and disclaimer

This is a generic, European-wide document version. The document may show products that are not available in your location for technical, legal, commercial, or other reasons.

For any questions or queries, please visit the local Uponor website or speak to your Uponor representative.

“Uponor” is a registered trademark of Uponor Corporation.

Uponor has prepared this document solely for information purposes, images are only representations of the products. The content (text and images) of the document is protected by worldwide copyright laws and treaty provisions. You agree to comply with these when using the document. Modification or use of any of the content for any other purpose is a violation of Uponor's copyright, trademark, and other proprietary rights.

This disclaimer applies to, but is not limited to, the accuracy, reliability, or correctness of the document.

The presumption for the document is that the product related safety instructions are fully obeyed. The following requirements apply to the Uponor product (including any components) as covered by the document.

- The system (combination of products) is selected and designed by a competent planner. It is installed and put into operation by a licensed and/or competent installer in compliance with the instructions provided by Uponor. Locally applicable building and plumbing codes/regulations have been obeyed.
- Temperatures, pressure and/or voltage limits according to product and design information have not been exceeded.
- The product remains in its originally installed location and is not repaired, replaced, or interfered with, without prior written consent of Uponor.
- The product is connected to potable water supplies or compatible plumbing, heating and/or cooling systems approved or specified by Uponor.
- The product is not connected to or used with third-party products, parts, or components except for those approved or specified by Uponor.
- The product does not show evidence of tampering, mishandling, insufficient maintenance, improper storage, neglect, or accidental damage before installation and being put into operation.

While Uponor has made all effort to ensure that the document is accurate, the company does not guarantee or warrant the accuracy of the information. Uponor reserves the right to change the product portfolio and the related documentation without prior notification, in line with its policy of continuous improvement and development.

Always make sure that the system or product complies with current local standards and regulations. Uponor cannot guarantee the full compliance of the product portfolio and related documents with all local regulations, standards, or working methods.

Uponor disclaims all warranties related to the content of this document, expressed or implied, to the fullest extent permissible unless otherwise agreed or statutory.

Uponor is under no circumstances liable for any indirect, special, incidental, or consequential damage/loss that results from the use or inability to use the product portfolio and related documents.



This disclaimer and any provisions in the document do not limit any statutory rights of consumers.

2 Preface

This installation and operation manual describes how to install and operate the components of the system.





2.1 Safety instructions

Safety messages used in this document

	Warning! Risk of injury and damage. Ignoring warnings can cause personal injury and/or damage to products and other property.
	Caution! Risk of malfunctions. Ignoring cautions can cause the product to not operate as intended.
	Note Important information to the section in the manual.

Uponor uses safety messages in the document to indicate special precautions required for the installation and operation of any Uponor product.

Power

	Warning! Risk of electric shock if touching the components! The unit operates with a 230 V AC voltage.
	Warning! Risk of electrical shock! Electrical installation and service behind secured 230 V AC covers must be carried out under the supervision of a qualified electrician.
	Warning! Uponor system power supply: 230 V AC, 50 Hz. In case of emergency, immediately disconnect the power.
	Warning! Prior to any work on the controller or the components connected to it, switch off the controller according to the regulations.

Technical constraints

	Caution! To avoid interference, keep data cables away from components bearing power of more than 50 V.
---	--

Safety measures

	Note For safe and proper use, obey the instructions given in this document. Keep them for future reference.
---	---

The installer and operator agree to comply with following measures regarding Uponor products:

- Read and obey the instructions and processes in the document.
- The installation must be performed by a qualified installer in accordance with local regulations.
- Uponor is not liable for modifications not specified in this document.
- Switch off all connected power supplies before starting any wiring work.
- Do not expose the Uponor components to flammable vapours or gases.
- Do not use water to clean electrical Uponor products/ components.

Uponor is not liable for damage caused by ignoring the instructions in this document or the applicable building code.

2.2 Standards and regulations

	Note The installation must be carried out in accordance with current local standards and regulations!
---	---

Planning and designing of the heating system must be performed in accordance with applicable global and country-specific standards and guidelines

- Ensure that no aggressive substances, such as acids, lubricants, bleach, flux, strong liquid cleaning agents, contact sprays or concrete including its components, come into contact with the stainless steel manifold and manifold components.
- A water analysis is recommended for each installation. In the event of warranty claims, it is mandatory. It is essential that the heating circuits are regulated on the water side so that a sufficient hydraulic function of the individual heating circuits or the entire underfloor heating system is guaranteed!

For Combi Ports with an assembled water meter, **planning and implementation of the drinking water system** must be done in accordance with the Infection Protection Ordinance.

A few points to be high-lighted:

- Flush and disinfect the system before commissioning and handing over to the user.
- Provide the domestic hot water pipes with required thermal insulation strength.
- Insulate the drinking cold water pipes to secure that no heating in excess of the requirements takes place.

2.3 Correct disposal of this product (Waste Electrical and Electronic Equipment)

	Note Applicable in the European Union and other European countries with waste separation systems.
---	---



This icon on the product, or in the related documents indicates that it should not be disposed with household waste.

Please, recycle responsibly to support the sustainable use of resources and prevent possible harm to human health and/or the environment.

Household users should contact the retailer where they purchased this product, or their local government office, for details on where and how they can take it for recycling.

Business users should contact their supplier and check the terms and conditions of the purchase contract. Do not dispose this product with other commercial waste.

3 System description

Domestic hot water: In the heat interface unit, a comfortable hot water temperature of 45-60 °C is achieved even at low heating flow temperatures of 35-40 °C. Cold water is preheated with a high-performance plate heat exchanger made of stainless steel. Due to the high flow and the low spread of approximately 3-5 °K, the cold water is heated to approximately 37 °C. Reheating to a higher hot water temperature for showering or bathing (approximately 40-60 °C) takes place via the integrated, electric heater (booster).

Domestic heating:

The Combi Port Hybrid units independently manage the hydraulic balancing between hot water and heating. The room temperature

control is carried out in the underfloor heating system (pump group, thermostatic supply temperature valve, room thermostat).

The heat interface unit is available for on-wall installation only.

Hygienic principle:

The heating water flows through the heat exchanger only on demand. This ensures a constant hot water temperature. If no hot water is needed, the valve stops the supply of hot water through the heat exchanger. It can cool down which is beneficial for the hygiene.

3.1 Operating principle

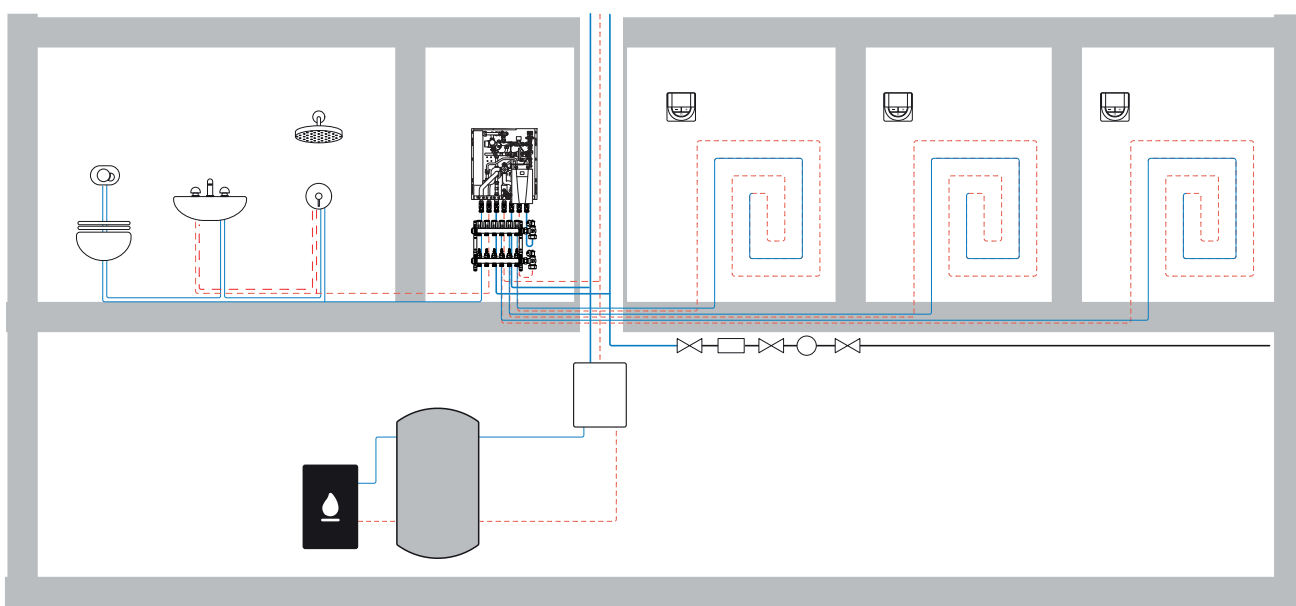

SD0000373

3.2 Connection description

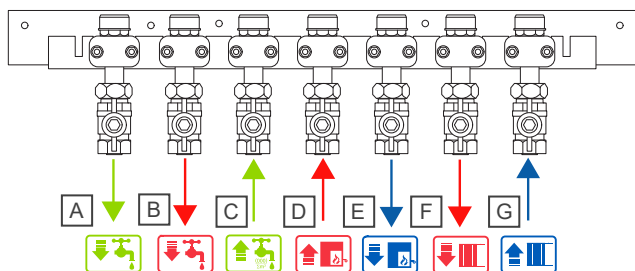

SD0000372

Item	Description
A	Cold water to apartment (PWC)
B	Domestic hot water to apartment (PWH)
C	Cold water from riser (PWC)
D	Heating supply (primary)
E	Heating return (primary)
F	Heating supply (secondary)
G	Heating return (secondary)

3.3 Components

Note
The following illustrations show example set-ups. Individual modules may vary in appearances.

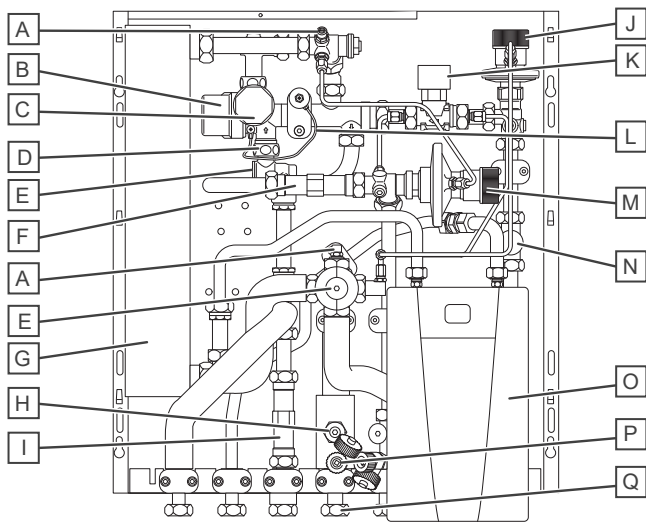

SD0000374

Item	Description
A	Air vent
B	PM controller
C	Water hammer arrester
D	Cold water restrictor 10 l/min (in connection)
E	Strainer
F	Heat meter distance piece
G	Heat exchanger
H	Heat meter pocket M10 x 1
I	Water distance piece
J	Differential pressure regulator in secondary heating
K	Thermostatic lead module (BP)
L	Potential equalization
M	Differential pressure regulator in primary heating
N	Zone valve to limit heating supply to apartment
O	Electric heater (booster)
P	Drain valve
Q	Swivel G $\frac{3}{4}$ " with flat gasket

Cabinets including manifolds

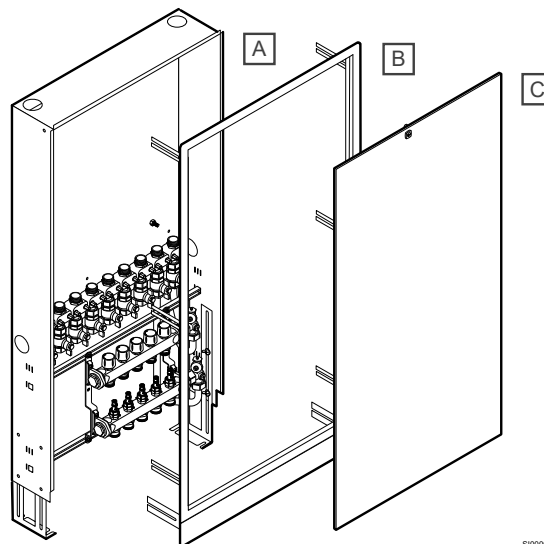

SI0000295

Item	Description
A	Cabinet body
B	Frame
C	Door

Cabinets include pre-installed ball-valve rail and underfloor heating (UFH) manifolds 4 - 12 loops.

Dimensions of in-wall cabinet (width x height x depth) in mm

810 x 1200 x 180, with UFH manifold 4-12 loops

Room temperature control



Note

Thermostats and remote control modules are not part of the Uponor Combi Port delivery. They must be ordered separately.

Uponor Smatrix

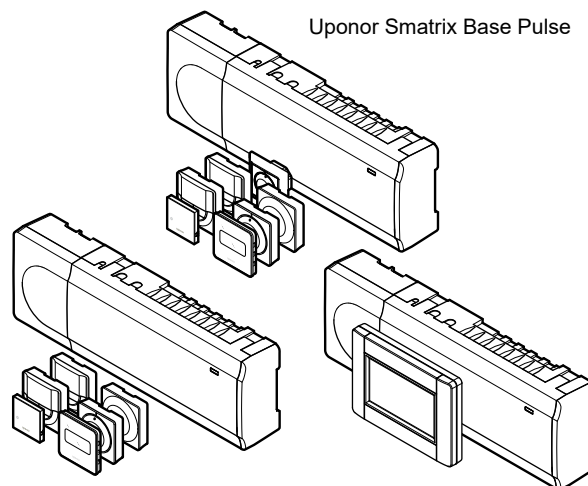

Uponor Smatrix Base Pulse Uponor Smatrix Wave Pulse Uponor Smatrix Base PRO

CO0000271

3.4 Accessories

Uponor offers a variety of accessories that are compatible with the standard portfolio. The following accessories are optional, and their use completes the product portfolio. Subsequent chapters describe the application in more detail.

Uponor Smatrix is a fully equipped range of components for room temperature control, optionally via radio or wired. The unique auto-balancing technology eliminates the need for manual balancing of the loops. The smart system accurately determines and controls the exact energy needed for an optimal room temperature. The result is

highly comfortable underfloor heating and cooling with reduced energy consumption.

Room control functions

This list shows available functions for the different systems.

Basic functions	Wave Pulse	Base Pulse	Base PRO
Autobalancing	✓	✓	✓
Cooling function	✓	✓	✓
Modularity	✓	✓	✓
Installation and configuration functions	Wave Pulse	Base Pulse	Base PRO
Installation wizard	✓	✓	
Offline configuration	✓	✓	
Over-the-air updates	✓	✓	
Remote support	✓	✓	
Comfort functions	Wave Pulse	Base Pulse	Base PRO
Mobile app	✓	✓	
Smart notifications	✓	✓	
Trend visualization	✓	✓	✓
Multi home control	✓	✓	
Smart home integration	✓	✓	
Comfort settings	✓	✓	✓
ECO profiles	✓	✓	✓
Electrical underfloor heating control	✓	✓	
Ventilation integration	✓	✓	
Fan coil integration	✓		
Technical functions	Wave Pulse	Base Pulse	Base PRO
Uponor cloud services	✓	✓	
Data storage	✓	✓	✓
Pump management	✓	✓	✓
System diagnostics	✓	✓	✓
Heat pump (HP) integration	✓*)	✓*)	✓
Room bypass	✓	✓	✓
Room check			✓
KNX BMS integration			✓
Modbus RTU BMS integration			✓

*) cloud connectivity with selected HP for dynamic heat curve adjustment

Uponor Base flexiboard

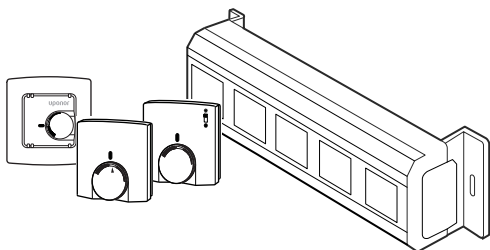

CD0000270

Uponor Base flexiboard is a 230 V control that enables individual room control for 6 or 8 rooms. There are also 2 variants with integrated pump logic available. This switches the circulating pump on or off as required and enables an energy-efficient operation.

Uponor Base X-60 and X-80

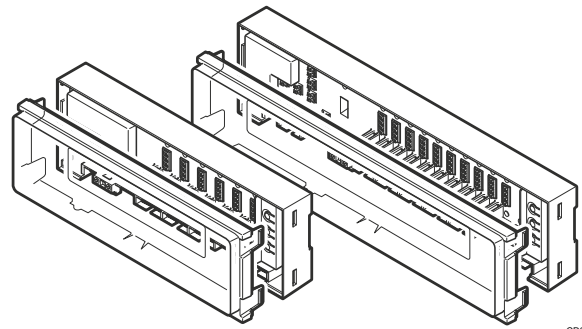

CD0000623

Uponor Base X-60 and X-80 are control units with autobalance function for 230V standard wiring:

- Base X-60 supports up to 6 thermostats and 12 actuators 230V.
- Base X-80 supports up to 10 thermostats and 12 actuators 230V (also for cooling applications).

Available functions

This list shows available functions for the different systems.

Basic functions	X-80	X-60
Autobalancing	✓	✓
Time limit by-pass with autobalance	✓	✓
Heating/cooling switch	✓	
Input: condensation	✓	
Input: day/night switch	✓	✓
Technical functions	X-80	X-60
Pump relay	✓	✓
Boiler relay	✓	
Four wires thermostat connection	✓	✓
Works with three wires thermostat	✓	

Additional information



Note

Visit the Uponor download centre for more information regarding the installation and configuration of Uponor Smatrix and Uponor Base flexiboard.





Uponor Smatrix and Base controllers



www.uponor.com/services/download-centre

4 Prepare for installation

4.1 General information

	Warning! The fittings are under pressure. Escaping pressurized media can cause serious injury such as scalding or eye damage. Depressurise the system before performing any installation work. For retrofits to an existing system: Drain the system or close the supply lines of the section and depressurise it.
	Warning! Risk of injury due to the heavy weight of the unit: Do not perform the installation alone. Always wear safety shoes during the assembly. The unit can be of considerable weight, depending on the configuration. If the station falls over, this could lead to injuries, particularly to the feet.
	Caution! Leaks in the unit may occur during transport or installation. Check the nuts to ensure that they are properly tightened before the connection to avoid property damages.

Before installing the heat interface unit ensure that:

- the primary pipes are laid in the building site.
- the primary pipe installation is flushed and checked for leaks.
- the power and ground cables are routed to the installation site.
- the unit can be installed in a dry and frost-free room with an ambient temperature lower than +40 °C.
- the unit can be installed upright (not inclined, upside down or lying down).
- the unit is always easy to access even after the assembly.

4.2 Water analysis

A water analysis of the tap water must be checked before using the device. The limit values of domestic and heating water must be considered. The heating water quality must be in accordance to VDI 2035.

4.3 Heating side

The heating water quality must be in accordance to VDI 2035.

4.4 Drinking water side

The brazed plate heat exchangers are made up of embossed stainless steel plates (1.4404/1.4401 or SA240 316L/SA240 316). Thus, it is necessary to consider the corrosion behaviour of both the stainless steel and the Vaclnox solder.

The heat exchangers in the heat interface units are made up of Vaclnox stainless steel plates. Before using the heat exchangers, the building services planner or installation company must check during system planning that corrosion protection and scale formation have been adequately addressed in accordance to local regulations (e.g.,

DIN 1988-200 paragraph 12.3.2) and the available drinking water analyses. This verification must cover the following points:

- Selection of material.
- Corrosion-related changes in drinking water quality.
- Execution of the installation.
- Consideration of the anticipated operating conditions.

The below values for water ingredients must be fully obeyed:

Water ingredients	Value	Heat exchanger Vaclnox soldered
pH-value	-	6-10
Total Hardness	°dH	6-15
Filterable substances	mg/l	<30
Chloride	mg/l	See list 1)
Free chlorine	mg/l	<0,5
Sulfate	mg/l	<400
Sulfide	mg/l	<7
Iron dissolved	mg/l	<0,2

1)

- At 20 °C max. 800 mg/l
- At 25 °C max. 600 mg/l
- At 50 °C max. 200 mg/l.

5 Installation

5.1 Mechanical installation

In-wall installation

Preparations

Note
For dimensions, refer to Chapter 10.2, Dimensional drawings.

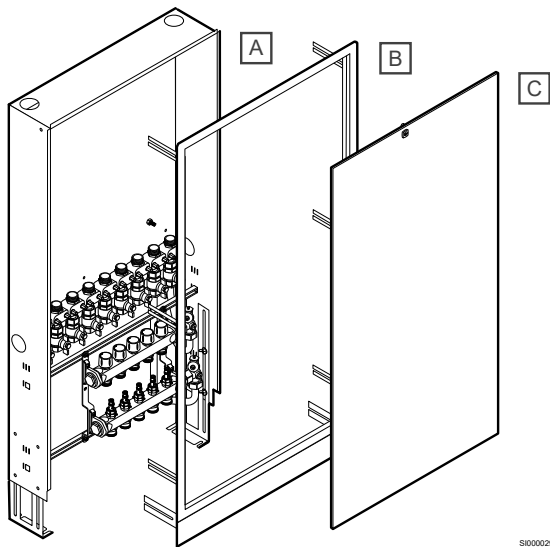

Item	Description
A	Cabinet body
B	Frame
C	Door

1. Dismount the frame and door.
2. Store the frame and door for later mounting.

Adjusting the in-wall cabinet

The in-wall cabinets are adjustable inside the recess in height and depth.

The recess height is calculated using the floor height and is measured from the bare floor. The specified floor installation height has to be set according to the values visible on the feet.

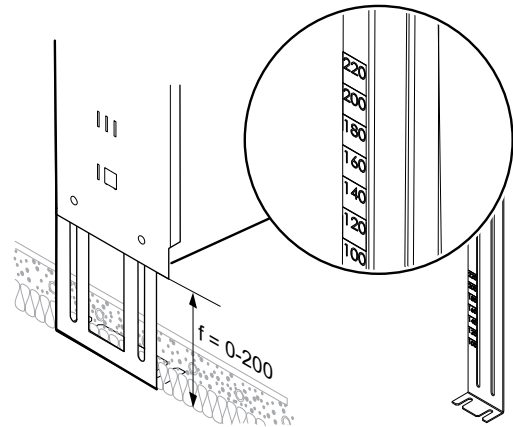

Dimensions of in-wall mounted cabinet (width x height x depth mm)	Recess dimensions in-wall (width x height x depth mm)
810 x 1200 x 180 ¹⁾	(810 + 45) x (1200 + 30 + f) x 185 ¹⁾

1) With pulled out cabinet frame.

Install the in-wall cabinet

Note
For freestanding installations, set the height according to the table and adjust the feet accordingly. Pay attention to the horizontal alignment.

1. Mark the hole positions in the wall recess. Use the in-wall cabinet holes as a pattern.
2. Level up horizontally.

3. Adjust the depth of the cabinet body.

Caution!
Adjust the depth to 180 mm.

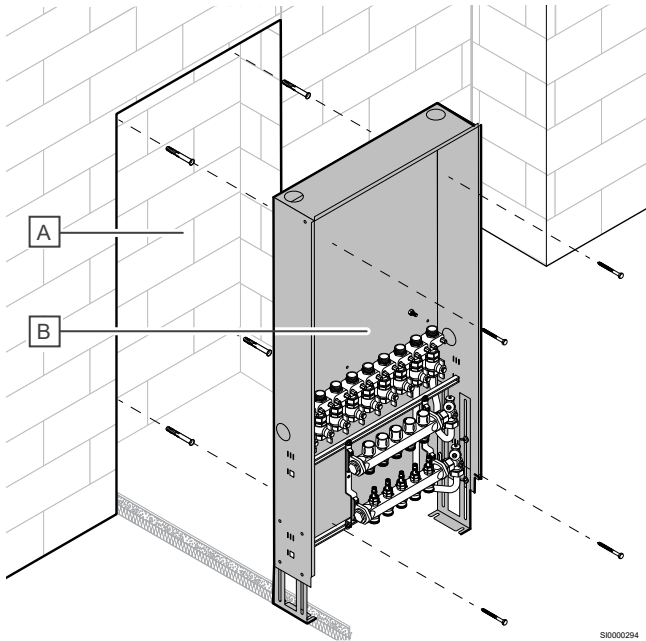

SI0000294

Item	Description
A	Wall recess
B	In-wall mounted cabinet

4. Drill holes suitable for the plug.
5. Mount the enclosed plugs in the drilled holes and place the in-wall box in the wall recess.

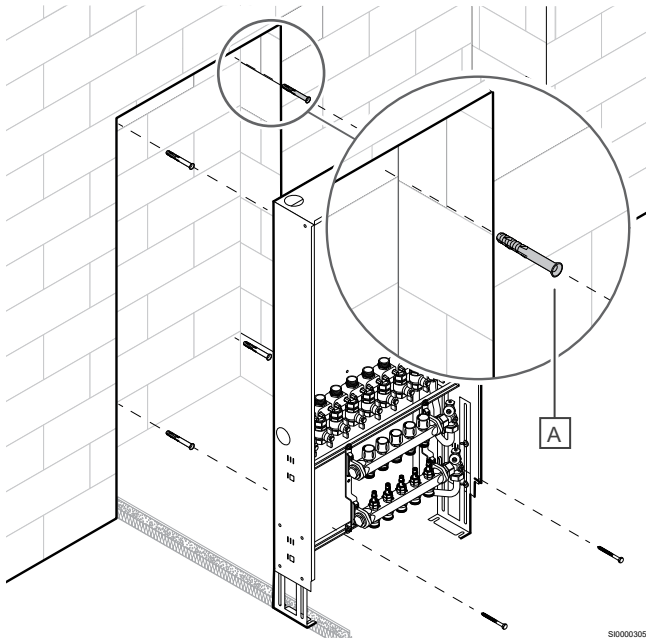

SI0000305

Item	Description
A	Wall plug (4 pcs)

6. Secure the in-wall mounting box to the wall recess, and secure with the enclosed hexagon bolts.

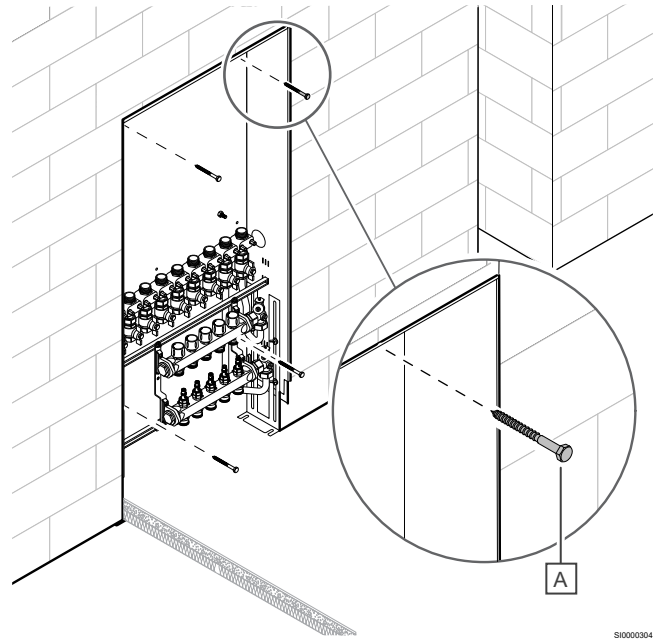

SI0000304

Item	Description
A	Hexagon bolt (4 pcs)

Connecting the primary supply pipes

- Note**
Install the pipes in accordance with the planning documentation.
- Note**
Make sure that the pipe insulation and fixing are made in accordance with local regulations.

1. Use the desired fittings to connect the supply pipes to the ball valves.

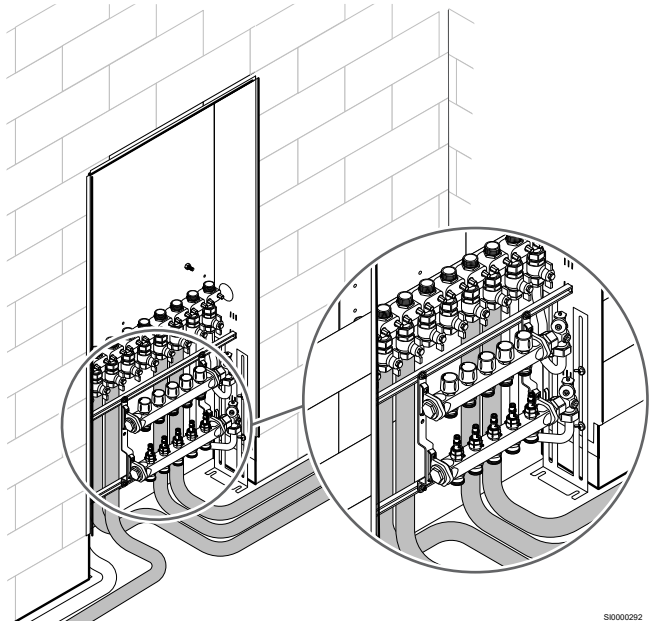

SI0000292

Install the heat interface unit

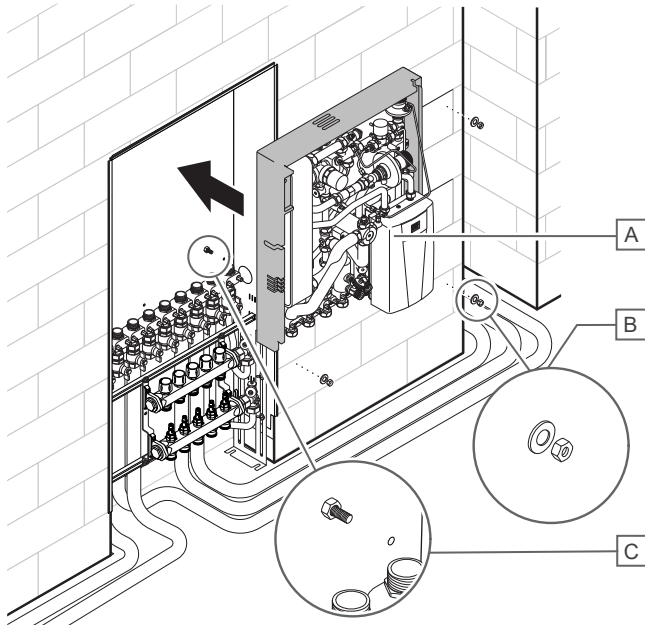

Item	Description
A	Heat interface unit
B	Hexagon nut (4 pcs)
C	Fixed bolts

1. Mount the heat interface unit on the fixed bolts in the cabinet wall.
2. Tighten with 4 hexagon nuts.
3. Place the flat gaskets on to the connection rail $\frac{3}{4}$ " screw connection.

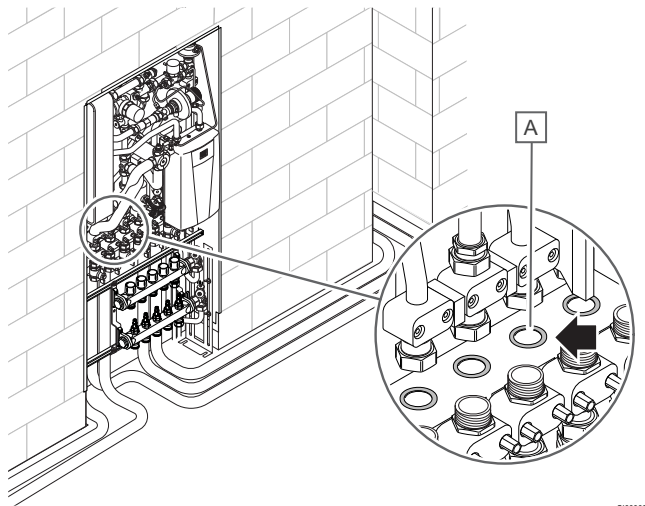

Item	Description
A	Flat gasket

Note

Check the flat gasket/-s for damage.

4. Tighten the $\frac{3}{4}$ " swivel nuts.

Connecting the pipes



Note

Install the pipes in accordance with the planning documentation.



Note

Ensure the use of supplied seals when connecting the pipes!

Connect the underfloor heating pipes to the manifold.

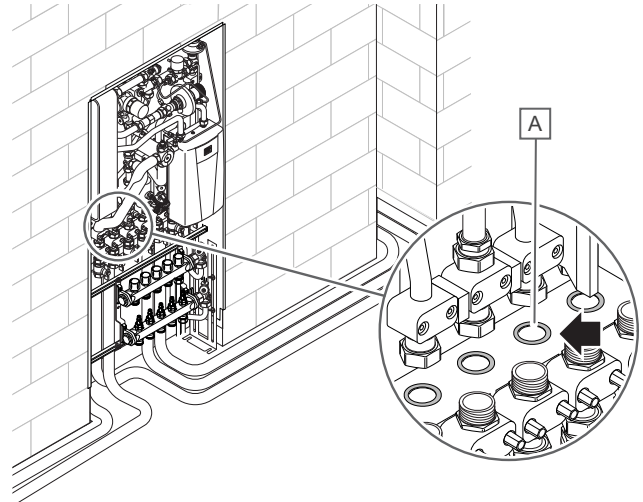

1. Cut the pipe to the required length.
2. Connect the pipe to the manifold with the compression fitting.



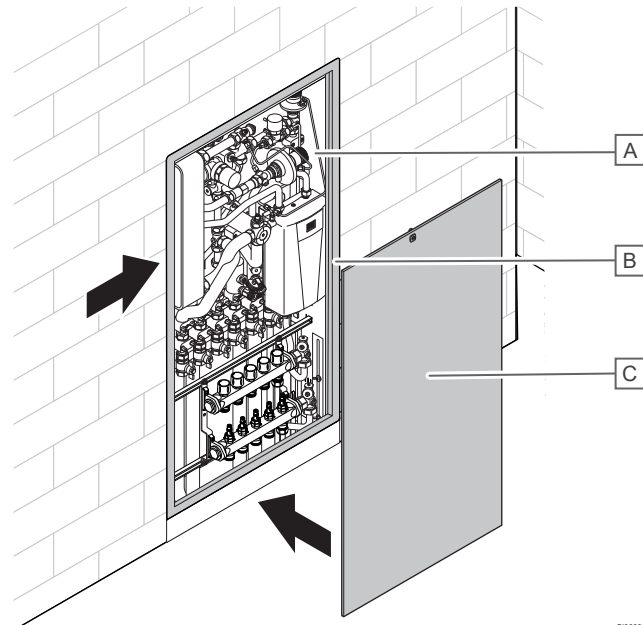

Install the frame and door to the cabinet



Item	Description
A	In-wall cabinet
B	Frame
C	Door

1. Close the heat interface unit with an insulation cover.
2. Attach the frame to the cabinet body using wing nuts.
3. Mount the door in the frame by fitting the two frame brackets into the recesses in the door.

5.2 Electrical installation

	Warning! Risk of electric shock if touching the components! The unit operates with a 400 V AC (electric heater), 230 V AC (control unit) voltage.
	Warning! Required work must be performed by a qualified installer in accordance with local regulations. This includes electrical connections and installations, set up for operation and maintenance.
	Warning! Upon system power supply: 400 V AC (electric heater), 230 V AC (control unit). In case of emergency, immediately disconnect the power.
	Note For more information on electrical installation instructions, please refer to chapter 11. E-compact instant water heater CEX4-U in this document.

6 Finishing installation

	Warning! Leaks can cause personal injury and property damages.
---	--

	Note Install the pipes in accordance with the planning documentation.
---	---

To ensure proper functionality for the heating system, do not reduce the specified cable cross-sections. Replace the heat meter distance piece with the heat meter.

If a plastic distance piece are not to be replaced with an optional component, replace it with stainless steel **1.4401** pipes. Contact manufacturer for more information.

- Connect the hydraulics correctly.
- When connecting the pipes, use the supplied gaskets.
- Connect the heating supply, heating return and the hot and cold water.
- Install a filling and draining valve on site at a suitable central point to fill the central heating system.
- Refer to the planning documentation for installation instructions.

6.1 Visual inspection

	Caution! Incorrect finishing of the installation can lead to property damage.
---	---

	Note If an installation error is found during visual inspection, temporarily stop and correct the error.
---	--

Follow these steps to finish the installation:

1. Examine the complete installation:
 - 1.1. Make sure that the hydraulics are connected correctly.
 - 1.2. Make sure that any dirt accumulated during installation and/or dust on the unit has been removed. Examine the strainers and, if necessary, flush/clean them.
 - 1.3. Examine the tightness of all gaskets on pipe and device connections and tighten them if necessary. When tightening connections, always lock the opposite side.
 - 1.4. Optional: Make sure that all electrical connections are correct, including the polarity of the mains connection. Make sure that the system is correctly earthed.
2. Make sure that the installation is filled/flushed and vented.

7 Operation

7.1 Electric heater



Note

For more information on electric heater, please refer to chapter 11. **E-compact instant water heater CEX4-U** in this document.

7.2 Venting screw

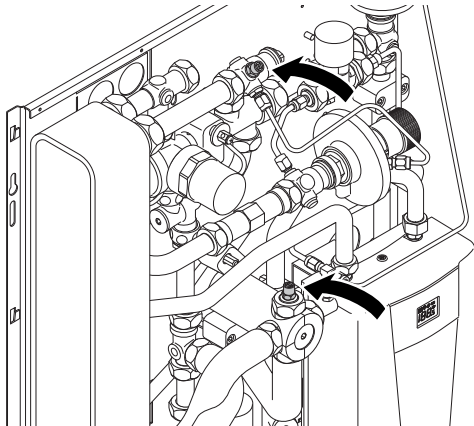

CD0000762

Vent the heat interface unit at the venting screws.

7.3 Heat meter distance piece



Note

The heat meter to be installed must have these specifications: **Qn = 1,5 m³/h**, with fast scanning frequency of 1,5-2 seconds, that fully measures the volume flow rate every 3-4 seconds, including kWh calculation. We recommend to use an ultrasonic heat meter. Construction length of **110 mm** and **3/4"** external threaded connection.



Note

The heat meter distance piece is not suitable for continuous operation.

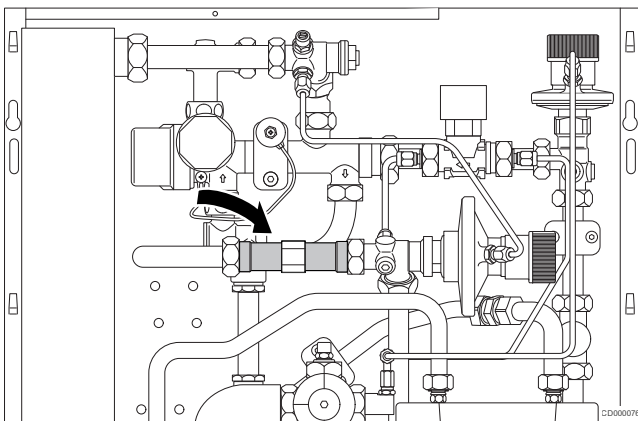

CD0000761

The heat meter distance piece is intended to be replaced with a heat meter to record energy consumption. A sensor pocket for M10 x 1 mm is available for the flow sensor.

7.4 Strainer



Caution!

Shut off the water supply, primary and secondary heating to the unit and relieve the pressure before any work with the strainer.



Note

To open the strainer, use an internal hexagon (**6 mm**).

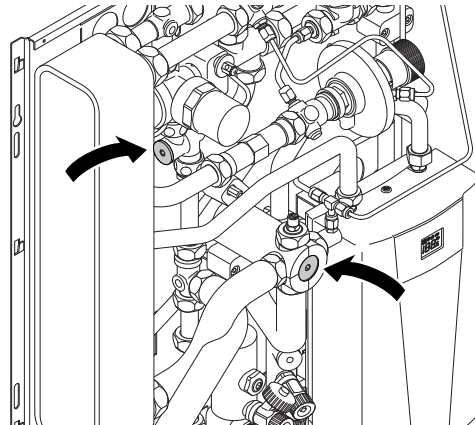

CD0000760

The strainer collects dirt and its filter can be removed for inspection and cleaning.

7.5 Thermostatic lead module (BP)



Note

A too high temperature setting can cause the heating water return temperature to rise.



Note

A too low temperature setting can lead to longer waiting times when preparing domestic hot water.

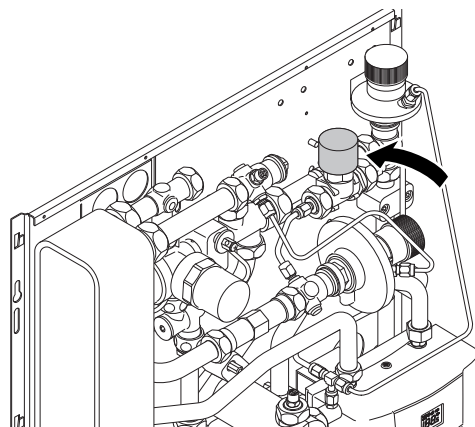

CD0000763

A thermostatic lead module (BP) is used to prevent the risers from cooling down when not dispensing.

1. Set the BP line temperature to approximately **15 K** below the heating supply temperature using the handwheel, with a range 35-60 °C. Refer to **Chapter 8.3, Setting log** for the default settings.

7.6 Differential pressure regulator in secondary heating (standard), Differential pressure regulator in primary heating (optional)

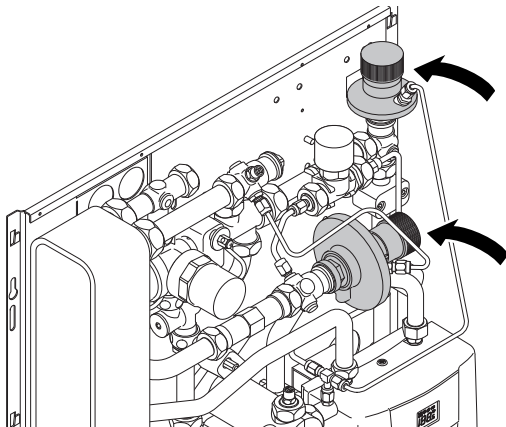

CD0000766

The differential pressure regulator protects other control valves, such as the proportional volume control or the radiator valves, from the excessive differential pressure and ensures the hydraulic balancing of the installation. The differential pressure regulator works independently and without auxiliary energy and is adjustable from the outside.

Turn the handwheel to continuously adjust the desired setpoint for two regulators which are used in the heat interface unit:

- Setting range differential pressure regulator (secondary heating) 50-300 bar (refer to **Chapter 8.3, Setting log** for the default settings).
- Setting range differential pressure regulator (primary heating) 100-400 bar (refer to **Chapter 8.3, Setting log** for the default settings).

7.7 Zone valve



Note

It is possible to change the valve setting during operation without leakage.

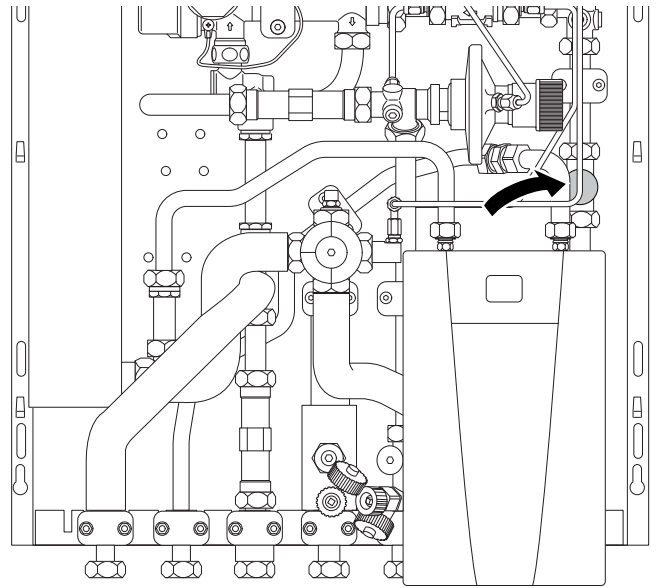

CD0000767

The mass flux in the secondary heating circuit can be regulated with the zone valve. The housing of this valve has a threaded connection (**30 x 1,5**) for a 2-point actuator.

Adjust the value using a 13 mm hexagonal key, within the range of 1-9 (refer to **Chapter 8.3, Setting log** for the default settings).

Actuator on the zone valve

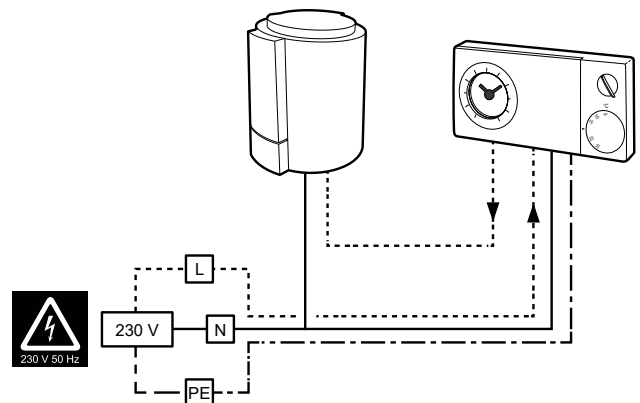

CD0000260

The thermal actuator is installed on the zone valve and is controlled by a room thermostat. All users can set the required room temperature here including night-time reduction.

Follow country-specific regulations for user-oriented room control.

Description	Value
Operating voltage	230 V AC, 50/60 Hz
Operating line	1 W
Line	2 x 0,75 mm ² (1x Blue / 1x Brown)

7.8 Cold water throttle disc

Note

The installed cold water throttle disc can be replaced if required. The colour indicates the maximum volume flow (see table below).

The cold water throttle disc is in the connection between the cold water connection of the proportional volume control and the strainer.

The throttle disc limits the amount of cold water to the heat exchanger and prevents the hot water supply from exceeding the calculated volume.

Cold water throttle disc colour	l/min
Black	6
White	8
Orange	9
Blue	10
Red	12
Green	15
Brown	17
Black	19
Purple	22

Replacing the throttle disc

Note

Observe the flow direction when replacing the throttle disc!

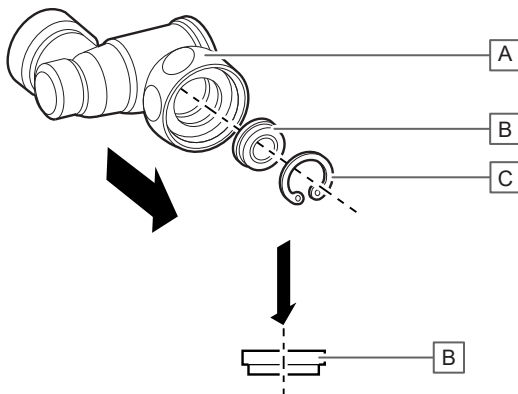

Item	Description
A	Strainer
B	Cold water throttle disc
C	Retaining ring

1. Disassemble the strainer.
2. Disassemble the retaining ring. Use special pliers for this.
3. Replace the throttle disc.
4. Install the retaining ring.
5. Install the strainer.

7.9 Hydraulic balancing on the manifold



Warning!

The pressure in the valves can cause personal injury.

Uponor floor heating calculations
 Uponor Fußbodenheizungsrechnung
 Uponor vloerverwarmingberekening
 Calculacion du chauffage par le sol Uponor
 Calcolo riscaldamento a pannelli radianti Uponor

Room heating circuit data			
Ruimte- en verwarmingsgroepgegevens	Ruimteno.	Verwarmingsgroep	Verwarmingsoppervlakte
Données des pièces - circuits de chauffage	N° de la pièce	N° du circuit de chauffage	Surface de la surface
Dati circuito riscaldamento locale	Numero circuito riscaldamento locale	Quantità di acqua	Valvole regolazione
		l/min	Struttura delle valvole
1	1	2	0,5
1	2	5	3
2	3	2	1
3	4	4	4
4	5	1,5	2

1. Unlock the flowmeter. Pull the outer ring approximately 6 mm up.
2. Set the flowmeter to the system flow rate (l/min). Set each heating loop obeying the system calculation.
3. Mark the setting with the memory ring.
4. Lock the flowmeter. Push the outer ring down.

7.10 Filling and flushing

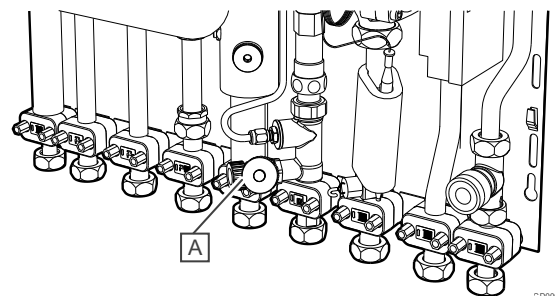



The filling and draining valve (A) on the heat interface unit is used to fill and flush the system.

Filling and flushing the system

1. Open the draining valve (A).
2. Fill and flush the system with heating water as per VDI 2035, or follow country specific regulations.

7.11 Tightness testing

	Warning! Leaks can cause personal injury and property damage.
	Caution! Pressure leaks can occur even at normal operating pressure and must be repaired immediately.

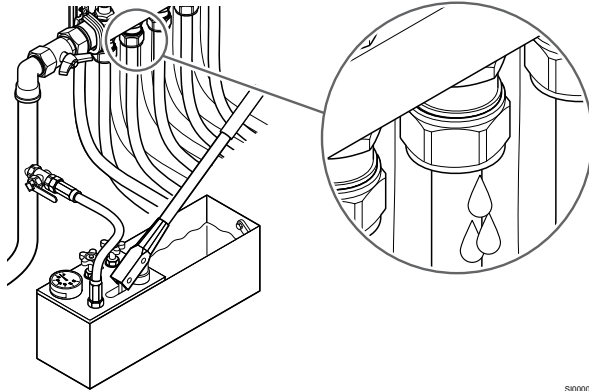

S0000622

The tightness test for heating and domestic water installations must obey country-specific regulations.

7.12 Finishing the installation and hand over

	Caution! Incorrect finishing of the installation can lead to property damage.
---	---

Do these steps to finish the installation:

1. Do a check of the settings.
2. Complete the acceptance/finishing protocol and describe the adjusted settings as detailed in **Chapter 8.3, Setting Log**.
3. Hand over the documentation and the protocol to the homeowner.

8 Maintenance

8.1 General information

Important information

To ensure the correct and safe operation of the system, this information must be read and followed.

Following these instructions will help avoid hazards and downtime and increase the reliability and life of the system.

A visual inspection of the port unit is required every 3 to 6 months.

Function and energy savings

The heat interface unit is a compact station that can operate in a system with several units or as a supplement to an existing heating system. It is designed for residential buildings and is used to supply, control and measure domestic cold water (PWC), domestic hot water (PWH) and space heating.

Hot water is only prepared on demand and not stored, which is the most convenient and hygienic way. This enables dispensing of large amounts of hot water. Restrictions are only imposed by the central heating.

Water heating

	Caution! All water pipes are filled and pressurised.
---	--

The cold water supply for the apartment is provided via the central house connection and distribution line.

The heat interface unit is equipped with a central shut-off ball valve for cold water (C).

All ball valves should be exercised (open-close) at regular intervals (about once per month).

The ball valves (A) and (B) should only be closed for assembly/disassembly reasons.

Water hygiene

Although the water system follows the flow principle, which is the most hygienic method of water heating, the water pipes should always be flushed if not used for a longer period.

The tapping duration should be around 1-2 minutes. The water must be allowed to run at least every 7 days for about 1-2 minutes (follow country specific regulations).

8.2 Turning off heat interface unit

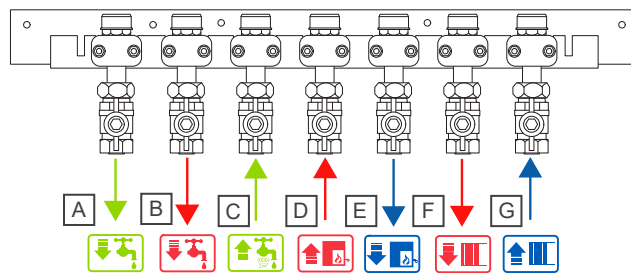

SD0000372

Ball valves C, D and E must be closed in the event of a malfunction.

Item	Description
A	Cold water to apartment (PWC)
B	Domestic hot water to apartment (PWH)
C	Cold water from riser (PWC)
D	Heating supply (primary)
E	Heating return (primary)
F	Heating supply (secondary)
G	Heating return (secondary)

If the system is to be shut down for a longer period:

1. Shut off the cold water tap (C). Do not close ball valves D, E, F and G.
2. Protect the heat interface unit against frost.
3. When restart, let the hot water run for about five minutes (follow country specific regulations).

8.3 Setting log heat interface units

Date:		Setting log heat interface units				
Site:		Type:		Serial no:		
Component	Description			Setting range	Factory setting	Set on site
BP	Thermostatic lead module, capillary 6 mm, Kvs 1,55			35-60 °C	45 °C	
DI	Differential pressure regulator in secondary heating			50-300 mbar	100 mbar	
DI	Differential pressure regulator in primary heating (option)			50-400 mbar	200 mbar	
Component	Description			Type		
Cold water throttle disc	Colour	Green		Black		
	Max. flow l/min	15		19		
Exchanger	Type	GKE-228H-24 (CU)		GKE-228H-40 (CU)		
		DW GVH-228H-24 (Vaclnox)		DW GVH-228H-40 (Vaclnox)		
Heat meter distance piece	Heat meter line Qn 1,5 installation length, 110 mm x ¾"					

9 Troubleshooting

9.1 Fault description

Fault description	Cause	Solution
Hot water function		
Hot water temperature too low or fluctuating	Central heating	
	Heating circuit pump type not supported	Check the central heating pump
	Setting for heating circuit pump is not correct	Heating circuit pump setting: Constant pressure
	Pump performance too low	Check the pump performance
	Mixing valve faulty	Check the mixing valve function
	Setting for heating circuit control is not correct	Check the heating circuit control setting
	Heating circuit control faulty	Check the heating control function
	Air trapped in buffer storage	Vent buffer storage tank
	Cold water pressure too low/too high	Cold water pressure at unit: Min. 3-3,5 bar
	Heat interface unit	
	Strainer in primary flow dirty	Clean the strainer in the primary flow
	Insufficient differential pressure	Clean the capillary of the differential pressure control and check that the differential pressure control is working
	Air in the system	Vent the system while dispensing
	Insufficient heating volume flow passes through the heat exchanger	Check the volume flow using heat meters
	Heat meter type not supported	Use heat meter type with Qn 1,5
	Insufficient heating volume flow	Increase differential pressure
Heat exchanger dirty	Clean the heat exchanger	
Proportional volume control does not switch over	Replace the proportional volume control	
Ball valves closed	Check if ball valves in open position	
Waiting time for hot water is too long	Check the pump setting in the central heating system	Pump setting: Constant pressure
	The temperature setting on the thermostatic lead module (BP) is too low	Increase the temperature setting on the thermostatic lead module (BP)
	The capillary on the thermostatic lead module (BP) is dirty	Clean the capillary on the thermostatic lead module (BP)
	No thermostatic lead module (BP) available	Retrofit the thermostatic lead module (BP)
Noise generation		
Noise generated in the station	Pipe clamps too tight	Check the pipe clamps
	Cold-water throttle disc is dirty	Clean the cold-water throttle disc
Heating function		
Heating system does not heat up	Supply temperature too low at the heat source	Check the supply temperature at the heat source
	Volumetric flow rate is too low	Check the fittings in the device
	Check the heat meter type	The heat meter type must be Qn 1,5
	Check the pump setting in the central heating system	Pump setting: Constant pressure
	Air trapped in buffer storage	Vent the buffer storage tank
	Insufficient differential pressure	Clean the capillary of the differential pressure control and check that the differential pressure control is working
	Air in the system	Vent the system
Underfloor heating not working well	Actuators on manifolds not or wrong connected	Check electrical connection of actuators Check connection-order to the room-thermostats
	Room temperature too low / too high	Check temperature setting on room-thermostats Check if manifold presetting done. You see the flows on the flowmeters mounted at the manifold. When needed, check the presetting.

10 Technical data

10.1 Technical specifications

Caution!

Electrical installation and servicing involving secured voltages of 400 V AC (electric heater) and 230 V AC (control unit) must be performed by a qualified electrician. Please refer to Chapter 11. E-compact instant water heater models CEX-U/CEX.

HIU	Value
Medium	Heating water according to VDI 2035
Operating temperature	5-85 °C
Max. operating pressure	10 bar
Pressure drop heating primary	0,6 bar
Min. tap water pressure required to comply with the tap water supplier's standards	3,0 bar

Material	Value
Fittings, Tap water	CW617N
Fittings, Heating	CW617N, CW614N
Seals	According to DVGW KTW, W270
Plate heat exchanger	1.4404
Pipes	1.4401
Weight	approximately 14 - 16 kg

10.2 Dimensional drawings

Note

The following illustrations show example set-ups. Individual modules may vary in appearances.

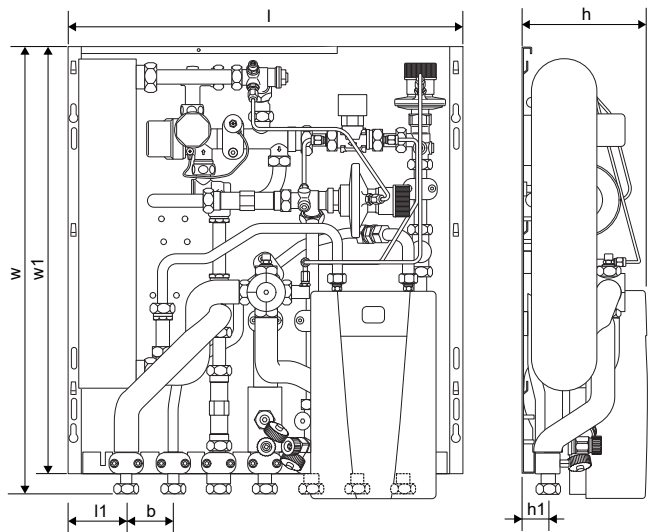

l	l1	b	w	w1	h	h1
556 mm	83 mm	65 mm	617 mm	600 mm	179 mm	39 mm

10.3 Hydraulic schemes

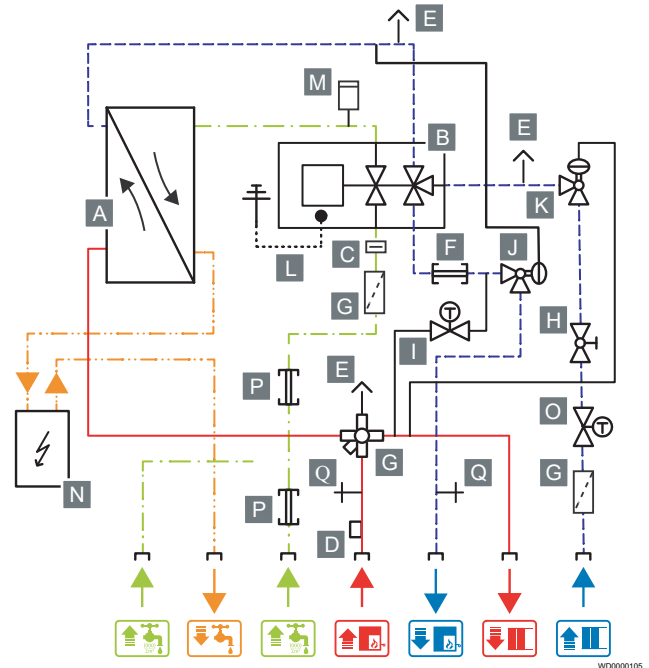

Item	Description
A	Heat exchanger
B	PM controller
C	Cold water restrictor 10 l/min (in connection)
D	Heat meter pocket M10 x 1
E	Air vent
F	Heat meter distance piece
G	Strainer
H	Zone valve to limit heating supply to apartment
I	Thermostatic lead module (BP)
J	Differential pressure regulator in primary heating
K	Differential pressure regulator in secondary heating
L	Potential equalization
M	Water hammer arrester
N	Electric heater (booster)
O	Return temperature limiter (RL) (option)
P	Water distance piece
Q	Fill and drain valve

10.4 Performance data

Heating side (primary)

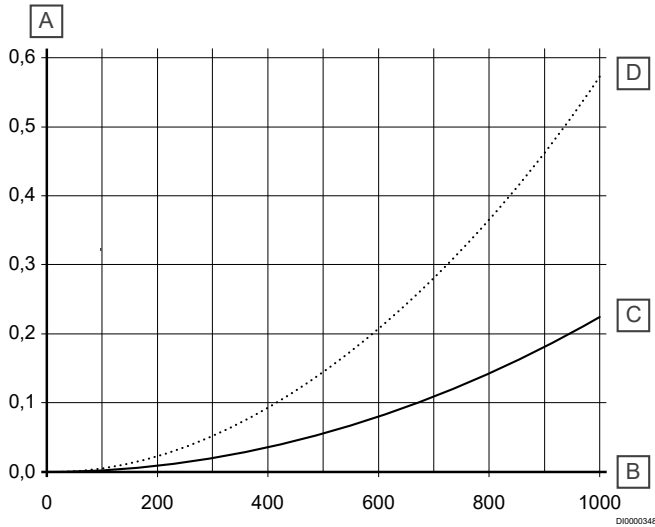

Item	Description
A	Pressure drop in bar
B	Heating water flow rate in litres/hour (l/h)
C	Without differential pressure regulator
D	With differential pressure regulator in primary heating

Pressure drops including ball valve. Additional pressure drops, e.g. heatmeter with $Q_n 1,5$ of approximately **0,05 bar** and other installations must be included.

Sanitary site (secondary)

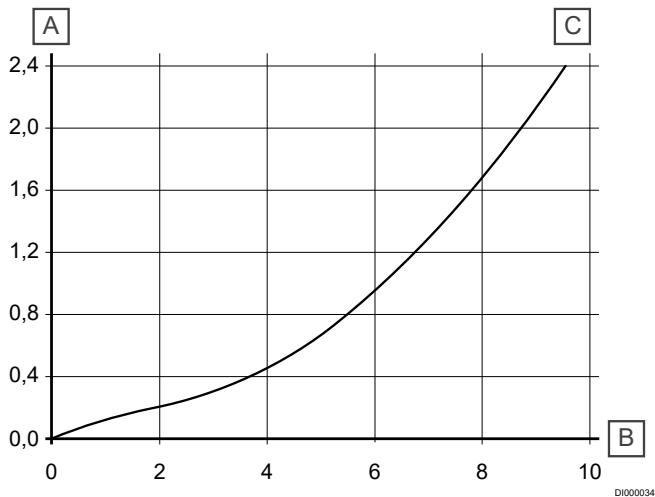

Item	Description
A	Pressure drop in bar
B	Tap water flow rate in litres/minute (l/min)
C	Without differential pressure regulator

Pressure drops including ball valve. Additional pressure drops, e.g. heatmeter with $Q_n 1,5$ of approximately **0,05 bar** and other installations must be included.

11 E-compact instant water heater CEX-U/CEX

11.1 Installation



Installing instructions for the professional

E-compact instant water heater CEX-U



Overview

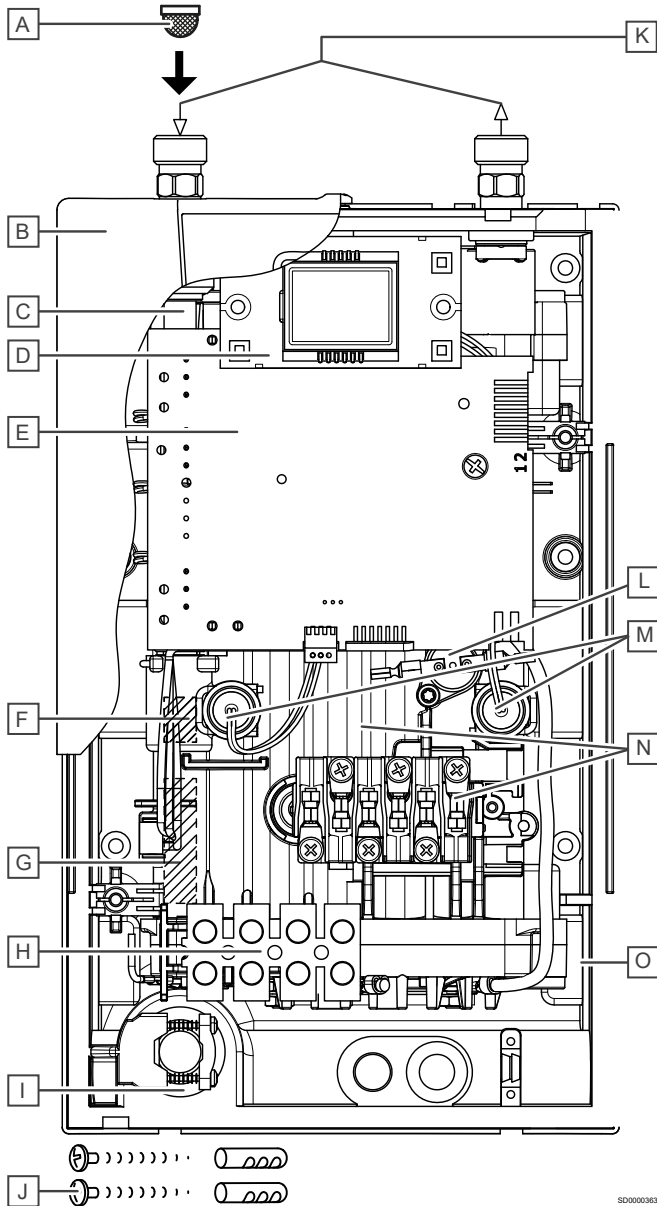

Note

Carefully read the enclosed safety instructions through in full **before** the appliance is installed and put into service and follow them in the further steps!



Item	Description
A	Filter
B	Hood
C	Inlet pipe
D	Control panel
E	Electronics
F	Non-return valve
G	Flow sensor
H	Connecting terminal
I	Grommet
J	Screws and dowels
K	Cold and hot water connection
L	Safety thermal cut-out
M	Temperature sensor set
N	Heating element with SDB
O	Bottom part

Technical specifications

Model	CEX13,5-U ELECTRONIC MPS®		CEX21-U ELECTRONIC MPS®	
Energy efficiency class	A ¹⁾		A ¹⁾	
Rated capacity (Rated current)	11/13,5 kW (16/19,5 A)		18/21 kW (26/30 A)	
Chosen capacity (Chosen current)	11 kW (16 A)	13,5 kW (19,5 A)	18 kW (26 A)	21 kW (30 A)
Electrical connection	3~/PE 380..415 V AC		3~/PE 380..415 V AC	
Min. required cable size	1,5 mm ²	2,5 mm ²	4 mm ²	4 mm ²
Hot water (l/min) max. at $\Delta t = 33$ K	4,8	5,8 ²⁾	7,8 ²⁾	9,1 ²⁾
Rated volume	0,3 l		0,3 l	
Rated pressure	1,0 MPa (10 bar)		1,2 MPa (12 bar)	
Connecting type	pressure resistant/pressureless		pressure resistant/pressureless	
Heating system	Bare wire heating system IES ®		Bare wire heating system IES ®	
Required spec. water resistance @ 15 °C	$\geq 1000 \Omega\text{cm}$		$\geq 1000 \Omega\text{cm}$	
Spec. electrical conductivity	$\leq 100 \text{ mS/m}$		$\leq 100 \text{ mS/m}$	
Inlet temperature	$\leq 60 \text{ °C}$		$\leq 60 \text{ °C}$	
Flow rate to switch on – max. flow rate	2,0-5,0 l/min ³⁾		2,5-8,0 l/min ³⁾	
Pressure loss	0,2 bar at 2,5 l/min 1,3 bar at 9,0 l/min ⁴⁾		0,2 bar at 2,5 l/min 1,3 bar at 9,0 l/min ⁴⁾	
Temperature choice	20-60 °C		20-60 °C	
Water connection	G 3/8"		G 3/8"	
Weight (when filled with water)	2,7 kg		2,7 kg	
VDE class of protection	I		I	
Type of protection / safety				

1) The declaration complies with the EU regulation No 812/2013.

2) Mixed water.

3) Flow rate limited to achieve optimum temperature rise.

4) Without flow regulator.

Dimensions

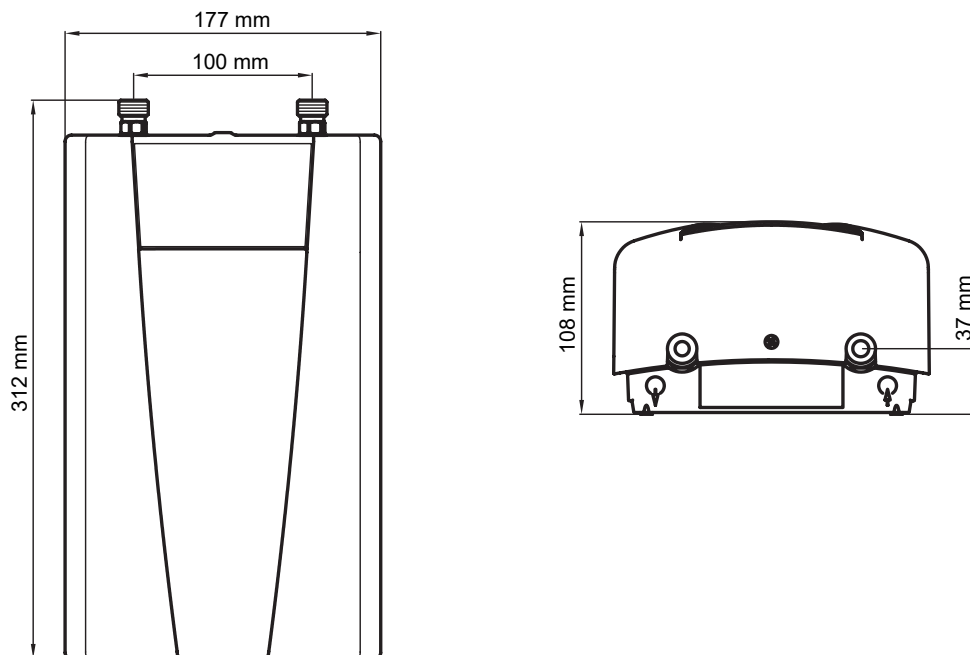

ZD0000109

Installation



The following regulations must be observed:

- e.g. VDE 0100
- EN 806
- Installation must comply with all statutory regulations, as well as those of the local electricity and water supply companies.

Installation site

- Appliance must only be installed in frost-free rooms. Never expose appliance to frost.
- The Appliance is designed for undersink installation and has to be installed with water connectors upward.
- The appliance complies with protection type IP 24.
- In order to avoid thermal losses, the distance between the instantaneous water heater and the tapping point should be as small as possible.
- For maintenance work, a shut-off valve should be installed in the supply line. The appliance must be accessible for maintenance work.
- Copper or steel connecting pipes may be used. Plastic pipes may only be used if they conform to DIN 16893, Series 2. The hot water pipes must be thermally insulated.
- The water pipes must not exert any mechanical force on the water connections of the instantaneous water heater during installation and operation. If this cannot be guaranteed due to the installation conditions, we recommend the use of flexible connections.
- The specific resistance of the water must be at least 1300 Ωcm at 15 °C. The specific resistance can be asked for with your water distribution company.

Electrical connection

	Warning! Risk of electric shock if touching the components! The unit operates with a 400 V AC (electric heater), 230 V AC (control unit) voltage.
	Warning! Required work must be performed by a qualified installer in accordance with local regulations. This includes electrical connections and installations, set up for operation and maintenance.
	Warning! Upon system power supply: 400 V AC (electric heater), 230 V AC (control unit). In case of emergency, immediately disconnect the power.

Item	Description
A	Electronic circuitry
B	Heating element
C	Safety pressure cut-out
D	Connecting terminal
E	Safety thermal cut-out

Only by a specialist!

Please observe:

- e.g. VDE 0100
- The installation must comply with current IEC and national local regulations or any particular regulations, specified by the local electricity supply company
- The rating plate and technical specifications
- The appliance must be earthed!

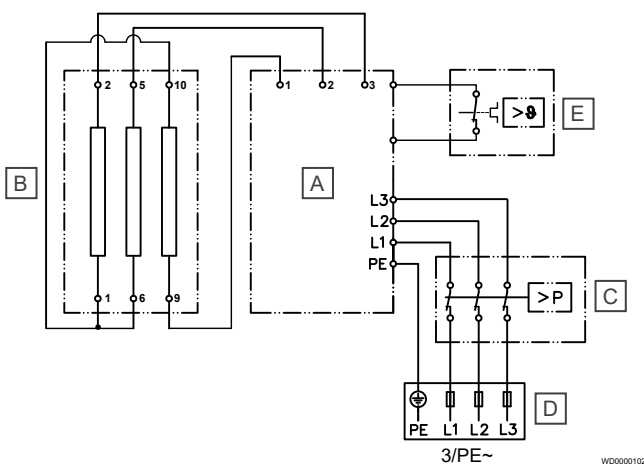

Structural prerequisites

- The appliance must be installed via a permanent connection. Heater must be earthed! Maximum cable cross section: 6 mm².
- The electric wiring should not be injured. After mounting, the wiring must not be direct accessible.
- An all-pole disconnecting device (e.g. via fuses) with a contact opening width of at least 3 mm per pole should be provided at the installation end.
- To protect the appliance, a fuse element must be fitted with a tripping current commensurate with the nominal current of the appliance.

Load shedding relay/box

If further three-phase appliances are connected, we recommend the use of CLAGE's prepared load shedding box (art. no. 82260). Alternatively, a load shedding relay (CLAGE art. no. 82250) can be connected to phase conductor L2. A special operating mode must be selected on the appliance for this purpose.

LCD	Description
0	Operation without load shedding, manufacturer's setting
1	Operation with normal load shedding relay
2	Operation with sensitive load shedding relay

To change the operating mode, press the three keys ①, ②, ▲ and ▼ simultaneously and wait until the desired mode (0, 1 or 2) is shown on the display, then release the keys. Operating mode 1 must be selected first, thus to check the correct operation of the load shedding relay at low appliance output (35 degree set point and low waterflow rate). Mode 2 must be selected if the load shedding relay flickers.

Electrical connection



Caution!

Check that the power supply is switched off prior to electrical connection!

Electrical connection with pre-installed power cable

The appliance is to be connected with the pre-installed power cable to a terminal box. If necessary, use one of the three predetermined breaking points for the cable entry (at the right, left or bottom).

Alternative

Electrical installation to a permanent connection

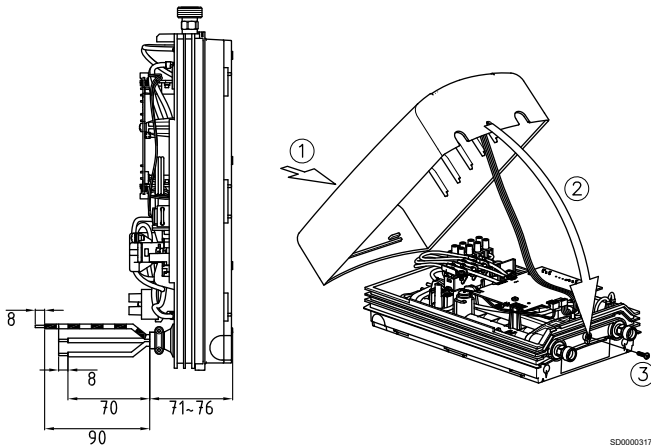

SD0000317

If, in case of particular local circumstances, connecting to a permanent connection is the only possibility, continue as follows.

1. Disassemble the pre-installed power cable.
2. Dismantle off the power cable so that you can insert the cable with the cladding through the water splash protection sleeve up to the cord grip into the appliance.
3. Lead the cable through the water splash protection sleeve into the appliance so that one can securely fix the cladding of the cable with the cord grip. If necessary, use one of the three predetermined breaking points for the cable entry (at the right, left or bottom). The protective sleeve prevents water from entering the appliance alongside the connection line. The protection sleeve has to be used!
4. Mount the cord grip. The cord grip must be used!
5. Strip the cables and plug them in the connecting terminals according to the wiring diagram. The appliance must be earthed.
6. After successful electrical connection, fit the hood of the unit. Make sure not to jam any cables between the appliance hood and the base part of the appliance.

Initial operation



Caution!

Before making the electrical connection, fill the mains and the appliance with water by carefully opening and closing the hot water tap in order to vent completely.

To ensure a maximum flow, remove any existing aerator from the faucet. Flush the warm and cold water pipes each at least for one minute.

After every draining (e.g. after work on the plumbing system or following repairs to the appliance), the heater must be re-vented in this way before starting it up again.

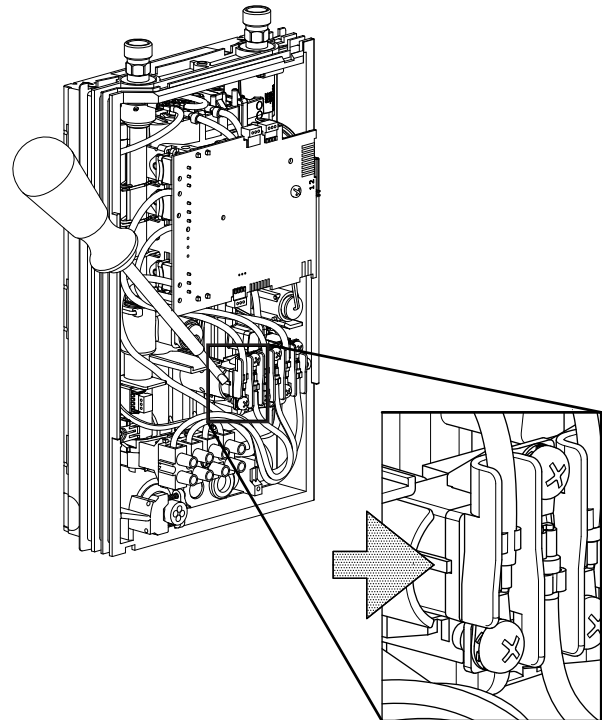

SD0000314

If the water heater cannot be put into operation, the temperature cut-out or the pressure cut-out may have tripped during transport. If necessary, reset the cut-out.

Selection of power rating

Only by authorised specialist, otherwise lapse of guarantee!

Upon first connection of the appliance to the supply voltage, select the maximum power rating. Only after having set the power rating, the heater provides its standard operation mode.

The maximum allowable power rating at installation site depends on the local situation. It is imperative to observe all data shown in the table "Technical specifications", in particular the required cable size and fuse protection for the electrical connection. Moreover, the electrical installation must comply with the statutory regulations of the respective country and those of the local electricity supply company (Germany: DIN VDE 0100).

Multiple Power System:

CEX13,5-U:

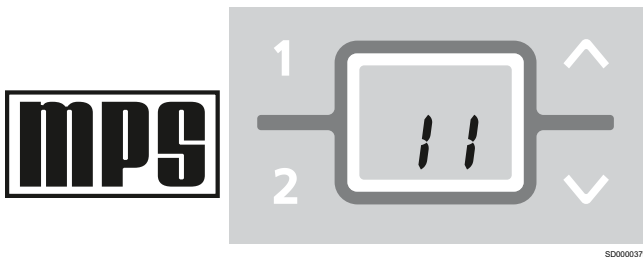

The rated capacity (max. power consumption) is 11 kW/400 V and can be changed internally to 13.5 kW.

1. Switch on the power supply to the appliance. The digital display on the appliance must light up.
2. When switching on the supply voltage for the first time, the value "11" flashes in the display. If not, please carefully read the note "Reinstallation".
3. Select the maximum allowable power rating depending on the local situation via the up \wedge and \vee down arrow keys: 11 or 13 kW.
4. Press key $\textcircled{1}$ to confirm the setting. The appliance starts operating.
5. Mark the set power rating on the rating plate.

Reinstallation

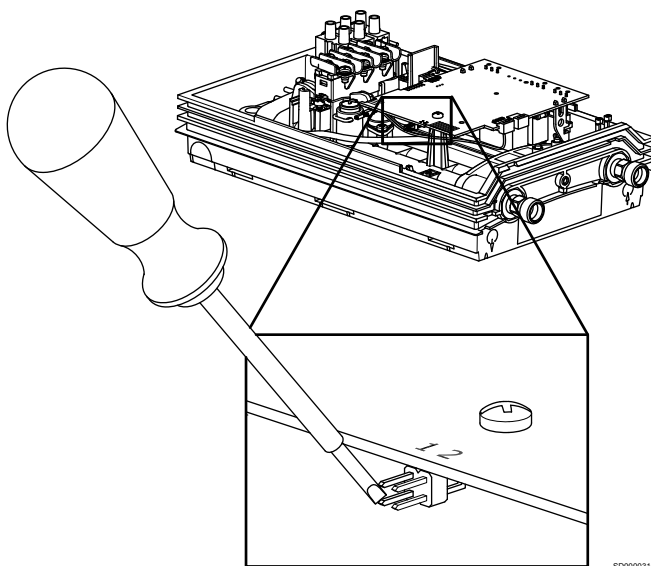

6. Open the hot water tap. Check the function of the appliance.
7. After having set the maximum allowable power rating, the heating element will be activated after approx. 10 - 30 seconds of water flow.
8. Explain the user how the instantaneous water heater works and hand over the operating instructions.
9. Fill in the guarantee registration card and send it to the after-sales service or use the online registration.

CEX21-U:

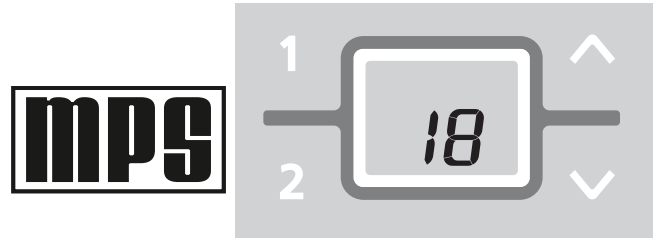

The rated capacity (max. power consumption) is 18 kW/400 V and can be changed internally to 21 kW.

1. Switch on the power supply to the appliance. The digital display on the appliance must light up.
2. When switching on the supply voltage for the first time, the value "18" flashes in the display. If not, please carefully read the note "Reinstallation".
3. Select the maximum allowable power rating depending on the local situation via the up \wedge and \vee down arrow keys: 18 or 21 kW.
4. Press key $\textcircled{1}$ to confirm the setting. The appliance starts operating.
5. Mark the set power rating on the rating plate.
6. Open the hot water tap. Check the function of the appliance.
7. After having set the maximum allowable power rating, the heating element will be activated after approx. 10 seconds of water flow.
8. Explain the user how the instantaneous water heater works and hand over the operating instructions.
9. Fill in the guarantee registration card and send it to the after-sales service or use the online registration.

In case the appliance will be commissioned again under different installation conditions than during its initial operation, it may be necessary to adapt the maximum power rating. A temporary short-circuit of the two pins, e.g. with a screwdriver acc. to EN 60900 (see figure), will reset all heater parameters to works setting and lock the heating.

CEX13,5-U:

Value "11" flashes in the display until the maximum power rating has been selected. This condition will maintain when activating and deactivating the supply voltage.

CEX21-U:

Value "18" flashes in the display until the maximum power rating has been selected. This condition will maintain when activating and deactivating the supply voltage.

Shower application

The water heater's temperature must be limited to 55 °C, if it is connected to a shower. The service menu parameter "Temperature Limit" ("tL") must be set to a value less or equal 55 °C, in consultation with the customer and the lock level must be activated.

Lock level

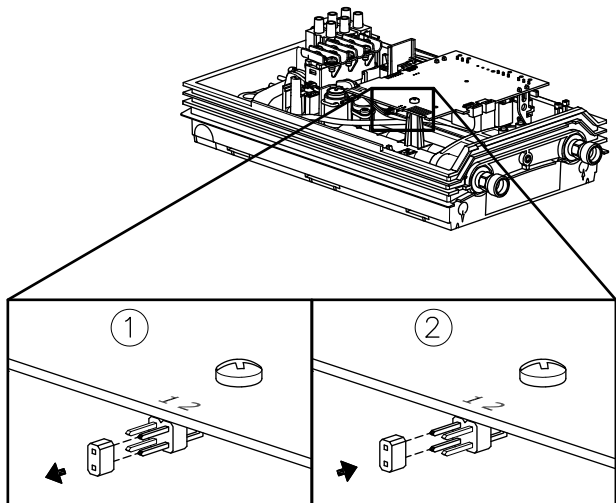

When the device is operated with preheated water, it must be ensured that this temperature is limited to 55 °C as well.

The operating mode of the appliance can be restricted. The service menu can be used to configure the appliance.

Activation of the lock level

1. Set required lock level in the service menu (refer to chapter "Service menu" in this installing instructions).
2. Disconnect the appliance from the power supply (e.g. by switching off the fuses).
3. Move the jumper on the power electronics from pin 2 to pin 1 (see figure).
4. Put the appliance into operation again.

Deactivation of the lock level

1. Disconnect the appliance from the power supply (e.g. by switching off the fuses).
2. Move jumper from pin 1 to pin 2.
3. Put the appliance into operation again.

Service menu

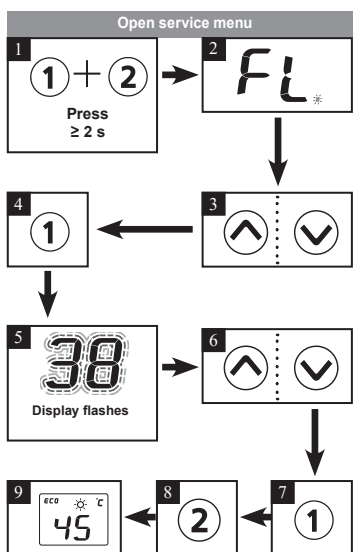

The service menu offers an overview of system parameters and is used for diagnostics.

Press key ① and key ② simultaneously for at least 2 seconds to call up the service menu, the display confirms by "FL" and by a flashing point. Using the arrow keys \wedge and \vee , you can switch between the individual menu items.

Press key ① to see the value of the currently selected menu. The value flashes in the display. (The values of some menus can be switched over by using the arrow keys \wedge and \vee .) You will get back to the drop-down-menu when pressing key ① again. With key ② you will get back to the standard display (nominal value). After two minutes without any key stroke the system automatically switches back to the standard display.

Menu item order of "Service menu":

	<i>FL</i>	Flow
	<i>Po</i>	Power
	<i>t1</i>	Temp in
	<i>t2</i>	Temp out
⌵	<i>CR</i>	Control value
	<i>PL</i>	Power limit
	<i>Er</i>	Diagnostics
	<i>LL</i>	Lock level
⌶	<i>nr</i>	Software version
	<i>Ch</i>	Radio channel
	<i>rS</i>	Received strength
	<i>tL</i>	Temperature limit
	<i>IL</i>	Signal

Individual menu items as follows:

"FL": **Flow**
Indication of current flow rate given in l/min.

"Po": **Power**
Indication of current power consumption (kW).

"t1": **Temp in**
Indication of inlet temperature (°C).

“t2“: Temp out

Indication of outlet temperature (°C).

“CA“: Control value

Indication of calibration value of the controlsystem. Regular range: 40 - 60.

“PL“: Power limit

Indication of the current maximum power rating (kW) of the appliance.

“Er“: Diagnostics

Indication of the last ten diagnostic messages.

The error code is indicated by the first displayed value after pressing key ① (refer to “Abstract for Trouble-Shooting & Diagnostics” in the hood). By using the arrow keys \wedge and \vee the last 10 error codes are displayed chronologically. Thereby the display indicates in turns the error numbers from “0” to “9” and the corresponding error. The last error will be recorded at position “0” and the former ones each shifted 1 position backwards.

“LL“: Lock level

The operating mode of the appliance can be restricted.

Setting Options:

“0”	no restriction (factory setting)
“1”	factory reset via key (countdown) not possible, parameters can be seen, but not be modified in setup menu
“2”	same as “1”, additionally the setup menu cannot be opened
“3”	same as “2” additionally nominal valuememory 1 and 2 not changeable
“4”	same as “3”, additionally nominal valuenot changeable

Environment and recycling



This product was manufactured climate neutrally according to Scope 1 + 2. We recommend the purchase of 100% greenelectricity to make the operation climate neutral as well.

Disposal of transport and packaging material:

For smooth transport yourproduct is carefully packed. The disposalof the transport material is carried out by the specialist tradesman or the specialist trade. Separate the sales packaging according to materials separated accordingto materials via one of the dual systems in Germany.

Disposal of old products:

Your productwas manufactured from high-quality, reusable materials and components. Products marked with the crossed-out wheeled bin

**Note**

When the setting 1, 2, 3 or 4 was chosen, the system parameters can no longer be modified in the service menu.

In order to modify these system parameters, it is necessary to remove the jumper on the power electronics, as specified in the chapter “Deactivation of the lock level”.

“nr“: Software version

Information about installed software version.

“Ch“: Radio channel

(with wireless module only)

Information about the current radio channel of the water heater and its remote control.

“rS“: Received strength

(with wireless module only)

Information about the current signal quality of the remote control as percentage. Depending on the distance between remote control and water heater the value varies between 10% and 100%.

“tL“: Temperature limit

The maximum setable temperature can be reduced to any value within the temperature limit.

The Lock Level must be activated by placing the jumper to enable the limitation.

“IIC“: Signal

Information about the quality of the radio contact when a diagnostic display is connected.

symbol must be disposed of separately from household waste at the end of their service life. Therefore, take this product to us as the manufacturer or to one of the municipal collection points that recycle used electronic devices. This proper disposal serves to protect the environment and prevents possible harmful effects on humans and the environment that could result from improper handling of the products at the end of their service life. For more detailed information on disposal, please contact your nearest collection point or recycling centre or your local council.

Business customers:

If you wish to discard equipment, please contact your dealer or supplier for further information.

For disposal outside Germany, please also observe the local regulations and laws.

Kurzanleitung Quick reference guide

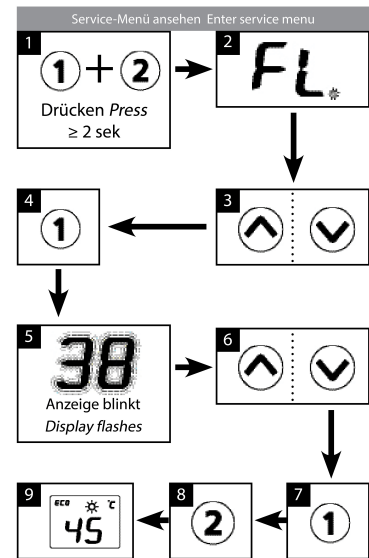
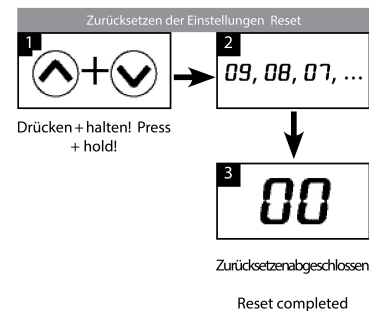
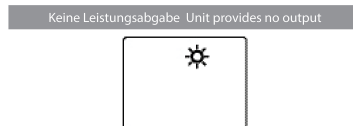
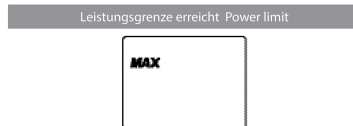
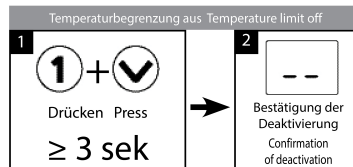
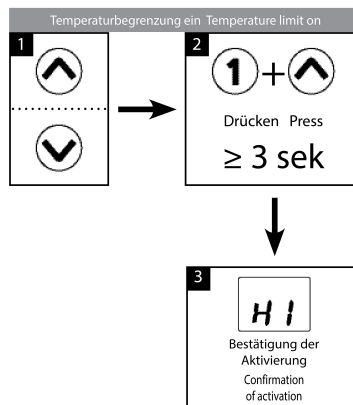
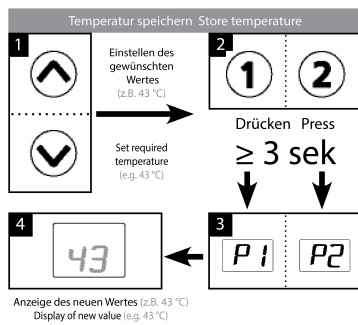
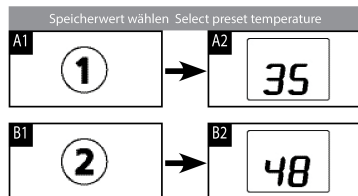
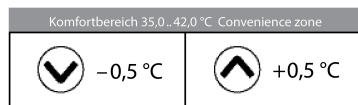
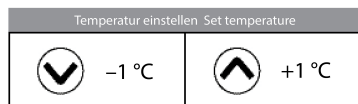
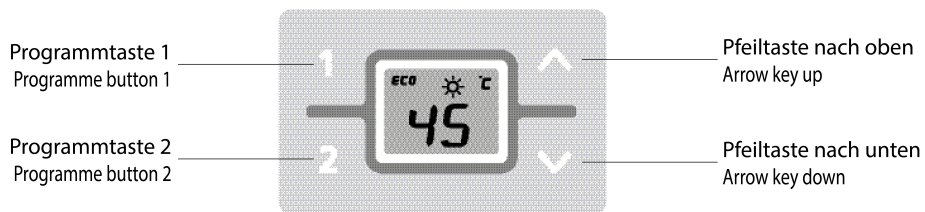

Technische Änderungen, Änderungen der Ausführung und Irrtum vorbehalten. Subject to technical changes, design changes and errors. Sauf modifications techniques, changements constructifs et erreur ou omission. Technische wijzigingen, wijzigingen van de uitvoering en misverstanden voorbehouden. Reserva-se o direito a alterações técnicas, falhas de impressão e erros. Reservado el derecho a realizar modificaciones técnicas, cambios en el diseño y a corregir los errores. Zastrzega się zmiany techniczne, zmiany w wykonaniu i pomyłki. Med reservation för tekniska ändringar, ändringar i utförande samt felinformation. Technické změny, změny v provedení a omyl vyhrazeny. Technické zmeny, zmeny vyhotovenia a chyby vyhradené. 9120-25652 06.23



11.2 Operation



Operating instructions for the user

*E-compact instant water heater
CEX-U / CEX*



Description of the appliance

Note

Carefully read the enclosed safety instructions through in full **before** using the appliance and follow them during use!

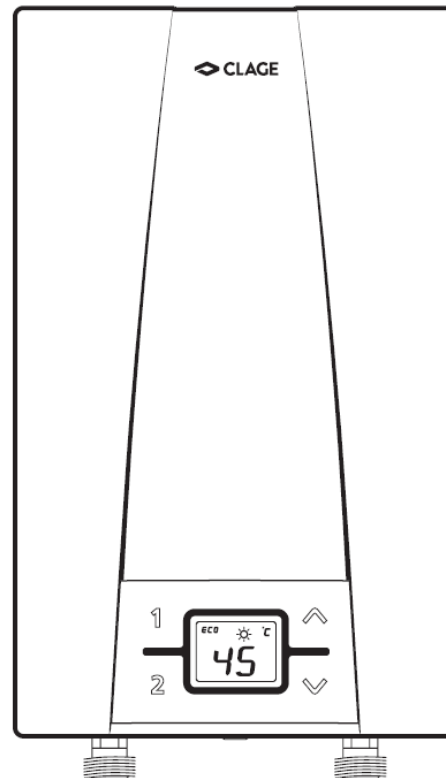
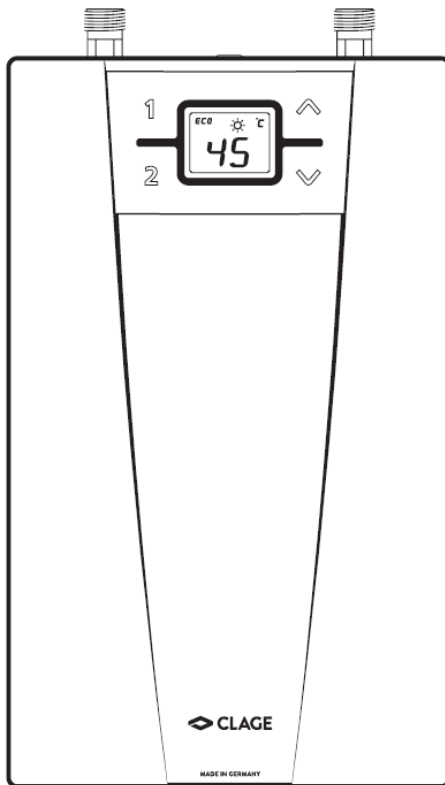

SD0000364

The instantaneous water heater CEX-U/CEX is an electronically controlled, pressure-resistant water heater for a decentralised hot water supply to one or more outlets.

Its electronic control regulates the heating power consumption depending on the selected outlet temperature, the respective inlet

temperature and the flow rate, thus reaching the set temperature exactly to the degree and keeping it constant in case of pressure fluctuations. The required outlet temperature can be entered on a keypad and can be read off the digital display.

How to use

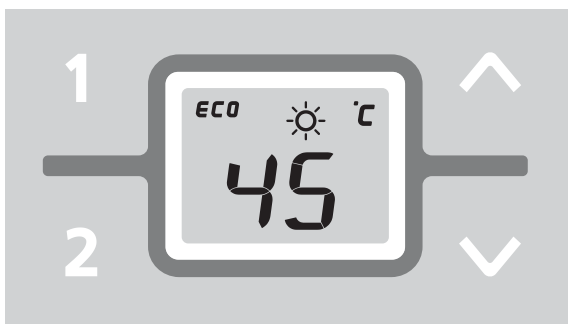

SD0000365

As soon as you open the hot water tap, the instantaneous water heater switches on automatically. When the tap is closed, the appliance automatically switches off.

Temperature setting

- Note**
If temperature is set below 20 °C with arrow key \downarrow the display shows "--" and the appliance switches off the heating function.
- Note**
If the water heater supplies a shower, the maximum temperature was reduced during initial operation. This limitation cannot be exceeded.

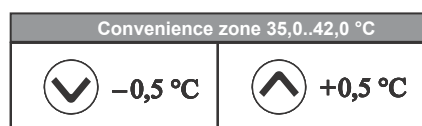
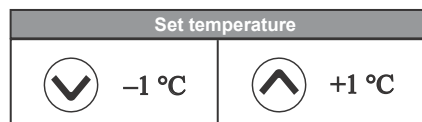

SD0000366

You can set the required temperature gradually to a lower or higher value with the arrow keys \wedge and \vee .

The temperature changes by 1 °C, in the convenience zone between 35 °C and 42 °C by 0.5 °C, if key is pressed shortly one time. Pressing a key for a longer time changes the temperature continuously.

Programme buttons

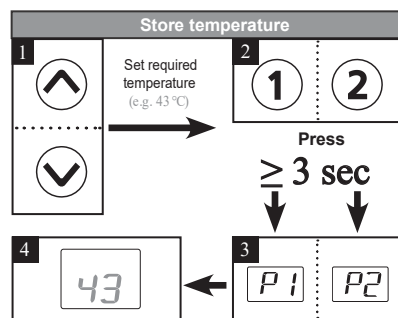
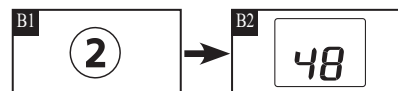
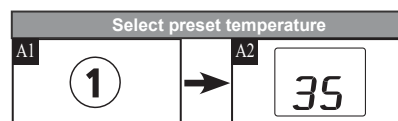

Display of new value (e.g. 43 °C)

SD0000378

The two programme buttons allow to quickly select the preset temperature. When pressing a programme key, the preset temperature is selected and displayed. The factory setting for programme $\textcircled{1}$ is 35 °C and for programme $\textcircled{2}$ it is 48 °C. You can assign your own settings for the programme keys:

- Prolonged pressing of the programme key stores the previously selected temperature. The display changes from "P1" or "P2" to the newly stored temperature value. This newly set temperature is now available to you each time you press the corresponding program key..

Temperature limitation

- Note**
By activation of the temperature limit also the programme keys are affected. Therefore, the fixed values of the programme keys must be checked after changing the temperature limitation.

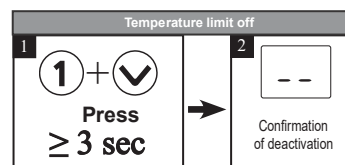
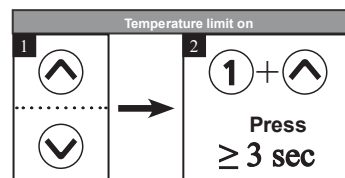

SD0000377

This instantaneous water heater is equipped with an optional temperature limiting function. This scalding protection is deactivated in the factory setting.

- Switch on:** Select the limit temperature, then press $\textcircled{1}$ and \wedge simultaneously for atleast 3 sec. The display briefly confirms the activation by "HI".
- Switch off:** Press program key $\textcircled{1}$ and \vee simultaneously for at least 3 sec. The display briefly confirms the deactivation by "--".

Reset to factory setting

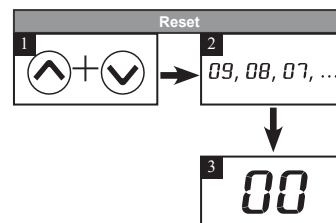

SD0000376

All factory settings can be recalled:

- Press \wedge and \vee simultaneously. The display now counts backwards from "10" to "00" in second intervals. The appliance is reset at value "00" - if you stop pressing the keys earlier, you will cancel the process.

How to save energy



SD0000375

Set the exact temperature you need on the appliance and open the hot water tap. Once you feel that the water is too hot, do not add any cold water and, instead, enter a lower temperature on the appliance. If you were to add cold water, the water already heated would cool down again and valuable energy would be wasted. Moreover, the cold water added in the tap is not covered by the control range of the electronic circuitry, with the result that temperature constancy is no longer guaranteed.

ECO mode

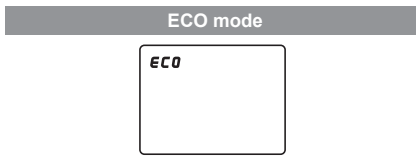

SD0000370

The symbol **ECO** shows that the appliance works in an energy saving mode (i.e. the momentary energy consumption is subject to the selected temperature and to the flowrate in the energy saving mode).

Power limit

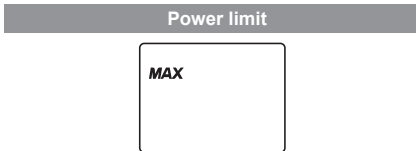

SD0000369

If the full output of the instantaneous water heater does not suffice to heat the tapped quantity of water, this will be indicated by **MAX** on the LCD (e.g. in winter time, when opening several taps at once). When you reduce the hot water flow rate, **MAX** stops lighting because the output of the appliance is sufficient to reach the set temperature again.

Top-up heating

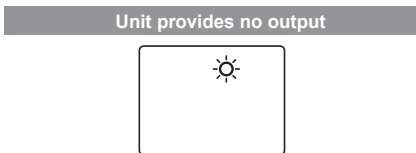

SD0000368

When operating with preheated water (e.g. with solar systems), ensure that the maximum inlet temperature is not exceeded.

If the inlet temperature exceeds the setpoint, the icon on the digital display indicates ☀ that the heating power is switched off.

Trouble-shooting and service



Caution!

Repairs must only be carried out by authorised professionals.

If a fault in your appliance cannot be rectified with the aid of this table, please contact the service organisation of your importer or the Central Customer Service Department. Please have the details of the type plate at hand.

Venting after maintenance work



Caution!

This instantaneous water heater features an automatic air bubble protection to prevent it from inadvertently running dry. Nevertheless, the appliance must be vented before using it for the first time. Each time the appliance is emptied (e.g. after work on the plumbing system, if there is a risk of frost or following repair work), the appliance must be re-vented before it is used again.

- Disconnect the instantaneous water heater from the mains (e.g. via deactivating the fuses).
- Unscrew the jet regulator on the outlet fitting and open the cold water tap valve to rinse out the water pipe and avoid contaminating the appliance or the jet regulator.
- Open and close the hot water tap until no more air emerges from the pipe and all air has been eliminated from the water heater.
- Only then should you re-connect the power supply again (e.g. via activating the fuses) to the instantaneous water heater and screw the jet regulator back in.
- The appliance activates the heater after approx. 10 seconds of continuous waterflow.

Cleaning and maintenance

- Plastic surfaces and fittings should only be wiped with a damp cloth. Do not use abrasive or chlorine-based cleaning agents or solvents.
- For a good water supply, the outlet fittings (e.g. jet regulators and shower heads) should be unscrewed and cleaned at regular intervals. Every three years, the electrical and plumbing components should be inspected by an authorised professional in order to ensure proper functioning and operational safety at all times.

This instantaneous water heater was manufactured conscientiously and checked several times before delivery. Should malfunctions nevertheless occur, it is usually only due to a bagatelle. First attempt to switch the house fuses off and on again in order to reset the electronics. Next, try to remedy the problem with reference to the following table. In doing so, you will avoid unnecessary expense of customer service assistance.

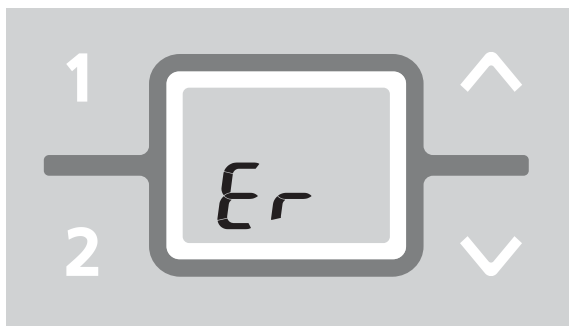

SD0000367

Problem	Cause	Solution
Water stays cold, digital display does not light up	Master fuse tripped Safety pressure cut-out tripped	Renew or activate fuse Contact customer service

Problem	Cause	Solution
Water stays cold, digital display does light up	Safety thermal cut-out tripped	Contact customer service
Display flashes error message "Er"	Pipe clamps too tight	Check the pipe clamps
	Control system has switched off	Switch fuse off and on. If "Er" still flashes contact customer service
Flow rate of hot water too weak	Outlet fitting dirty or calcified	Clean shower head, jet regulator or sieves
	Fine filter dirty or calcified	Let clean fine filter by a specialist
Selected temperature is not reached, "MAX" lights	Water flow rate too high	Reduce water flow rate at the tap
Selected temperature is not reached, "MAX" does not light	Cold water has been added via the tap	Tap hot water only; set temperature for use
Symbol "sun" lights up	Inlet temperature exceeding nominal temperature	Reduce inlet temperature
Appliance heats, the display does not light	Display plug not properly connected	Let fix correct position of display plug by customer service

If the connection cable is damaged, it must be replaced with an original spare cable from the manufacturer by an authorised technician in order to avoid any hazards.

If you cannot rectify the fault with the aid of the troubleshooting table, please contact customer service.

CLAGE GmbH

After-Sales Service
 Pirolweg 4
 21337 Lüneburg
 Germany

Phone: +49 4131 8901-400

Email: service@clage.de

Uponor

Uponor GmbH

Industriestraße 56,
D-97437 Hassfurt, Germany

1144440 v1_06_2024_EN
Production: Uponor/SKA

Uponor reserves the right to change the product portfolio and the related documentation without prior notification, in line with its policy of continuous improvement and development.



www.uponor.com